



# 微耕机机组零部件图册

PART CATALOGUE



**1WG3.4-90FQ-Z**

版本号 **VERSION No.:** 2011-01

本零件目录是根据2010年08月所能得到的最新资料编制而成的。

This parts catalogue was prepared based on the latest information available as of August 2010.

请注意2010年08月以后本零部件目录的修订通知。

See the parts catalogue news for any revision that is made after August 2010.

当订购零件时，一定要明确指出其零件编号。

Always specify the part number when ordering a part.

注意本零件目录所给出的图形可能与实际零件外形有所不同。

Note that the illustrations can differ from the actual parts in shape.

当需要对零部件目录的内容进行更改或增加时，本公司将在适当的时间出版修订版，为保证在任何时候都可以使用到最新版本的零部件目录，建议拥有最新的修订版本。如果要检查修订版本是否已经发行，请直接与LONCIN联系。

When modifications or additions to this parts catalogue are made, a revised edition will be issued at an appropriate time. We recommend obtaining such revisions in order to keep your parts catalogue up-to-date at all times. To check whether a part catalogue revision has been issued, please contact your LONCIN distributor.

示例 (Example)

序号 No.	零部件件号 Part No.	零部件名称	Description	数量 (Reqd. QTY.)
1	191910004-0001	减速箱体	Gear Box	1





序号 No.	零 部 件 件 号 Part No.	零 部 件 件 号	Description	数 量 Reqd.QTY.
1	380610177-0001	销轴 6X41	Pin 6X41	1
2	380590010-0003	开口销 1.6X20	Pin 1.6X20	2
3	192430016-0001	换档臂	Shift Arm	1
4	380822344-0001	衬套 $\phi 16X\phi 20X36$	Bush $\phi 16X\phi 20X36$	1
5	380840789-0001	密封圈 $\phi 11.2X\phi 2.65$	Airproof Circle	6
6	195300003-0001	换档凸轮	Shift Cam	1
7	192370011-0001	换档拨块	Shift Dial	1
8	380822418-0001	衬套 $\phi 16X\phi 20X32$	Bush $\phi 16X\phi 20X32$	3
9	110690053-0001	机油尺组合	Dipstick	1
10	380630005-0001	轴承 6204	Bear 6204 GB/T276	1
11	380840791-0001	密封圈 $\phi 45X\phi 1.8$	Airproof Circle	1
12	195190003-0001	油封座	Seal Seat	1
13	380840788-0001	密封圈 $\phi 17X\phi 1.8$	Airproof Circle	2
14	380650349-0001	油封B25X40X7	Seal B25X40X7	1
15	380822345-0001	衬套 $\phi 20X\phi 25.2X12.5$	Bush $\phi 20X\phi 25.2X12.5$	1
16	380490017-0001	锁紧垫圈GB858 20	Stop Washer	2
17	380810052-0001	圆螺母GB/T812 M20X1.5	Nut GB/T812 M20X1.5	2
18	380620088-0001	键GB/T1096 6X20	Key GB/T1096 6X20	1
19	192660002-0001	护套	Jacket	1
20	380450039-0003	平垫圈GB/T5287 8	Washer GB/T5287 8	2
21	380460001-0006	弹性垫圈GB/T93 8	Washer GB/T93 8	2
22	380070045-0005	六角头螺栓M8X25	Bolt M8X25	2
23	141140004-0001	防尘帽	Dustproof Cap	1
24	380450004-0003	平垫圈GB/T97.1 6	Washer GB/T97.1 6	2
25	380460003-0003	弹性垫圈GB/T93 6	Washer GB/T93 6	4
26	380190008-0005	内六角螺钉M6X20	Bolt M6X20	4
27	380340005-0005	六角螺母 M8	Nut M8	2
28	193910016-0001	拉索挂耳	Pothook	2
29	380600156-0001	定位销GB/T119.2 5X10	Pin GB/T119.2 5X10	1
30	380450826-0001	平垫圈 $\phi 10.5X\phi 22X4$	Washer $\phi 10.5X\phi 22X4$	1
31	380460002-0006	弹性垫圈GB/T93 10	Washer GB/T93 10	1
32	380070123-0004	六角头螺栓M10X25	Bolt M10X25	1

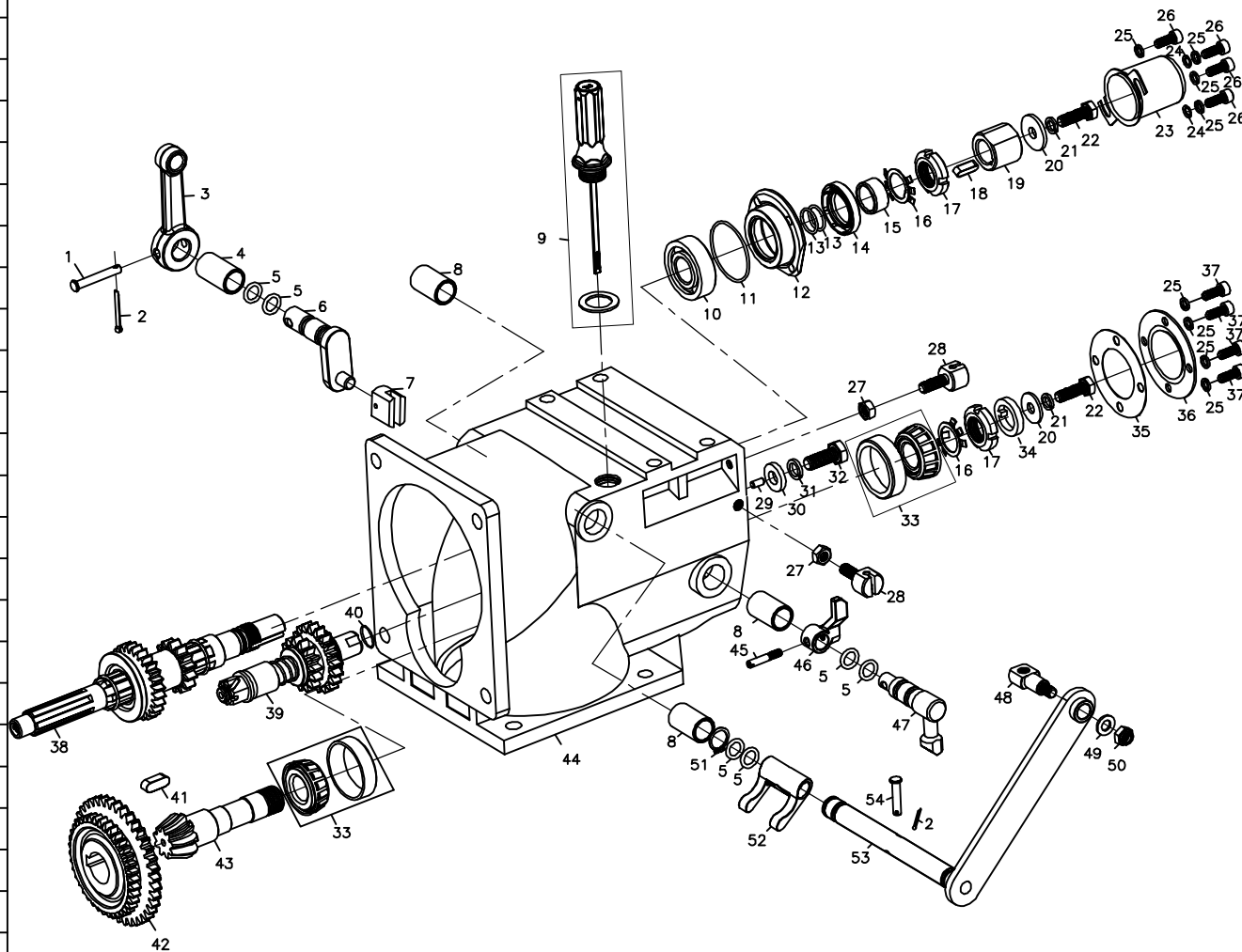















隆鑫通用动力股份有限公司

Loncin motor co., Ltd.

详细地址：重庆市九龙坡区九龙工业园区华龙大道99号

Add:No.99Hualong Road, Jiulongpo District, Chongqing, China

Tel:86 23 8980 5678/86 23 8980 8505

Fax:86 23 8906 7566

Email:service@loncinengine.com

Website:www.loncinengine.com

**PRINTED IN CHINA**