

LONCIN 隆鑫

General power products

600 Mini Tiller

Tiller Owner s Manual

1WG3.6-60FQ-D



www.loncinengine.com

Loncin motor co.,ltd.

Foreword

Thank you for purchasing our company's mini tiller

With a small size, a light weight, multiple functions, high rotary tilling efficiency, ability to work on mountains, in waters, to cross ridges of fields and ditches, and easy transport and operation of turning around, this model of tiller is especially suitable for work in mountain areas, hilly areas, arid fields, irrigated fields, orchards, gardens, arch-roofed sheds, etc.

Warning! Please pay special attention to the following information:

Please read carefully this operation and maintenance manual before operation and strictly comply with the manual while operating. If you operate in compliance with the manual, the tiller designed by our company can work safely and reliably without damage to equipment and personal injury. Should you not operate in compliance with the manual, there may occur severe damage or injury to your equipment or your body.

Note! Should there be any problem with the machine, or should you have any doubt about it, please contact our company's local sales agent.

Contents

Chapter I Safety warnings	1
Chapter II Safety symbols	5
Chapter III Brief introduction of tiller	7
i. Major technical parameters	7
ii. Names of major parts and components of tiller	8
Chapter IV Operation method of the tiller	9
i. Routine check	9
ii. Status adjustment of the tiller	17
Chapter V Running	18
i. Steps to start it	18
ii. How to stop the engine	22
Chapter VI Maintenance of gasoline engine	24
Chapter VII Maintenance of tiller	30
Chapter VIII Trouble shooting	34

Chapter I Safety warnings

1. Training

a) Carefully read the operation manual. Get fully familiar with the correct method of operation of this machine and its mechanisms. Understand how to stop it and how to quickly disengage the operation mechanism.

b) No child is allowed to use the machine! No adult is allowed to use the machine before carefully reading the manual!

c) Ensure no other persons or things with potential safety risk, especially children and pets, are inside the working area!

2. Preparation

a) Thoroughly check the area for the machine to work in, and remove all sundries.

b) Before starting the engine, put shift gear in neutral position!

c) Don't operate the machine without the proper clothing. If the working area has a slippery ground, wear a pair of anti-skid shoes to improve your standing stability.

d) Take care when treating fuel, which is inflammable! Pay attention to the following rules:

1) Use an appropriate container to hold the fuel.

2) When the engine is running or is hot, never try to add fuel into it!

3) Take extra care when fueling the engine outdoors; never try to fuel the engine indoors!

4) Before starting, tighten the fuel tank cap and wipe off any fuel spilled out!

e) Never try to make any adjustment when the engine is running!

f) For any operation or work on the machine, for example, preparation and maintenance of the machine, wearing a pair of safety glasses is necessary.

3. Operation

a) When starting the engine, the shift lever shall stay in the neutral position. The operator's hands and feet are not allowed to approach revolving parts or to be under such parts.

b) When operating the machine on (or while crossing) a cobbled road, sidewalk, or highway, stay alert to the traffic conditions to notice any potential traffic risk! Never use the machine to carry any passenger!

c) If the machine bumps against any foreign thing, please shut off the engine immediately, and thoroughly check whether the tiller is damaged, if so, repair it before restarting and operating it.

d) Always pay attention to the surrounding conditions to avoid slipping down, or dropping.

e) If the machine shows any abnormal vibration, shut off the engine without any delay! Check to find the reason, it's important because abnormal vibration normally is harbinger of

fault.

f) Before leaving the operating position to repair, adjust, check or remove of things jammed between blades, always remember to shut off the engine first!

g) If the machine is to be left uncared by the operator, all necessary preventive measures, such as disengaging power output shaft, lowering of accessory devices, shift to neutral position of gear shift lever, and shutting off the engine shall be taken first!

h) Before cleaning, repair or checking the machine, the operator must shut off the engine and ensure all moving parts are in a stationary state!

i) Engine's emission is hazardous, so never try to run it indoors!

j) Never operate the tiller without proper protection equipment, guard or other protection devices in place!

k) When the machine is running, always keep it away from children and pets!

l) Never overload the machine with a big tilling depth and a high speed!

m) The machine is not allowed to run at a high speed on a slippery road. Watch back to take care when driving backward!

n) Never allow any looker-on to approach a running machine!

o) Only the accessory devices and equipment (like the counter weight) allowed by the manufacturer of the tiller may be used

p) Never try to operate the tiller when the view is limited or lighting conditions are poor!

q) Take care when tilling a hard field, because the blades may hook into the ground, hence pushing the tiller forward. If such a result does occur, just let free the handle and don't try to control the machine!

r) Never operate the tiller on an abrupt slope!

s) Take care not to let the machine turn over when it is ascending or descending a slope!

4. Repair, maintenance and storage

a) Keep the machine, accessory devices and equipment, including the battery, in a safe working condition. Whenever possible, detach the battery before storage to prevent freezing, and charge it to some extent when it is necessary to do so.

b) Check whether bolts under shear stress, mounting bolts of engine and other bolts are tightened properly at a fixed interval, so as to ensure the machine can work safely.

c) The machine shall be stored indoors and away from flames, and cool the engine before storing it.

d) If the tiller is to be stored for a long time, the manual shall always be kept as an important material.

e) Don't repair the machine at will unless you have the proper tools and the manual to instruct disassembling, assembling and repairing of the machine.

Chapter II Safety symbols

The following symbols are to remind you that if you don't pay attention, you might be severely injured. Please carefully read the symbols in the manual and notices about safety.

If these symbols peel off or are illegible, please contact the distributor to replace such symbols.

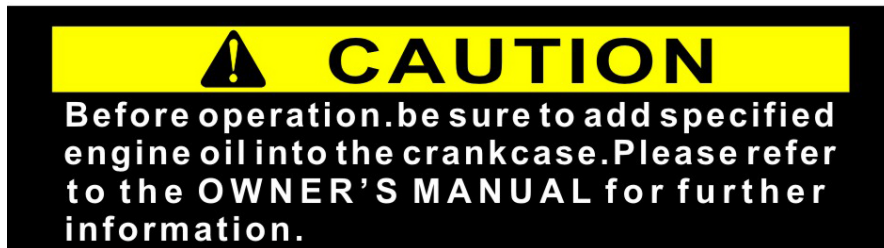

Figure 2-1

Figure 2-1 to be stuck on engine fuel tank

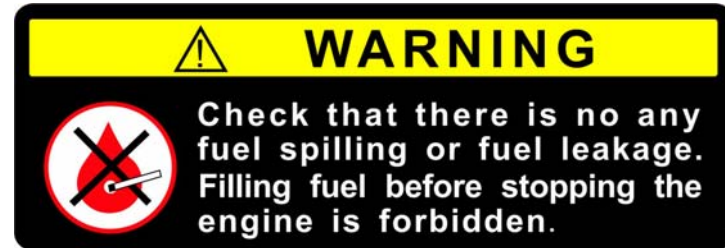

Figure 2-2

Figure 2-2 to be stuck on engine fuel tank

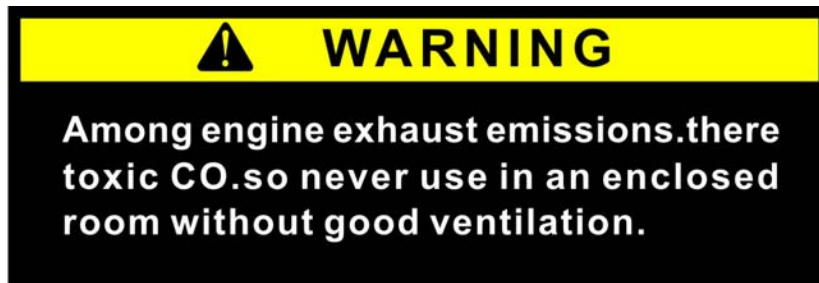

Figure 2-3

Figure 2-3 to be stuck on engine fuel tank

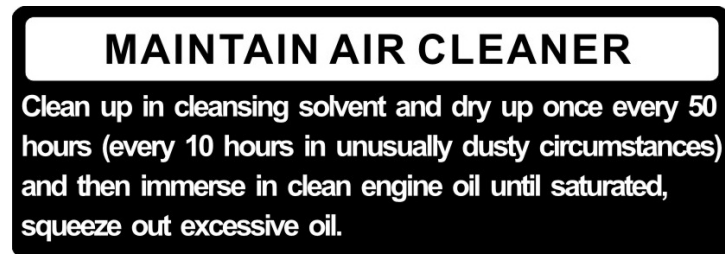

Figure 2-4

Figure 2-4 to be stuck on engine air filter

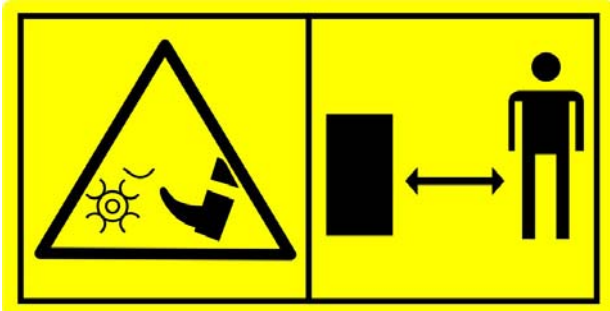

Figure 2-5

Figure 2-5 to be stuck on fender



Figure 2-6

Figure 2-6 to be stuck on belt guard



Figure 2-7

Figure 2-7 to be stuck on fender

Chapter III Brief introduction of tiller

This product is made in compliance with JB/T10266.1-2001 Specification of Handheld Tillers, JB/T10266.2-2001 Testing Method for Hand held Tillers, GB/T5608.3-1995 Testing Method of Rotary Tillers, GB10395.10-2006 Tractors and Machinery for Agriculture and Forestry-Technical Means for Ensuring Safety and DB50/210-2005 Technical Means for Ensuring Safe Operation of Handheld Tillers.

i. Major technical parameters

Nominal power	3.6 kW
Nominal speed	3600 r/min
Starting	Recoil start
Net weight/ gross weight	60/68 kg
Tilling width	55~95 cm
Tilling depth	≥10 cm
Working speed	0.1~0.3 m/s
Transmission	With belt and chain wheel
Rotate speed	120 r/min

ii. Names of major parts and components of tiller

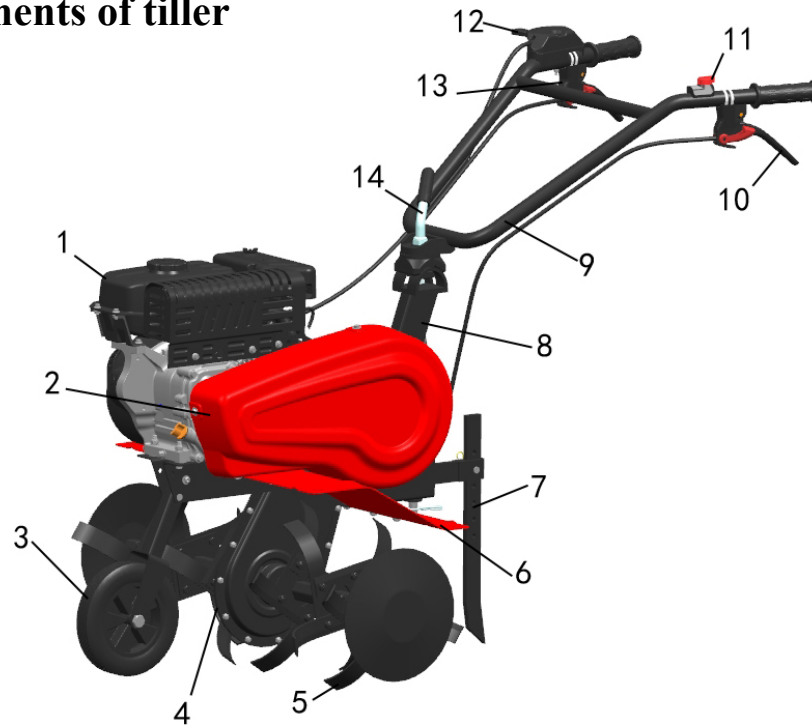

Figure 1

- | | | |
|----------------------------|--------------------------|---------------------------------|
| 1. Gasoline engine | 2. Belt guard | 3. Front wheel assembly |
| 4. Reduction box | 5. Tilling blade | 6. Fender |
| 7. Damping lever | 8. Bracket | 9. Handle pipe assembly |
| 10. Clutch handle, forward | 11. Extinguishing switch | 12. Accelerator valve regulator |
| 13. Clutch handle, reverse | 14. Lifting part | |

Chapter IV Operation method of the tiller

Before each tiller leaves the factory, it has gone through shakedown test, but the user still should check all mechanisms of the machine and adjust them before actually using it, so as to let it work better.

i. Routine check

1. Check engine oil

Warning! The engine shall be filled with 0.6L of engine oil. If the level of engine oil is lower than the normal one when the user is using the engine, the engine will be severely damaged!

Warning! Please use clean and high-quality engine oil for four-stroke engines. Use of dirty oil or any other type of engine oil will shorten the engine's service life.

- Put the engine in a horizontal position.
 - Screw out the oil dipstick of the engine and clean it by wiping it (See Fig.2)
 - Insert the oil dipstick into the oil filler (don't engage their threaded parts)
 - Take out the oil dipstick to check oil level, if it's within the marked range of the oil dipstick, it is OK.
 - SAE15W — 40 engine oil is a recommended general-purpose lubricant, and is suitable for a common ambient temperature. (See Table 1)
- #### 2. Check lubricant in reduction box

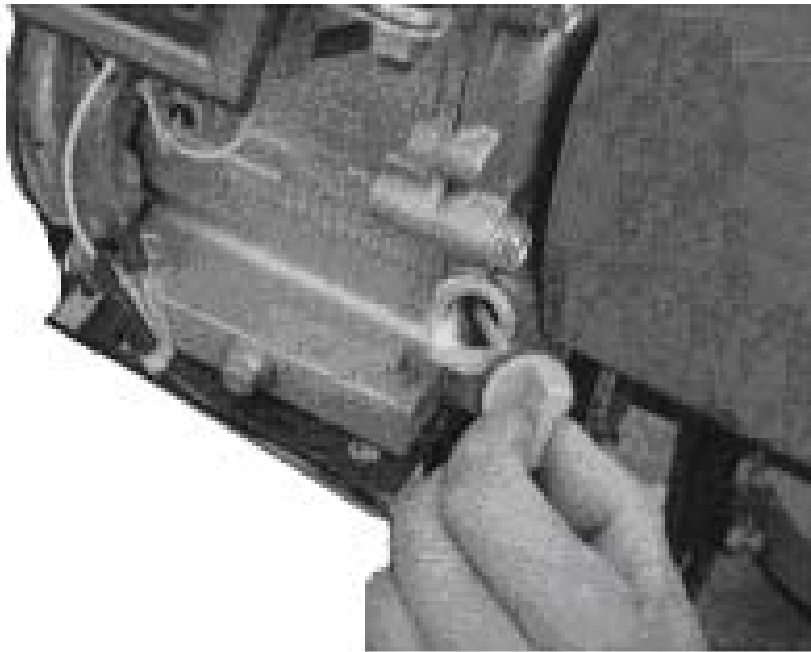

Figure 2

- Put the tiller on a horizontal ground and screw out the plug (See Fig.4)
- Advise append appropriate lubricant to the reduction box every 50 hours.
- Recommended lubricant is Calcium base grease .

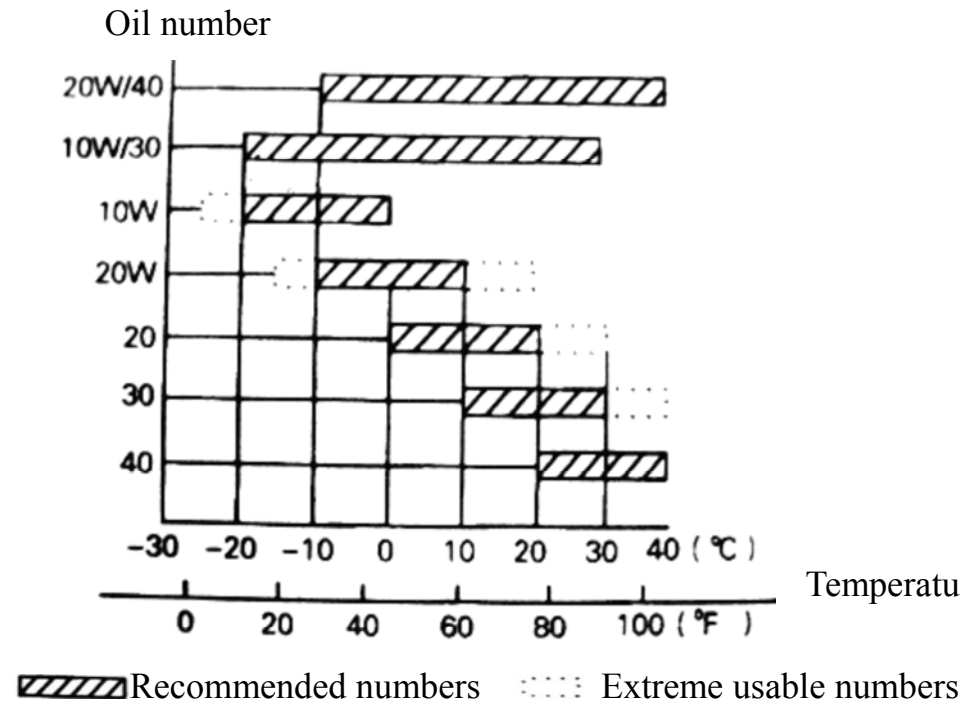

Table 1

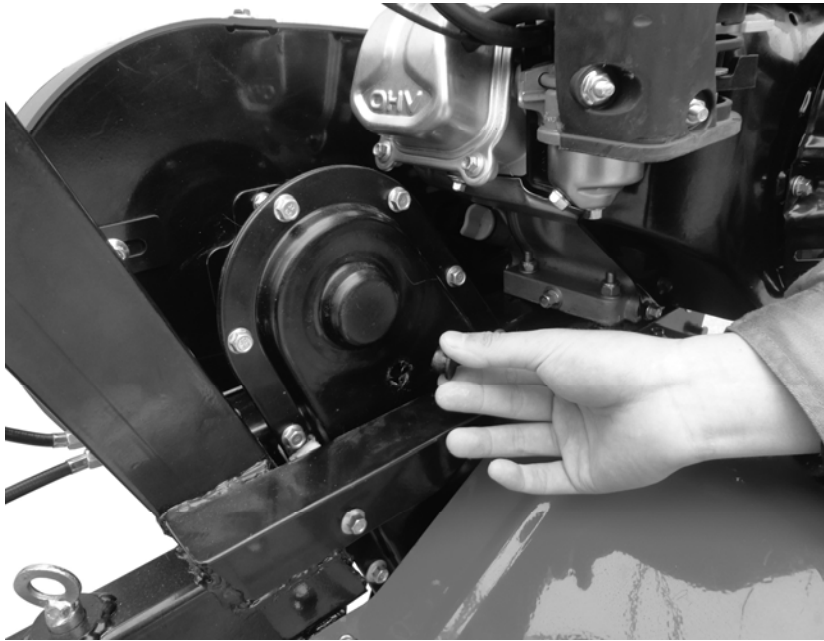

Figure 4

3. Check air filter

Warning! Never try to run the engine without the air filter, if so, the engine will be worn more quickly.



Figure 5

ii. Status adjustment of the tiller

1. Adjustment of handle frame

Note: Before adjusting height of handle frame, please put the machine on a flat horizontal ground to prevent it from accidental falling.

● Loosen the lifting handle and select the hole in an appropriate position, then adjust the handle's cross bar to as high as user's waist, then turn the lifting handle to tighten it (See Fig. 5).

2. Adjustment of tilling depth

● By adjusting height of damping lever, tilling depth can be adjusted. Specifically, adjusting the lever downward will increase tilling depth, and adjusting it upward will decrease tilling depth. (See Fig.6)

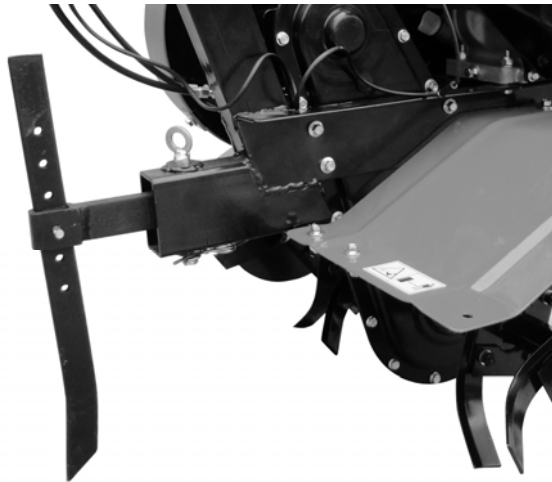

Figure 6

3. Adjustment and use of clutch

Note: Before using the clutch, lower the engine speed.

● By “engage ” and “disengage ”of the clutch, the user can control output of engine's power.

● When the user holds tight the clutch lever, the clutch is engaged and transmits engine power to the tiller and tilling blades begin to rotate. (See Fig.7)



Figure 7



Figure 8

● When the user releases clutch lever, clutch will be disengaged, and the engine power can't be transmitted to the tiller, and tilling blades stop rotating. (See Fig 8)

Note: improper adjustment of clutch cable will affect normal use of the product.

● First confirm tension of clutch cable. Normally the cable shall have a 4~8mm degree of freedom, if not, please loosen the locking nut and adjust the cable, and tighten the locking nut after finishing adjustment. (See Fig.9)

● If necessary, the user may start the engine to check whether the clutch can engage and disengage properly.

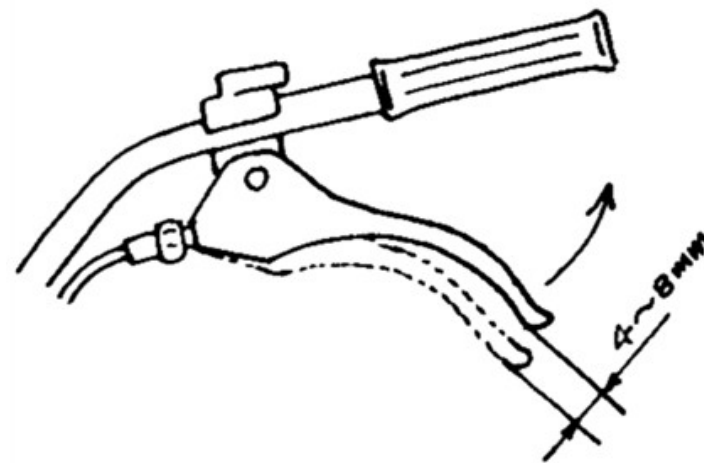

Figure 9

4. Adjustment of belt tension

● If belt tension isn't in the normal tension range, it needs adjustment. Please loosen the engine's 4 mounting bolts (See Fig.10 and Fig.11).

● After loosen the engine's 4 mounting bolts, then if belt is too loose, push the engine forward, and if belt is too tight, move backward the engine till belt tension falls in the normal range, finally tighten engine's mounting bolts and connection plate's mounting bolts. (See Fig.12)

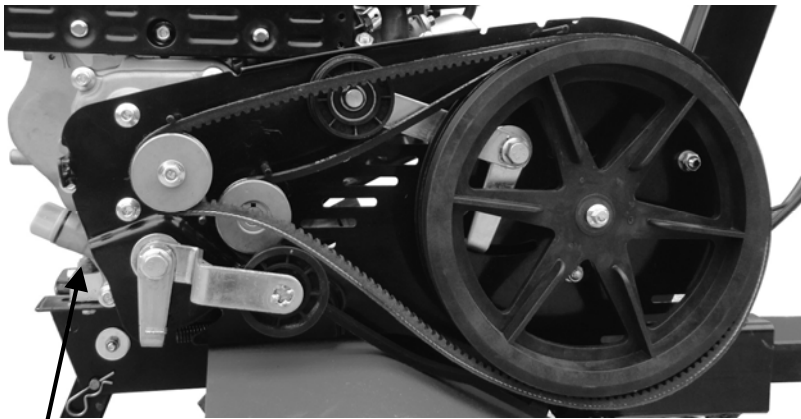

Figure 10
Engine mounting bolt

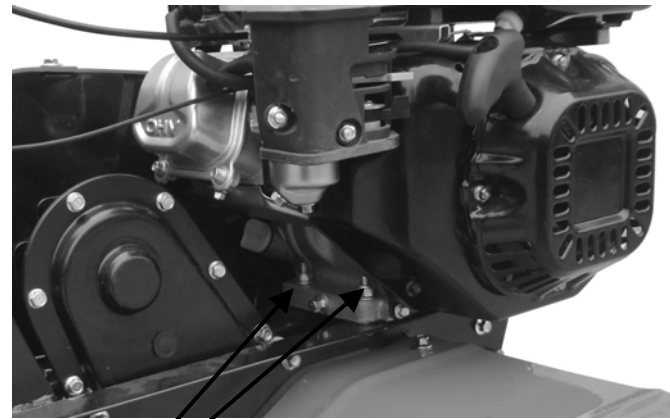

Figure 11
Engine mounting bolt

5. Adjustment of accelerator cable

● Idling within normal speed range: 1800 ± 100 Rpm; within high speed range: 3600 ± 50 rmp, and it can be adjusted using a speed counter.

● Method of confirming speed and adjustment of it

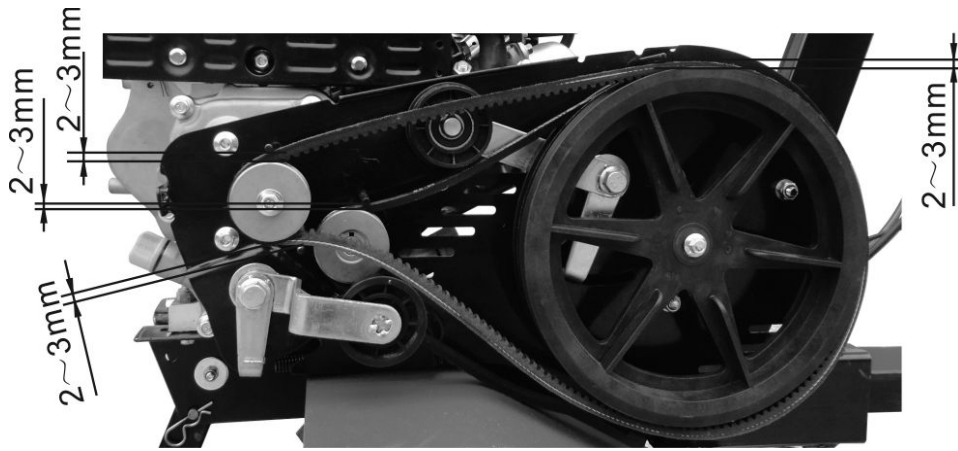

Figure 12



Figure 13 Accelerator valve regulator

1. Turn the accelerator valve regulator on the handle frame to the maximum adjustable position without any load, and check if speed counter shows the speed is 3600 ± 50 , and then turn the accelerator valve regulator to the minimum adjustable position and check whether speed counter shows the speed is 1800 ± 100 .

2. If the speed value displayed by the speed counter isn't within the said ranges, it is necessary to adjust the gasoline engine.

Steps to adjust the engine:

- 1) Observe whether connection points of the accelerator cable are loose or have broken off, if so, retighten them to their original places.
- 2) Turn accelerator valve regulator on the handle frame to the maximum adjustable position without load, and then adjust the speed adjusting bolt of the gasoline engine's accelerator operation mechanism to a proper position.
- 3) After long work, the user may adjust the fine-adjusting bolt of the accelerator cable to adjust the engine.

6. Use the clutch of reverse gear

Warning! Before using the clutch of reverse gear, lower the engine speed.

- By “engage ” and “disengage ”of the clutch of reverse gear, the user can control output of engine’s power.
- When the user holds tight the clutch lever, the clutch is engaged and transmits engine power to the tiller and tilling blades begin to reverse rotate. (See Fig.14)



Figure 14



Figure 15

- When the user releases clutch lever, clutch will be disengaged, and the engine power can’t be transmitted to the tiller, and tilling blades stop rotating. (See Fig 15)

Note: When using the clutch of reverse gear , especial pay attention to safety . Sure , improper

adjustment of clutch cable will affect normal use of the product.

7. Adjustment of front wheel

- 1) Adjust front wheel of tiller to the state shown in Fig. 15 when it is going to drive on the road.
- 2) Adjust the front wheel of tiller to the state shown in Fig.16 when it is going to till the field.



Figure 15

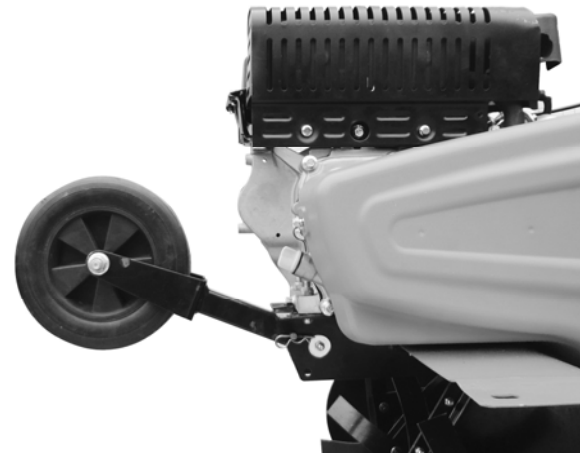

Figure 16

Chapter V Running

i. Steps to start it

Warning! Before starting the engine, gear shift lever must be put in the neutral position. Clutch lever shall be released.

1. Set the fuel valve to the ON (open) position

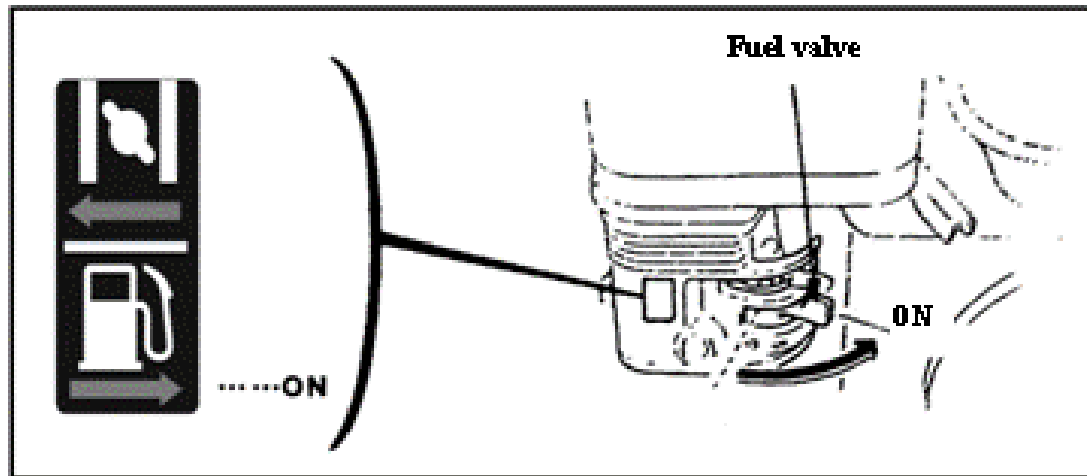

2. Put the choke lever to the CLOSE position.

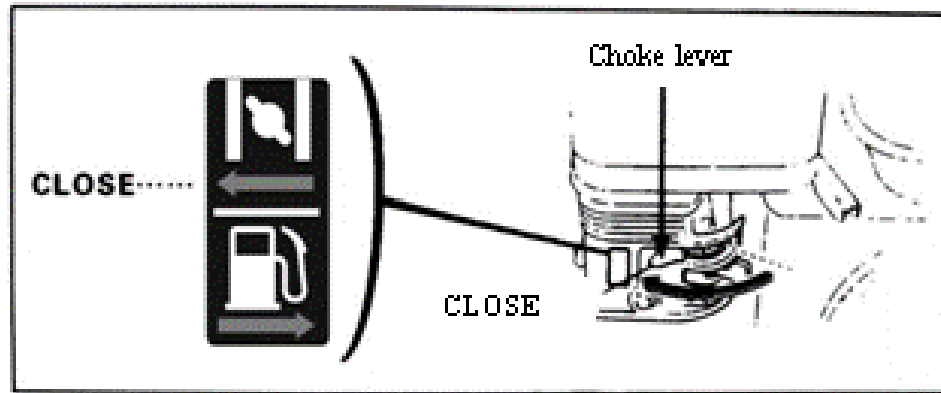

3. Turn the accelerator valve regulator lever slightly to the direction for high speed

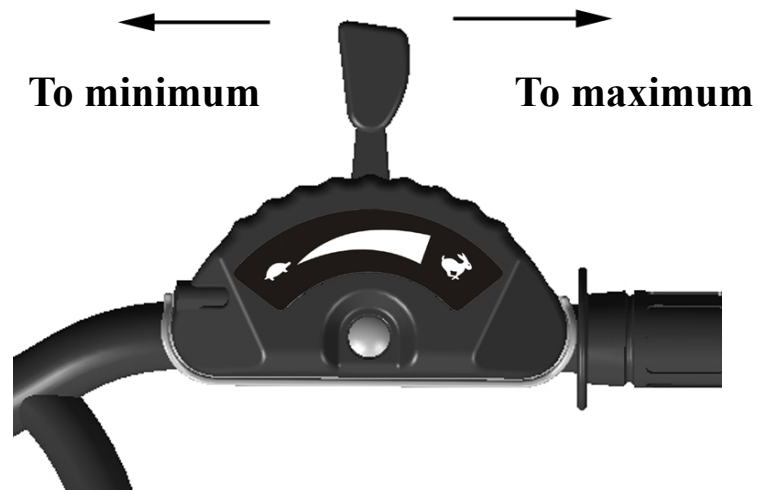

4. Put the engine switch to ON (open) position.



Slightly pull the starter cable until you feel a resistance, and then pull it out fast with a big force.

Note! Never abruptly release the lever, which would let it bounce back to hit and damage the engine, so if you want to release, slowly let it back in the direction of the starter cable's resilience.

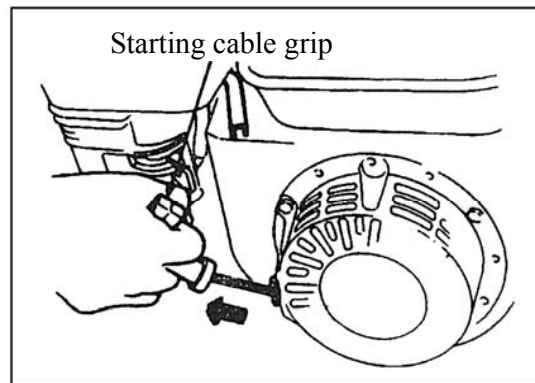

5. After the engine has warmed up, slowly push the choke lever to OPEN position.

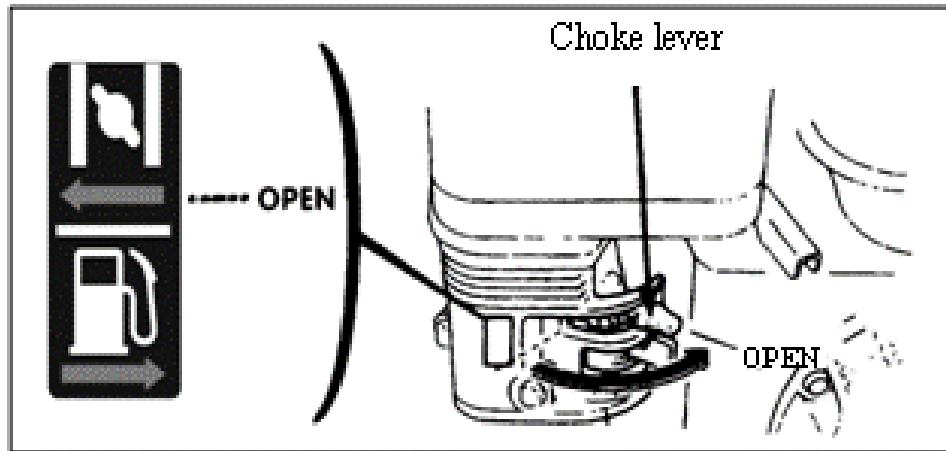

6. Use the accelerator valve regulator (or throttle valve lever) to regulate the engine speed to the need level.

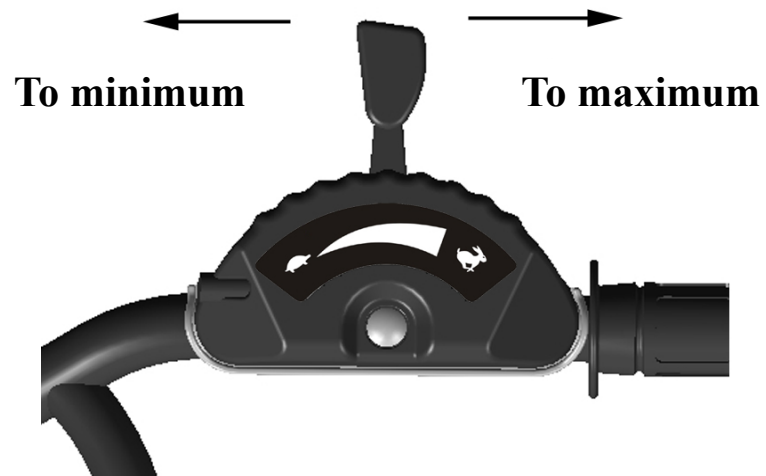

ii. How to stop the engine

- Under an emergency, the engine can be stopped, which means the user can directly shift the engine switch to OFF position.

- Under a normal condition, the steps to stop the engine are as follows:

1. Push the accelerator valve regulator to the minimum position.

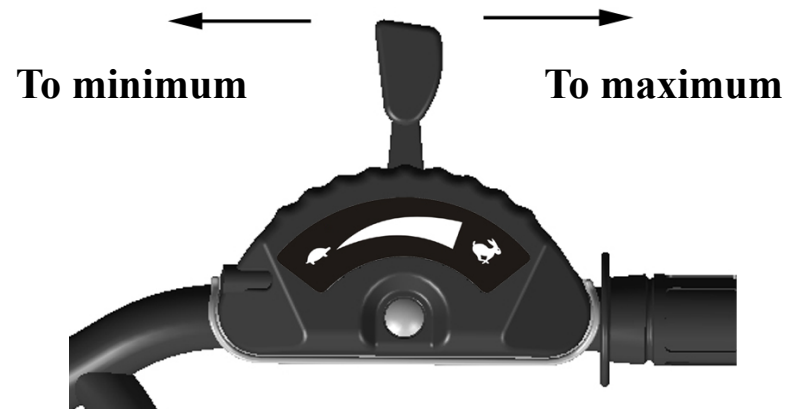

2. Turn the engine switch to OFF position.

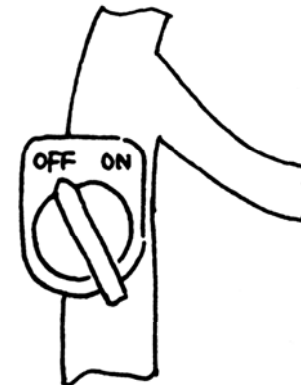

3. Shift the fuel valve switch to OFF (closed) position.

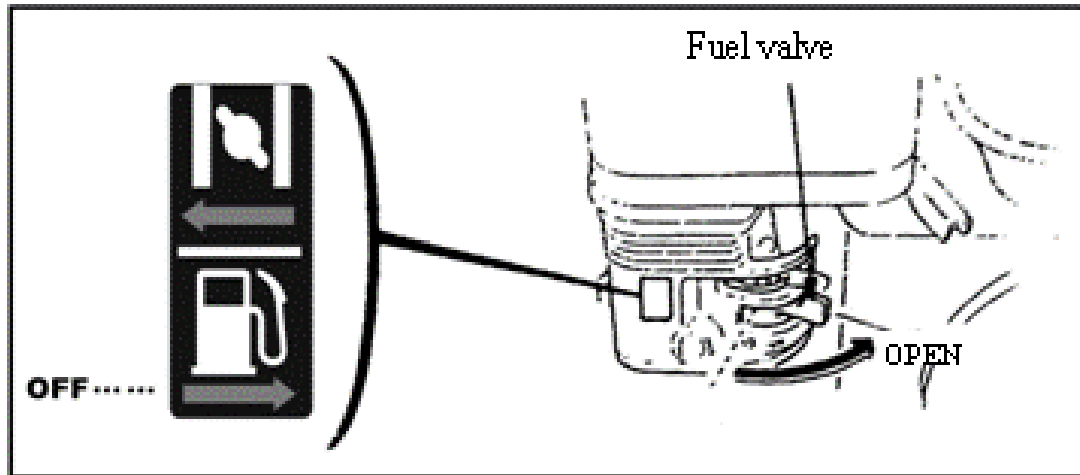

Chapter VI Maintenance of gasoline engine

Warning!

- Stop the engine before any maintenance.
- In order to prevent inadvertent starting of the engine, please put the engine switch on OFF (stopped) position and pull off the line connecting spark plug.
- Check and maintenance of the engine can only be conducted by an authorized distributor, unless the user itself has proper tools and materials for check and maintenance, and has the ability to repair and maintain the engine.

Note:

- If you want to maintain a good performance of the engine, it must undergo regular check and adjustment. The routine maintenance guarantees the long-term service life. In the following table, the required maintenance intervals and the items to be maintained will be described.

Maintenance cycle As per months shown Or actual running hours, whichever is earlier		Daily use	After first month or after 20 hours	Every season or 50 hours	Every 6 months or 100 hours	Every year or 300 hours
Item						
Engine oil	Check oil level	●				
	Change oil		●		●	
Lubricant in reduction box (applicable to some models)	Check lubricant	●				
	Append lubricant		●	●		
Air filter	Check	●				
	Clean	●				
Spark plug	Check and clean				●	
Spark arrester (optional)	Clean				●	
Fuel tank and filter	Clean			●		
Air valve	Check-adjust					●
Fuel line	Check	Every two years (if necessary, change it) ●				

Note!

1. If the machine is to be used in a dusty condition, maintenance frequency shall be increased.

2. The user may not disassemble the engine unless he has proper tools and mechanic repair ability.

Some items can be maintained by an authorized distributor.

1. Change of engine oil

Drain engine oil after warming up the engine by running for 5 minutes. Then check the drainage of oil.

- ① Loosen engine oil dipstick and oil drain bolt to drain the oil.
- ② Screw back the oil drain bolt and tighten it.
- ③ Refill the engine with recommended engine oil.
- ④ Refit the engine oil dip stick.

The volume of engine oil shall be 0.6 L.

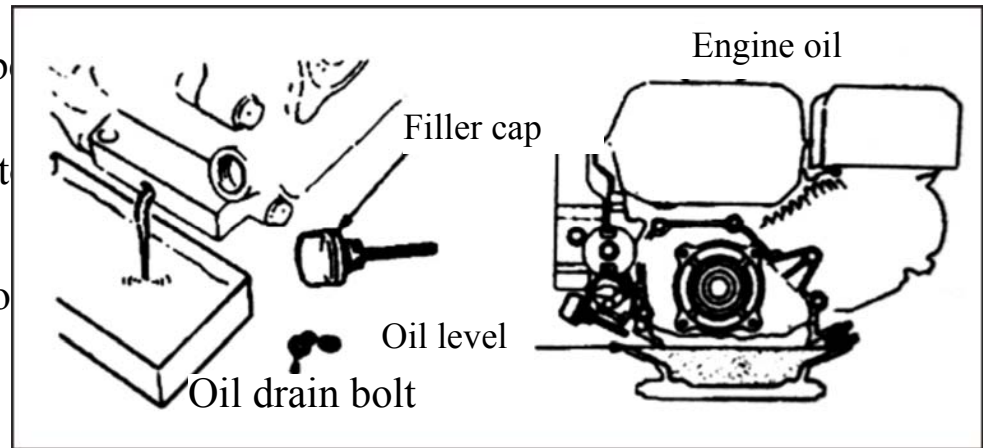

2. Maintenance of air filter

A dirty air filter will obstruct air into the carburetor. So in order to prevent fault of carburetor, the air filter shall be maintained regularly. If the engine is to work in a dusty environment, its maintenance frequency should be increased.

Warning! Never use gasoline or low-burning-point detergent to clean air filter element because they may cause burning.

Note! Never try to run the engine without an air filter, because such operation would cause quick wear of the engine.

- ① Take apart the wing nut and air filter housing and take out the filter element.
- ② Use an unflammable or high-burning-point detergent to clean filter element and let it dry up.
- ③ Drench filter element with engine oil and then squeeze the oil out.
- ④ Refit filter element and air filter housing.

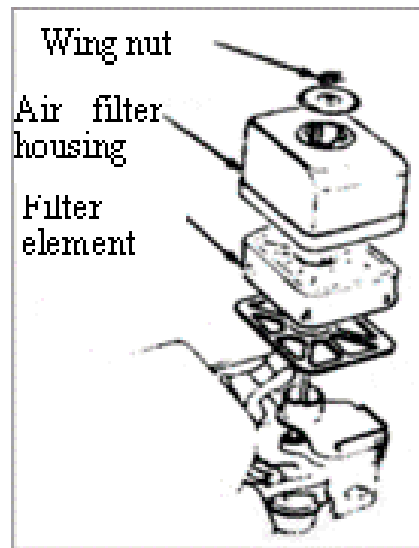

3. Maintenance of spark plug

Note! Never use any spark plug with an incorrect heat range. In order to guarantee normal running of the engine, the spark plug shall have an appropriate gap without deposit on it.

- ① Use a special socket spanner to detach the spark plug.

Special socket spanner for spark plug

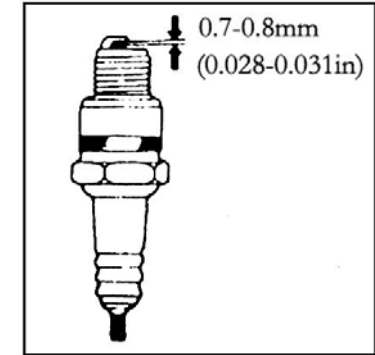
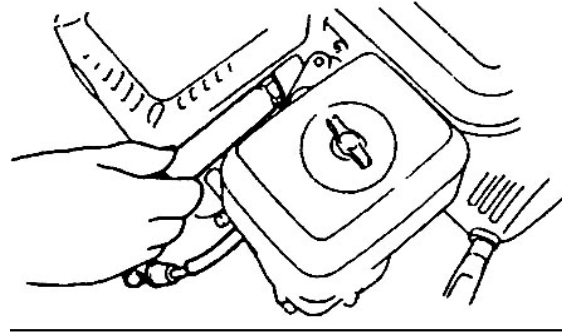
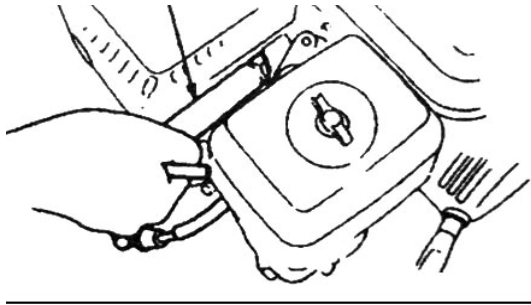

Warning! If the engine has just stopped running, the muffler will be very hot. So keep clear of hot temperature to avoid scald.

② Check the spark plug. If it is obviously worn or the insulation has any crack or damage, please replace it, if it has too much carbon deposition; use a wire brush to clean it.

③ Use a clearance gauge to measure the spark plug gap, correct value of which shall be 0.70to 0.80mm.

④ Check whether spark plug washer is good. In order to avoid thread alternating, use hand to screw spark plug in first.

⑤ After screwing spark plug to the bottom, use a special socket spanner to tighten it and the washer below it.

Note! If the spark plug is a new one, tighten the spark plug further by 1/2 turn after the washer is pressed down tightly.

If the spark plug has been used, tighten it further by 1 / 8 — 1 / 4 turn after the washer is pressed down tightly.

The spark plug must be tightened adequately, or it will be heated and damage the engine.

Warning! If the engine has just stopped running, the muffler will be very hot; don't work on the engine before it has cooled.

Note! Spark arrester must be maintained every 100 hours to ensure it can work effectively.

- ① Loosen out two 4mm screws from the exhaust deflection pipe and take apart the exhaust deflection pipe.
- ② Loosen out four 5mm screws from the muffler guard to detach the muffler guard.
- ③ Loosen out the 4mm screws from the spark arrester to detach it from the muffler.
- ④ Use a brush to remove carbon deposition from the mesh enclosure of the spark arrester.

Note! No cracks or damage in the spark arrester is allowed. If there is any crack or damage, replace the spark arrester.

5. Idling adjustment of the carburetor

- ① Start the engine to warm it up to the normal temperature.
- ② When engine is idle running, adjust the throttle valve's limit screw to set the normal idling speed.

Normal idling speed: 1800 ± 150 rpm

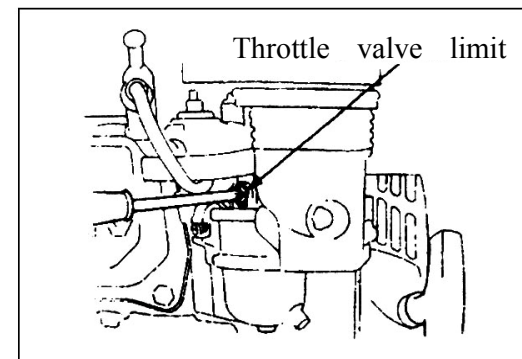

Chapter VII Maintenance of tiller

Due to wear from running, friction and change of load, the tiller's bolts may get loose, and parts and components may get worn, causing lower power of the gasoline engine, higher fuel consumption rate and other faults that will affect use of the tiller. In order to keep the above adverse conditions to a minimum level, it is necessary to strictly and regularly conduct maintenance of the tiller, so that it can maintain a good technical condition and have a longer service life.

i. Running in:

1. Please refer to the manual for information about running-in of the gasoline engine.
2. A new or overhauled tiller shall work for one hour without load first, then work for another nine hours, then the machine can be used for normal farming.

ii. Technical maintenance of tiller

1. Maintenance per shift (before and after each shift of work)

- ① Listen and watch to check if there is any abnormal phenomenon like abnormal noise, overheating, loose bolts, etc.
- ② Check if there is any oil leakage from the gasoline engine .
- ③ Check if oil levels of the gasoline engine are between the upper and lower marks of its oil level indicators
- ④ Timely remove dirt, slime, weeds and oil stains on the whole machine and its accessories.
- ⑤ Keep the farming record.

2. First-level maintenance (every 150 hours of work)

① Conduct all items of maintenance for each shift.

② Clean reduction box , and change grease

3. Second-level maintenance (every 800 hours of work)

① Conduct all items of the maintenance for every 150 hours of work.

② Check all gears and bearings, if any of them is severely worn, replace it.

③ If any of the tiller's other parts and components, such as any tilling blade or bolt, is damaged, please replace it.

4. Technical check and repair (every 1500-2000 hours of work)

① Disassemble the whole machine at a local authorized service shop to clean and check it, and if any of the parts and components is severely worn, replace it or repair it if it is appropriate to do so.

5. Repair and maintenance of gasoline engine shall be conducted as per the manual.

iii. Table of mini-tiller's technical maintenance (an item marked with √ shall be maintained)

Work interval Content of maintenance	Every day	After 8 hours of work under a half load	After the first month or after 20 hours	After the third month or after 150 hours	Every year or 1,000 hours	Every 2 years or 2,000 hours
Check and tighten bolts and nuts	√					
Check and add new engine oil	√					
Clean and change engine oil		(First time)	(Second time)	√(third time and thereafter)		
Check if there's oil leakage	√					
Clean dirt, weeds, and oil stains	√					
Solve problems	√					
Adjust operating parts	√					
Tension belt	√					
Gears and bearings					√	

iv. Long storage of mini-tiller

If the tiller need be stored for a long time, the following measures should be taken to prevent rust and erosion.

1. Seal up and store gasoline engine as per requirements in the manual of gasoline engine.
2. Clean dirt and slime on the outer surface,
3. Drain lubricant from the transmission box and fill it with new lubricant.
4. Apply anti-corrosion oil on unpainted part of the non-aluminum-alloy surface.
5. Keep the product in a well ventilated, dry and safe indoor place.
6. Properly keep the tools, quality certificate and operation manual attached to the machine.

Chapter VIII Trouble shooting

If the engine can't be started, please check

1. Whether the engine switch is in the ON position,
2. Whether there is enough lubricant in the machine,
3. Whether fuel valve is in the ON position,
4. Whether there is fuel in the fuel tank,

5. Whether fuel can be delivered into carburetor, to check this, the user can loosen drain bolt of carburetor and set the fuel valve to the ON position.

Warning! : If any fuel is spilled out, thoroughly remove it and let it dry up before checking spark plug or starting the engine, because fuel spilled out and its vapor may cause a fire.



6. Whether the spark plug can spark.

a. Pull off the spark plug cap, remove dirt from it, then detach the spark plug.

b. Fit spark plug cap over the spark plug.

c. Contact the metallic case of spark plug to engine's cylinder head. Slightly pull the starter to check if sparks are produced. If so, refit the spark plug and start the engine.

7. If the engine still cannot start, please repair it at an authorized distributor's shop.



隆鑫通用动力股份有限公司
Loncin motor co., Ltd.

详细地址：重庆市九龙坡区九龙工业园区华龙大道99号

服务电话：023 8980 5678/8980 8505

传 真：023-8906 7566

邮政编码：400052

Email: marketing@loncinengine.com

Website: www.loncinengine.com

PRINTED IN CHINA