

LONCIN 隆鑫

General Power Products

Welding & Generator Set

W190

W190D

W190DR

Owner's Manual



⚠ WARNING The generator is a potential source of electrical shock if misused. Do not expose the generator to moisture, rain or snow. Do not let the generator get wet, and do not operate it with wet hands.

Thank you for purchasing a generator/welder. We want to help you get the best results from your new generator/welder and to operate it safely. This manual contains the information on how to do that; please read it carefully.

This owner's manual describes the operation and maintenance of the W190/W190D generator/welder. All information in this publication is based on the latest product information available at the time of printing.

We reserve the right to make changes at any time without notice and without incurring any obligation. No part of this publication may be reproduced without written permission.

This manual should be considered a permanent part of the generator/welder and should remain with it if it is resold.

Safety Messages

Your safety and the safety of others are very important. We have provided important safety messages in this manual and on the generator/welder. Please read these messages carefully.

A safety message alerts you to potential hazards that could hurt you or others. Each safety message is preceded by a safety alert symbol  and one of three words: WARNING, CAUTION, or NOTICE.

These mean:

 **WARNING** Check that there is not any fuel spilling or fuel leaking. Filling before stopping engine is forbidden.

 **WARNING** Among engine exhaust emissions, there is toxic CO. so never use in enclosed room without good ventilation.

 **CAUTION** Before operation, be sure to add specified engine oil into the crankcase. Please refer to the OWNER'S MANUAL for further information.

 **NOTICE** Notice high temperature.

 **NOTICE** Vent, Notice high temperature.

Each message tells you what the hazard is, what can happen, and what you can do to avoid or reduce injury.

Damage Prevention Messages

You will also see other important messages that are preceded by the word NOTICE.

This word means:

 **NOTICE** Your generator/welder or other property could be damaged if you don't follow instructions.

The purpose of these messages is to help prevent damage to your generator/welder, other property, or the environment.

CONTENTS

1.SAFETY.....	4
1) Safety Label Location.....	4
2) Safety Information	5
2.COMPONENT IDENTIFICATION	7
3.CONTROLS.....	8
1) Engine Switch	8
2) Recoil Starter	8
3) Fuel Valve.....	8
4) Choke Rod.....	8
5) Circuit Breaker.....	9
6) Auto-throttle System.....	9
7) WELDING/AC Selector Switch.....	9
8) Welding Cable Termina.....	10
9) Welding Current Adjust System.....	10
4.GENERATOR/WELDER USE.....	10
1) Connections to a Building's Electrical System.....	10
2) AC Operation.....	11
3) Welding	12
4) Selecting the Correct Welding Current.....	12
5) Welding Cable Selection.....	13
6) Welding Duty Cycle.....	13
7) Polarity Selection.....	14
8) High Altitude Operation.....	14
9) Auto-throttle System.....	14
5.PRE-OPERATION CHECK	15
1) Engine Oil	15
2) Fuel Recommendation.....	16
6.STARTING THE ENGINE/STOPPING THE ENGINE.....	18
1) Starting the Engine.....	18
2) Stopping the Engine.....	18
7.MAINTENANCE.....	19
1) Maintenance Schedule.....	19
2) Tool Kit.....	20
3) Engine Oil Change	20
4) Air Cleaner Service	21
5) Fuel Sediment Cup Cleaning	22
6) Spark Plug Service.....	22
8.TRANSPORTING/STORAGE.....	23
9.TROUBLESHOOTING	26

10.SPECIFICATIONS.....	28
11.WIRING DIAGRAM.....	29
12.INSTALLATION OF OPTIONAL PARTS.....	33
1) Battery.....	33
2) 4-wheel kit installation.....	34

1.SAFETY

1) Safety Label Locations

These labels warn you of potential hazards that can cause serious injury. Read them carefully.

If a label comes off or becomes hard to read, contact your generator dealer for a replacement.

WARNING Among engine exhaust emissions, there toxic CO. so never use in enclosed room without good ventilation.

WARNING Check that there is not any fuel spilling of fuel leaking . Filling before stopping engine is forbidden.

CAUTION Before operation, be sure to add specified engine oil into the crankcase. Please refer to the OWNER' S MANUAL for further Information.

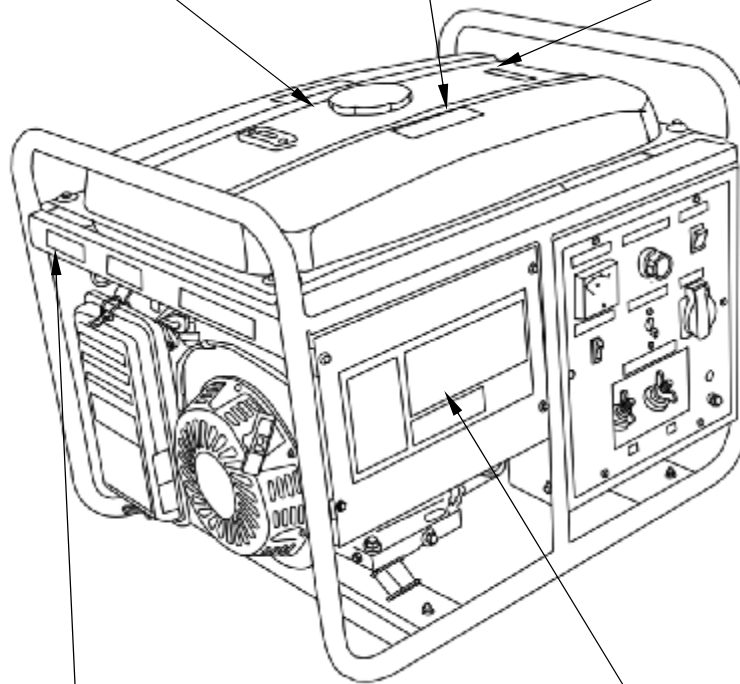

CAUTION		LONCIN LCW190D		
LONCIN WELDING & GENERATOR SET				
GENERATOR	Rated Voltage	220V	Electric welder	
	Rated Frequency	50Hz		
	Rated Output	2.0kW		
	Maximum Output	2.2kW		
	Power Factor	1.0		
			Rated Current	140A
			Current Adjust Range	50~190A
			Rated Voltage DC	26V
			Welding Rod Dia.	2.6~5.0mm
CAUTION		WARNING		
<p>1. Before operation, be sure to add specified engine oil into the crankcase.</p> <p>2. For details, please refer to the OWNER' S MANUAL</p>		<p>Oil Alarming System</p> <p>Automatically stop the engine while oil level is too low.</p>		
		<p>Don' t use the generator indoor to avoid carbonic oxide poisoning.</p>		

2) Safety Information

Our generator/welder are designed to give safe and dependable service if operated according to instructions. Read and understand this owner's manual before operating your generator/welder. You can help prevent accidents by being familiar with your generator's controls, and by observing safe operating procedures.

Operator Responsibility

- I Know how to stop the generator /welder quickly in case of emergency.
- I Understand the use of all generator/welder controls, output receptacles, and connections.
- I Be sure that anyone who operates the generator/welder receives proper instruction. Do not let children operate the generator/welder without parental supervision.

Carbon Monoxide Hazards

- I Exhaust contains poisonous carbon monoxide, a colorless and odorless gas. Breathing exhaust can cause loss of consciousness and may lead to death.
- I If you run the generator/welder in an area that is confined, or even partially enclosed, the air you breathe could contain a dangerous amount of exhaust gas. To keep exhaust gas from building up, provide adequate ventilation.

Electric Shock Hazards

- I The generator/welder produces enough electric power to cause a serious shock or electrocution if misused.
- I Using a generator/welder or electrical appliance in wet conditions, such as rain or snow, or near a pool or sprinkler system, or when your hands are wet, could result in electrocution. Keep the generator/welder dry.
- I If the generator/welder is stored outdoors, unprotected from the weather, check all electrical components on the control panel, before each use. Moisture or ice can cause a malfunction or short circuit in electrical components which could result in electrocution.
- I Do not connect to a building's electrical system unless an isolation switch has been installed by a qualified electrician.

Fire and Burn Hazards

- I The exhaust system gets hot enough to ignite some materials.
 - Keep the generator/welder at least 1 meter (3 feet) away from buildings and

other equipment during operation.

- Do not enclose the generator/welder in any structure.
- Keep flammable materials away from the generator/welder.
- I The muffler becomes very hot during operation and remains hot for a while after stopping the engine. Be careful not to touch the muffler while it is hot.
 - Let the engine cool before storing the generator/welder indoors.
- I Gasoline is extremely flammable and is explosive under certain conditions. Do not smoke or allow flames or sparks where the generator/welder is refueled or where gasoline is stored. Refuel in a well-ventilated area with the engine stopped.
- I Fuel vapors are extremely flammable and may ignite after the engine has started. Make sure that any spilled fuel has been wiped up before starting the generator/welder.
- I Use adequate eye protection. Eye protection is of the utmost importance, not only for the operator, but also for any other personnel in the vicinity while welding is being done. Eye hazards include arc glare, reflected glare, stray flashes, sparks, and flying bits of molten metal.
- I Looking at a welding arc with unprotected eyes may produce severe pain and even temporary blindness.
- I Use a helmet or hand-held shield with #10 or darker filter lens.
Filter lenses eliminate the harmful effects of infrared and ultraviolet radiation from the arc and reduce the glare from the arc light as well.
- I Wear protective clothing such as leather gloves, cap, sleeves, jacket, apron, and high-top safety shoes. All outer clothing must be free of oil and grease.

FACE SHIELD

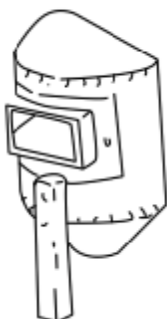

GLOVES



SAFETY SHOES



APRON



2.COMPONENT IDENTIFICATION

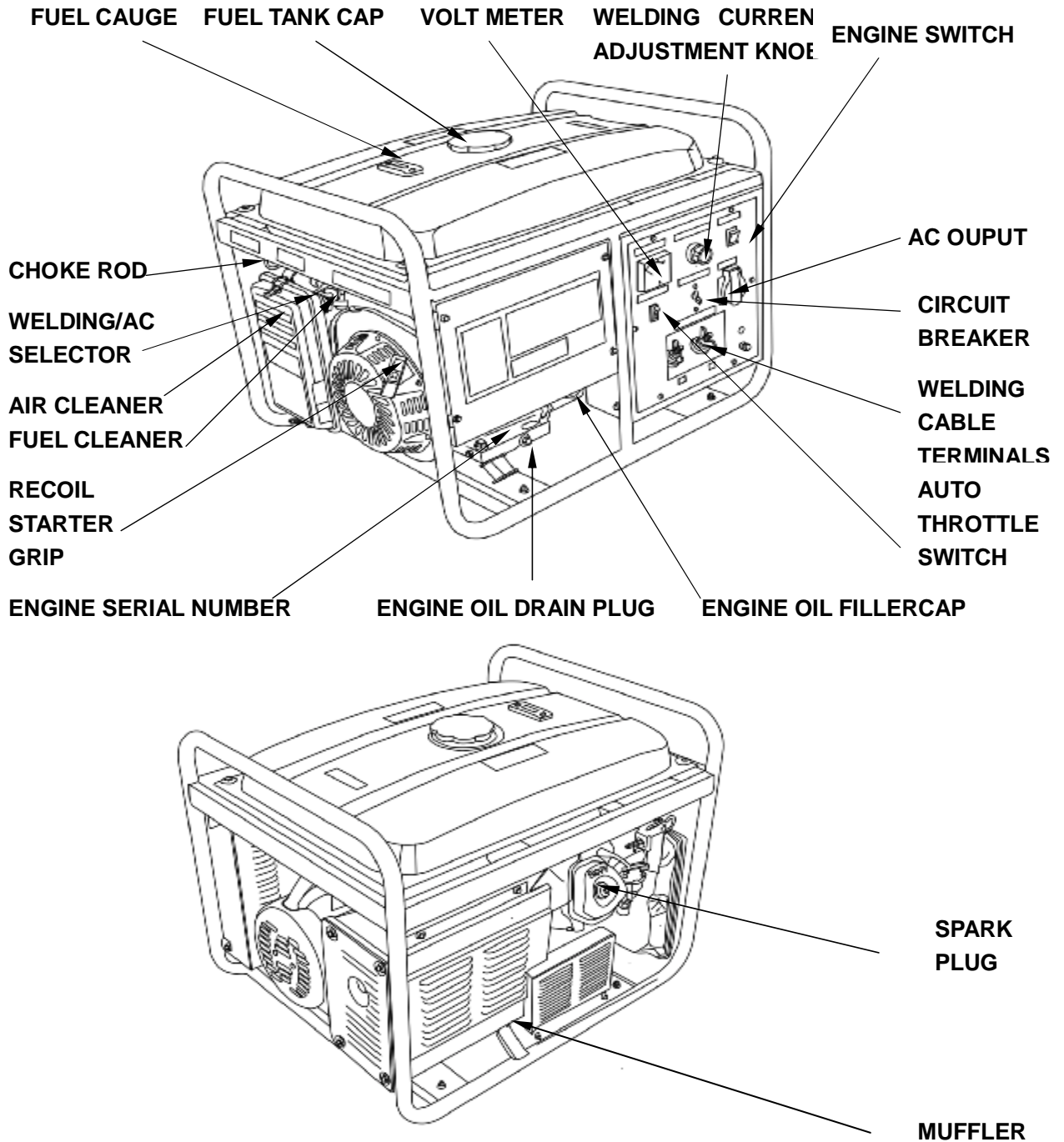

- I Record the engine and frame serial numbers for your future reference. Refer to these serial numbers when ordering parts, and when making technical or warranty inquiries
- Engine serial number: _____

3.CONTROLS

1) Engine Switch(Fig.1)

To start and stop the engine.

Switch position:

OFF: To stop the engine.

ON: To run the engine.

START: To start the engine. (Electric & Remote start)



ENGINE SWITCH

Fig.1

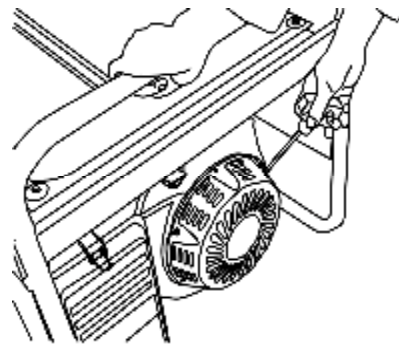

Fig.2

2) Recoil Starter(Fig.2)

To start the engine, pull the starter grip lightly until resistance is felt, then pull briskly.

NOTICE Do not allow the starter to snap back against the engine. Return it gently to prevent damage to the starter.

3) Fuel Valve(Fig.3)

The fuel valve is located between the fuel tank and carburetor. When the valve fuel lever is in the ON position, fuel is allowed to flow from the fuel tank to the carburetor. Be sure to return the lever to OFF position after stopping the engine.

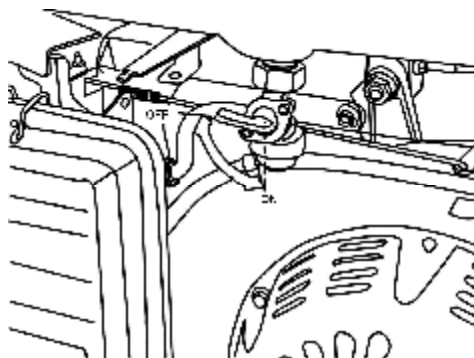

Fig.3

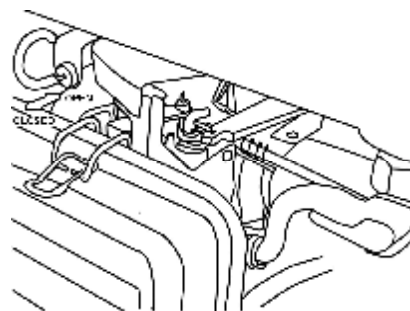

Fig.4

4) Choke Rod(Fig.4)

The choke is used to provide an enriched fuel mixture when starting a cold engine. It

can be opened and closed by operating the choke rod manually. Pull the rod out toward CLOSED to enrich the mixture.

5) **Circuit Breaker**(Fig.5)

The circuit breaker will automatically switch OFF if there is a short circuit or a significant overload of the generator at the receptacle. If the circuit breaker is switched OFF automatically, check that the appliance is working properly and does not exceed the rated load capacity of the circuit before switching the circuit breaker ON again.

The circuit breaker may be used to switch the generator power ON or OFF.

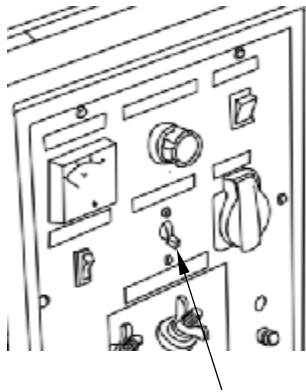

CIRCUIT BREAKER

Fig.5

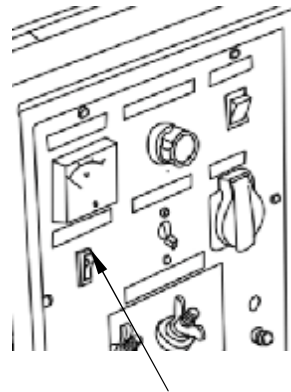

AUTO THROTTLE SWITCH

Fig.6

6) **Auto-throttle System**(Fig.6)

The auto-throttle system automatically reduces engine speed when AC loads are turned off or disconnected, or DC welding is discontinued. When AC loads are turned on or reconnected, or DC welding is resumed, the engine returns to the rated speed.

AUTO: Recommended to minimize fuel consumption and further reduce noise levels when no load is applied to the generator/welder.

OFF: The auto-throttle system does not operate.

Recommended to minimize warm up time when the engine is started.

7) **WELDING/AC Selector Switch**(Fig.7)

WELDING/AC Selector is located on the Air cleaner.

NOTICE

- A. To avoid accidental arcing, one cable end should be firmly attached to the object to be welded, and the electrode holder at the end of the cable should be held in the operator's hand when the WELDING selector is turned on.
- B. Under no circumstances should any type of electrical appliance be plugged into any of the AC receptacles when the selector is in the WELDING position. AC voltage is present at the AC receptacle at all times; regardless of the position of the WELDING/AC selector.

However, when this selector is in the WELDING position, the AC voltage is

unregulated and fluctuates considerably.

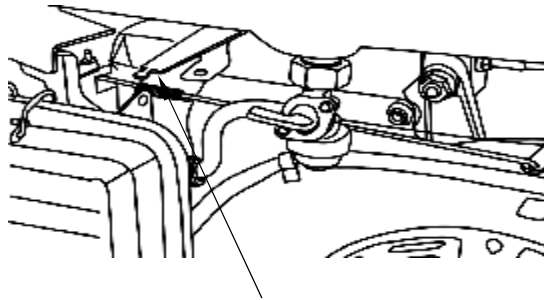

WELDING/AC SELECTOR

(Fig.7)



(Fig.8)

8) **Welding Cable Terminal**(Fig.8)

A separate terminal is provided for connection to the welding cable.

⚠ CAUTION Failure to use the proper gauge cable may lead to painful burns and/or damage to equipment. See table on page 18.

9) **Welding Current Adjust System**(Fig.9)

For best results, it is essential that current be adjusted properly according to the thickness of the materials to be welded and the method of welding. (See page. 17)

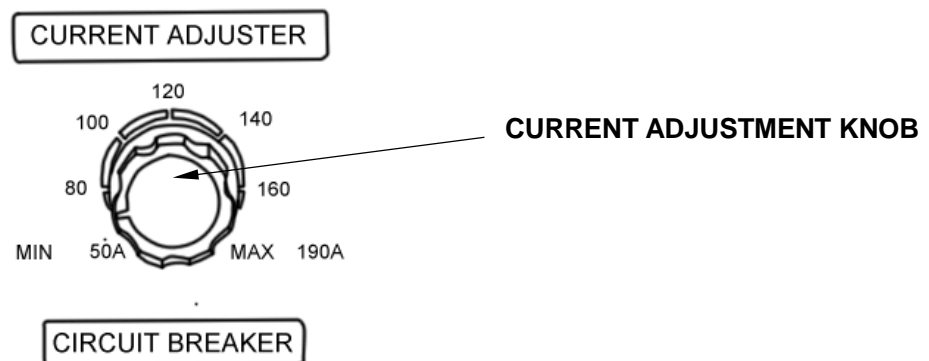

(Fig.9)

4.GENERATOR/WELDER USE

1) **Connections to a Building's Electrical System**

Connections for standby power to a building's electrical system must be made by a qualified electrician. The connection must isolate the generator power from utility power, and must comply with all applicable laws and electrical codes.

⚠ WARNING Improper connections to a building's electrical system can allow

electrical current from the generator to back feed into the utility lines. Such back feed may electrocute utility company workers or others who contact the lines during a power outage. Consult the utility company or a qualified electrician.

▲ CAUTION Improper connections to a building's electrical system can allow electrical current from the utility company to back feed into the generator. When utility power is restored, the generator may explode, burn, or cause fires in the building's electrical system.

In some areas, generators are required by law to be registered with local utility companies. Check local regulations for proper registration and use procedures.

2) AC operation

1. Start the engine.
2. Turn the WELDING/AC selector to AC position.

NOTICE Under no circumstances should any type of electrical appliance be plugged into any of the AC receptacles when the selector is in the WELDING position. AC voltage is present at the AC receptacles at all times regardless of the position of the WELDING/AC selector. However, when this selector is in the WELDING position, the AC voltage is unregulated and fluctuates considerably which could damage AC appliances.

3. Switch on the AC circuit breaker.
4. Plug in the appliance.

NOTICE

- A. Do not connect the generator/welder to a household circuit. This could cause damage to the generator to electrical wiring and appliances in the house.
- B. For continuous operation, do not exceed the rated load capacity (LCW190/LCW190D/LCW190DR:2.0KVA). In either case, be sure to consider the total power requirements of all connected appliances. Do not exceed the current limit specified for any one receptacle. Substantial overloading will switch off the circuit breaker. Marginal overloading may not switch off the circuit breaker, but it will shorten the service life of the generator/welder.
- C. If an overloaded circuit causes the AC circuit breaker to switch off, reduce the electrical load on the circuit, and wait a few minutes before resetting the circuit breaker.
- D. Be sure that all appliances are in good working order before connecting them to the generator. If an appliance begins to operate abnormally, becomes sluggish, or stops suddenly; turn off the circuit breaker and the engine switch immediately.

Then disconnect the appliance and examine it for signs of malfunction.

- E. Most appliance and power tool motors require more than the rated operating current for start-up. To match appliance power needs to generator capability, allow a sufficient generator power reserve to accommodate motor start-up requirements.

NOTICE Appliance and power tool manufactures usually list rating information near the model number or serial number.

3) Welding

⚠ WARNING Welding is potentially a very hazardous activity. It should only be attempted by a trained welder with a thorough knowledge of proper welding techniques and safety procedures. Be sure to read and follow the safety rules on page 3, 4 and 5 of this manual.

1. Put the Engine Switch in the OFF position. Turn the AC circuit breaker off and remove any plugs from the AC receptacles.

NOTICE Voltage is present at the welding terminals whenever the engine is running regardless of the position of the WELDING/AC selector.

2. Connect the welding cables to the welder's DC terminals (See page 17 and 18).

NOTICE Failure to use the proper gauge cable may lead to painful burns and/or damage to equipment. See table on page 18.

3. Start the engine and when it has warmed up fully, turn the Auto-Throttle Switch to the AUTO position.
4. Turn the WELDING/AC selector to the WELDING position.
5. Set the current adjustment knob to the proper current level for the job being done (See page 17).

4) Selecting the Correct Welding Current

Measure the thickness of the metal you are welding and then refer to the table below to select the proper electrode size and current setting

PLATE THICKNESS IN INCHES	ELECTRODE DIAMETER IN INCHES	CURRENT SETTING
UP TO 3/16	1/16	50-100
UP TO 1/4	3/32	100-150
ABOVE 1/8	1/8	124-175
ABOVE 7/4	5/32	150-200

NOTICE Always make a sample weld on a piece of scrap material to be sure you have chosen the correct electrode and current setting.

5) Welding Cable Selection

The table below shows the current carrying capacity of various lengths and gauges of standard copper welding cable. Whenever possible, refer to the cable manufacturer's recommendations.

Always allow a considerable safety margin when selecting welding cables. The cable's length and gauge (diameter), along with the material it is made from, all combine to determine how much current it can safely carry.

NOTICE An undersize welding cable will offer unacceptably high resistance to current flow. This high resistance will shorten the service life of the generator/welder, and can even make the welding cables become hot enough to cause painful burns.

	CABLE DIA.	LENGTH IN FEET*		
		0-50FT.	50-100FT.	100-250FT.
		CURRENT CAPACITY AMPERES		
1	.664	250	200	170
2	.604	200	195	—

NOTE: The cable lengths given in the table above are the combined lengths of the negative and positive cables.

6) Welding Duty Cycle

The duty cycle is the percentage of time that the welder can be operated in a given 10 minute period.

For example, at a rated output of 140 amperes, the LCW190/LCW190D/LCW190DR's duty cycle is 50%. This means that at 140 amperes, welding can be performed for a total of 5 minutes out of every 10 minute period. The duty cycle is longer at lower operating currents, and shorter at higher currents.

Current	190A	160A	140A	120A	Below 100A
Rate	15%	25%	50%	65%	100%

NOTICE Do not operate the welder beyond its duty cycle; doing so will decrease the performances and service life of the generator/welder.

7) Polarity Selection

The welding terminals are labeled “+” (positive) and “-”(negative). Changing the polarity of the cables will affect the weld. The correct polarity selection is dependent on the type of electrode you are using and the type of material you are welding; refer to the electrode manufacturer’s recommendations for best results.

For straight polarity, attach electrode cable to the negative terminal, and attach the ground cable to the positive terminal. To change to reverse polarity, reverse the cables.

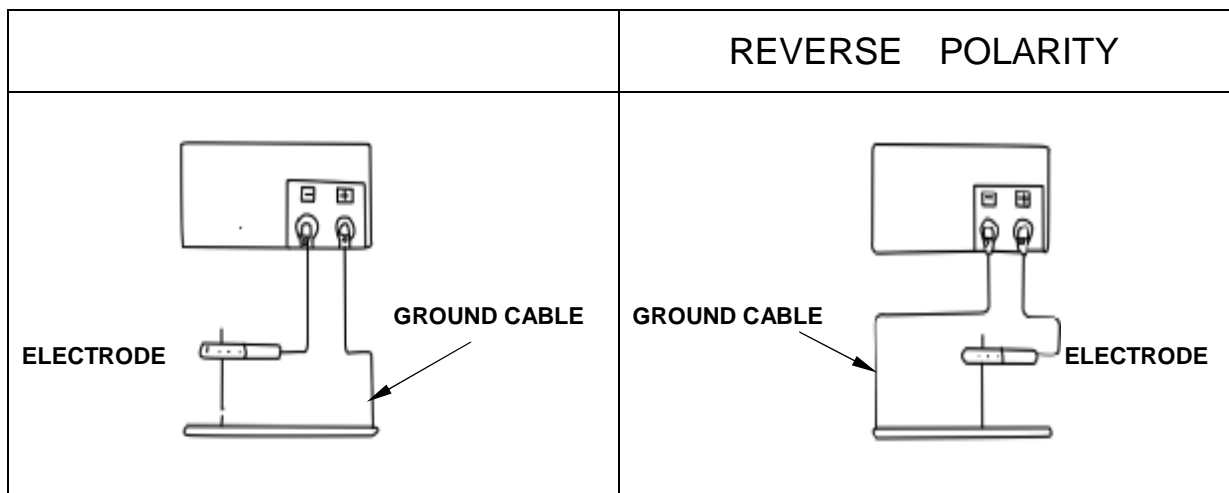

8) High Altitude Operation

At high altitude, the standard carburetor air-fuel mixture will be excessively rich. Performance will decrease, and fuel consumption will increase.

High altitude performance can be improved by installing a smaller diameter main fuel jet in the carburetor and readjusting the pilot screw. If you always operate the engine at altitudes higher than 6,000 feet above sea level, have an authorized generator dealer perform this carburetor modification.

Even with suitable carburetor jetting, engine horsepower will decrease approximately 3.5% for each 1,000 foot increase in altitude. The effect of altitude on horsepower will be greater than this if no carburetor modification is made.

NOTICE If a generator/welder jetted for high altitude is used at a lower altitude the air fuel mixture will reduce performance and may overheat or seriously damage the engine.

9) Auto-throttle system(Fig.10)

With the switch in the AUTO position, engine speed is automatically reduced when ALL

loads are turned OFF or disconnected. When appliances are turned ON or reconnected, the engine returns to rated speed. In the OFF position, the auto-throttle system does not operate.

The auto-throttle system will not respond to electrical loads of less than 1 ampere. Turn the auto-throttle to the OFF position to operate loads of less than 1 amp.

Appliances with large start-up power demands may not allow the engine to reach normal operating rpm when they are connected to the generator. Turn the auto-throttle to the OFF position and connect the appliance to the generator. If the engine still will not reach normal operating speed, check that the appliance does not exceed the rated load capacity of the generator/welder.

To avoid extended warm-up periods, keep the switch OFF until the engine reaches operating temperature.

The auto-throttle system is not effective for use with appliances that require only momentary power. If the tool or appliance will be turned ON and OFF quickly, the auto-throttle switch should be in the OFF position.

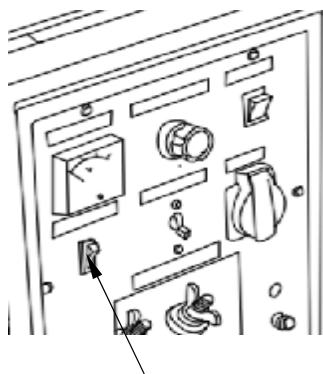

AUTO THROTTLE SWITCH

(Fig.10)

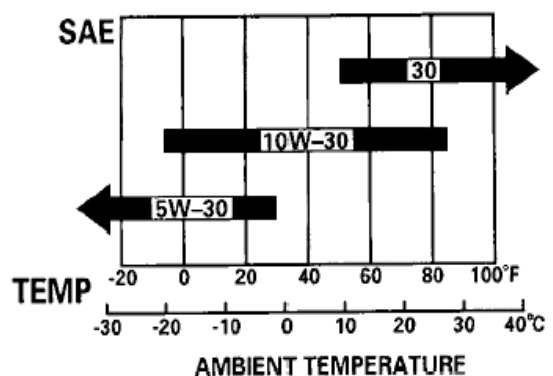

(Fig.11)

5. PRE-OPERATING CHECK

1) Engine oil (Fig.11)

NOTICE Engine oil is a major factor affecting engine performance and service life. Non-detergent and 2-stroke engine oils will damage the engine and are not recommended.

Check the oil level BEFORE EACH USE with the generator on a level surface with the engine stopped.

Use 4-stroke oil, or an equivalent high detergent, premium quality motor oil certified to meet or exceed U.S. automobile manufacturer's requirements for Service Classification SG, SF/CC, and CD. Motor oils classified SG, SF/CC; CD will show this designation on

the container.

SAE 10W-30 is recommended for general, all-temperature use. Other viscosities shown in the chart may be used when the average temperature in your area is within the indicated range.

1. Remove the oil filler cap and wipe the dipstick clean.
2. Check the oil level by inserting the dipstick into the filler neck without screwing it in.
3. If the level is low, fill to the top of the oil filter neck with the recommended oil.

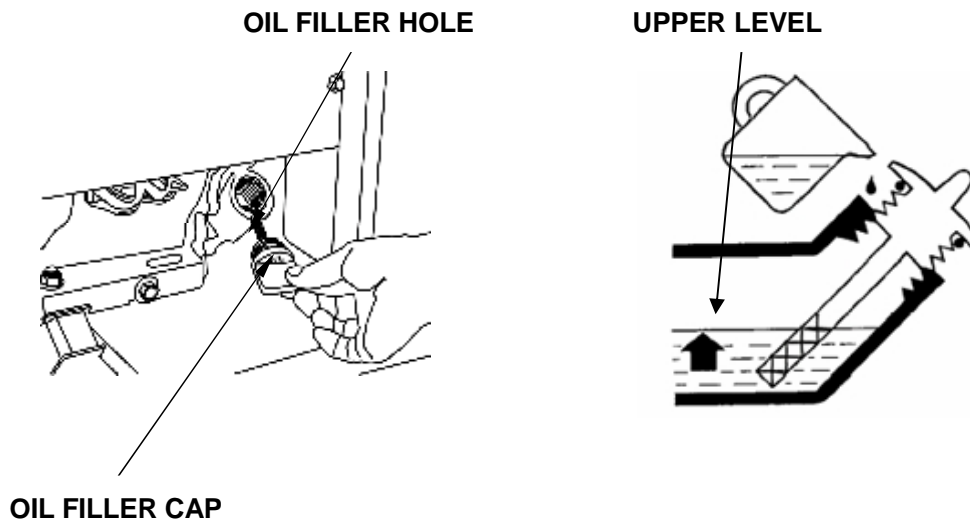

2) Fuel Recommendation

1. Check the fuel level gauge.
2. Refill the tank if the fuel level is low. Do not fill above the shoulder of the fuel strainer.

▲ WARNING

- I **Gasoline is extremely flammable and is explosive under certain conditions.**
- I **Refuel in a well-ventilated area with the engine stopped. Do not smoke or allow flames or sparks in the area where the engine is refueled or where gasoline is stored.**
- I **Do not overfill the fuel tank (there should be no fuel in the filler neck). After refueling, make sure the tank cap is closed properly and securely. Be careful not to spill fuel when refueling. Spilled fuel or fuel vapor may ignite. If any fuel is spilled, make sure the area is dry before starting the engine.**
- I **Avoid repeated or prolonged contact with skin or breathing of vapor.**
- I **KEEP OUT OF REACH OF CHILDREN.**

Fuel tank capacity: 25L

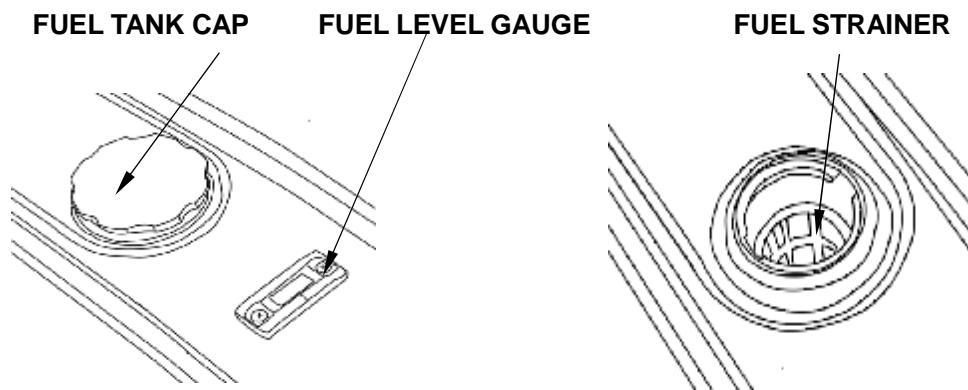

Use gasoline with a pump octane rating of 86 or higher.

We recommend unleaded gasoline because it produces fewer engine and spark plug deposits and extends exhaust system life.

Never use stale or contaminated gasoline or oil/gasoline mixture. Avoid getting dirt or water in the fuel tank.

Occasionally you may hear light “spark knock” or “pinging” (metallic rapping noise) while operating under heavy loads. This is no cause for concern.

If spark knock or pinging occurs at a steady engine speed, under normal load, change brands of gasoline. If spark knock or pinging persists, see an authorized generator dealer.

NOTICE Running the engine with persistent spark knock or pinging can cause engine damage.

Running the engine with persistent spark knock or pinging is misuse, and the Distributor’s Limited Warranty does not cover parts damaged by misuse.

Oxygenated Fuels

Some gasolines are being blended with alcohol or an ether compound to increase the octane. These gasoline are collectively referred to as oxygenated fuels. Some areas of the United States use oxygenated fuels to help meet clean air standards.

If you use an oxygenated fuel, be sure its pump octane rating is 86 or higher.

Ethanol (ethyl or grain alcohol)

Gasoline containing more than 10% ethanol by volume may cause starting and/or performance problems. Gasoline containing ethanol may be marketed under the name “Gasohol”.

Methanol (methyl or wood alcohol)

Gasoline containing methanol must contain cosolvents and corrosion inhibitors to protect the fuel system. Gasoline containing more than 5% methanol by volume may cause starting and/or performance problems and may damage metal, rubber and plastic parts of your fuel system.

MTBE (methyl tertiary butyl ether)

You may use gasoline containing up to 15% MTBE by volume.

Before using an oxygenated fuel, try to confirm the fuel's contents. Some states (provinces in Canada) require this information to be posted on the pump. If you notice any undesirable operating symptoms, switch to a conventional unleaded gasoline. Fuel system damage or performance problems resulting from the use of an oxygenated fuel are not the responsibility and are not covered under warranty.

NOTICE Oxygenated fuels can damage paint and plastic. Be careful not to spill fuel when filling your fuel tank. Damage caused by spilled fuel is not covered under warranty.

6.STARTING THE ENGINE/STOPPING THE ENGINE

1) Starting the engine

1. Make sure that the AC circuit breaker is in the OFF position, and that there are no welding cables attached to the DC terminals. The generator may be hard to start if a load is connected.
2. Turn the fuel valve to the ON position.
3. Pull the choke rod to the CLOSE position.
4. Make sure the auto-throttle switch is in the OFF position, or more time will be required for warm-up.
5. Move the engine switch to the ON position.
6. Pull the starter grip lightly until resistance is felt, then pull briskly.

NOTICE Do not allow the starter grip to snap back against the engine. Return it gently to prevent damage to the starter or housing.

7. Push the choke rod to the OPEN position as the Engine warms up.
8. If you wish to use the auto-throttle system, turn the auto-throttle switch to the AUTO position after the engine has warmed up for 2 or 3 minutes.

2) Stopping the engine

In an emergency:

1. To stop the engine in an emergency, turn the engine switch to the OFF position.

In normal use:

1. Turn the AC circuit breaker to the OFF position.
2. Move the engine switch to the OFF position.
3. Turn the fuel valve to the OFF position.

7.MAINTENANCE

Periodic maintenance and adjustment is necessary to keep the generator/welder in good operating condition. Perform the service and inspection at the intervals shown in the Maintenance schedule below.

⚠ WARNING Exhaust gas contains poisonous carbon monoxide. Shut off the engine before performing any maintenance. If the engine must be run, make sure the area is well ventilated.

NOTICE Use only genuine our parts or their equivalent for maintenance or repair. Replacement parts which are not of equivalent quality may damage the generator.

1) MAINTENANCE SCHEDULE

REGULAR SERVICE PERIOD Performed at every indicated month or operating hour interval, whichever comes first.		Each use	First month	Every 3months	Every 6months	Every Year
ITEM			Or 20Hrs. (3)	or 50 Hrs. (3)	or 100Hrs. (3)	or 300Hrs. (3)
Engine oil	Check level	0				
	Change		0		0	
Air cleaner	Check	0				
	Clean			0(1)		
GFCL receptacle	Check					
Sediment Cup	Clean				0	
Spark plug	Check-Clean				0	
Spark Arrester	Clean				0	
Valve clearance	Check-Adjust					0(2)
Fuel tank and strainer	Clean					0(2)
Fuel line	Check (Replace if necessary)	Every 2 years (2)				

(1) Service more frequently when used in dusty areas.

(2) These items should be serviced by an authorized generator dealer, unless the owner has the proper tools and is mechanically proficient. See the Shop Manual .

(3) For professional commercial use, log hours of operation to determine proper maintenance intervals

2) Tool kit

The tools supplied with the generator will help you to perform the owner maintenance procedures listed on the following page. Always keep this tool kit with the generator/welder.



PLUG WRENCH

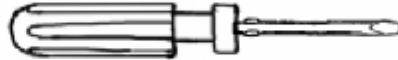

SCREW DRIVER



HANDLE BAR



TOOL BAG

3) Engine oil change

Drain the oil while the engine is warm to assure complete and rapid draining.

1. Remove the drain plug and sealing washer, oil filler cap, and drain the oil.
2. Install the drain plug and sealing washer. Tighten the plug securely.
3. Refill with the recommended oil (see page 21) and check the level.

Oil capacity: 1.1 (1:16 US qt, 0.97 Imp qt)

OIL DRAIN PLUG

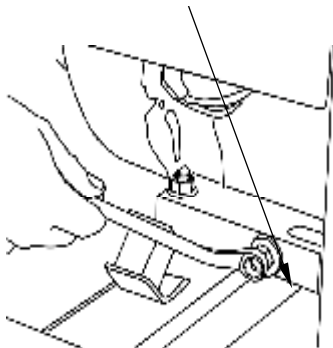

UPPER LEVER

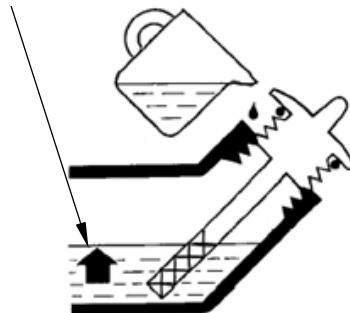

⚠ CAUTION Used motor oil may cause skin cancer if repeatedly left in contact with the skin for prolonged periods. Although this is unlikely unless you handle used oil on a daily basis, it is still advisable to thoroughly wash your hands with soap and water as soon as possible after handling used oil.

Please dispose of used motor oil in a manner that is compatible with the environment. We suggest you take it in a sealed container to your local service station or recycling center for reclamation. Do not throw it in the trash or pour it on the ground.

4) Air cleaner service

A dirty air cleaner will restrict air flow to the carburetor. To prevent carburetor malfunction, service the air cleaner regularly. Service more frequently when operating the generator/welder in extremely dusty areas.

⚠ WARNING Using gasoline or flammable solvent to clean the filter element can cause a fire or explosion. Use only soapy water or nonflammable solvent.

NOTICE Never run the generator/welder without the air cleaner. Rapid engine wear will result.

1. Unsnap the air cleaner cover clips, remove the air cleaner cover, and remove the element.
2. Wash the element in a solution of household detergent and warm water, then rinse thoroughly; or wash in nonflammable or high flash point solvent. Allow the element to dry thoroughly.
3. Soak the element in clean engine oil and squeeze out the excess oil. The engine will smoke during initial start-up if too much oil is left in the element.
4. Reinstall the air cleaner element and the cover.

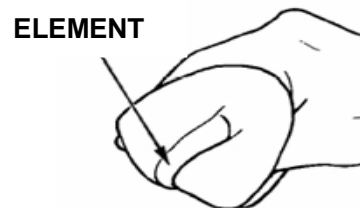
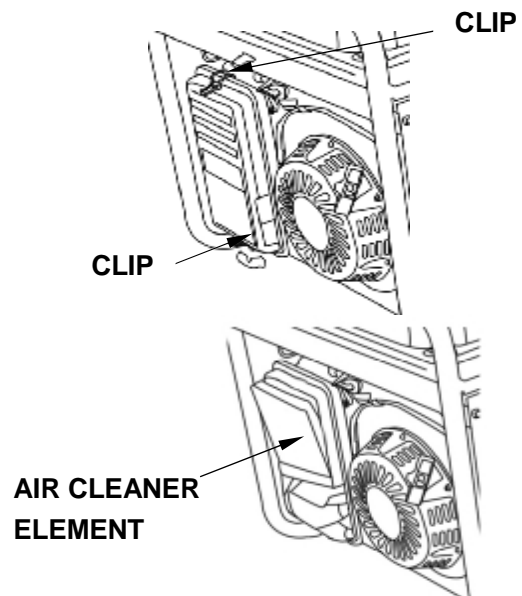

5) Fuel Sediment Cup Cleaning

The sediment cup prevents dirt or water which may be in the fuel tank from entering the carburetor. If the engine has not been run for a long time, the sediment cup should be cleaned.

1. Turn the fuel valve to the OFF position. Remove the sediment cup, O-ring, and filter.
2. Clean the sediment cup, O-ring, and filter in nonflammable or high flash point solvent.
3. Reinstall the filter, O-ring, and sediment cup.

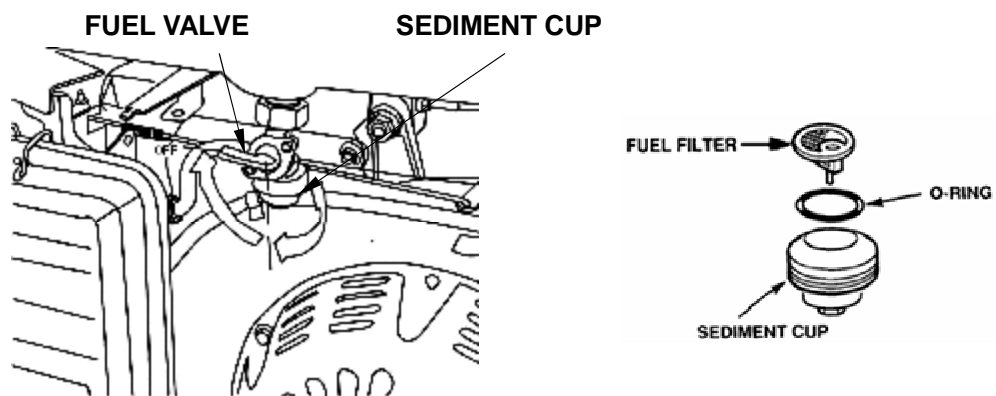

6) Spark Plug Service

Recommended spark plugs: F7RTC

To ensure proper engine operation, the spark plug must be properly gapped and free of deposits.

If the engine has been running, the muffler will be very hot. Be careful not to touch the muffler.

1. Remove the spark plug cap.
2. Clean any dirt from around the spark plug base.
3. Use the wrench supplied in the tool kit to remove the spark plug.

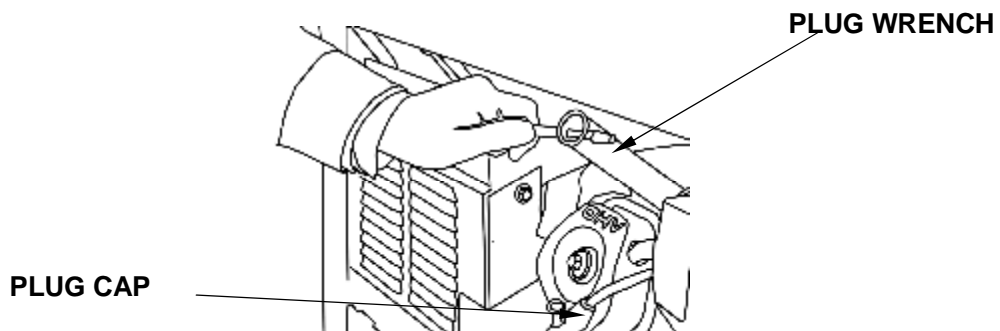

-
4. Visually inspect the spark plug. Discard it if the insulator is cracked or chipped. Clean the spark plug with a wire brush if it is to be reused.
 5. Measure the plug gap with a feeler gauge.
Correct as necessary by carefully bending the side electrode.
- The gap should be:** 0.70-0.80 mm (0.028-0.031 in).

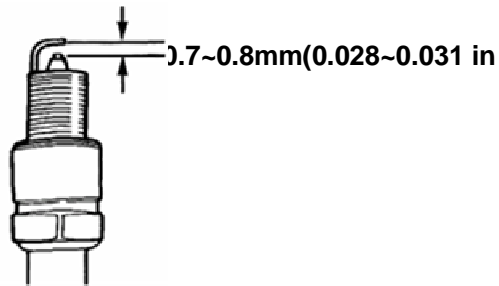

6. Check that the spark plug washer is in good condition, and thread the spark plug in by hand to prevent cross-threading.
7. After the spark plug is seated, tighten with a spark plug wrench to compress the washer.
*If installing a new spark plug, tighten 1/2 turn after the spark plug seats to compress the washer. If reinstalling a used spark plug, tighten 1/8 - 1/4 turn after the spark plug seats to compress the washer.

NOTICE The spark plug must be securely tightened. An improperly tightened spark plug can become very hot and could damage the engine. Never use spark plugs which have an improper heat range. Use only the recommended spark plugs or equivalent.

8. TRANSPORTING/STORAGE

When transporting the generator/welder, turn the engine switch and the fuel valve OFF and keep the generator/welder level to prevent fuel spillage. Fuel vapor or spilled fuel may ignite.

WARNING Contact with a hot engine or exhaust system can cause serious burns or fires. Let the engine cool before transporting or storing the generator/welder.

Take care not to drop or strike the generator/welder when transporting. Do not place heavy objects on the generator/welder.

Before storing the unit for an extended period:

1. Be sure the storage area is free of excessive humidity and dust.

2. Service according to the table below:

STORAGE TIME	RECOMMENDED SERVICE PROCEDURE TO PREVENT HARD STARTING
Less than 1 month	No preparation required
1 to 2 months	Fill with fresh gasoline and add gasoline Conditioner *.
2 months to 1 year	Fill with fresh gasoline and add gasoline Conditioner *. Drain the carburetor float bowl . Drain the fuel sediment cup .
1 year or more	Fill with fresh gasoline and add gasoline Conditioner *. Drain the carburetor float bowl . Drain the fuel sediment cup . Remove the spark plug. Put a tablespoon of engine oil into the cylinder. Turn the engine slowly with the pull rope to distribute the oil. Reinstall the spark plug. Change the engine oil . After removal from storage, drain the stored gasoline into a suitable container, and fill with fresh gasoline before starting.
*Use gasoline conditioners that are formulated to extend storage life. Contact your authorized generator dealer for conditioner recommendations.	

1. Drain the carburetor by loosening the drain screw. Drain the gasoline into a suitable container.

⚠ WARNING

Gasoline is extremely flammable and is explosive under certain conditions. Perform this task in a well ventilated area with the engine stopped. Do not smoke or allow flames or sparks in the area during this procedure.

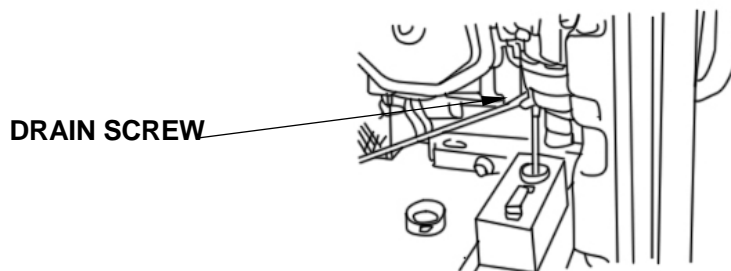

-
2. Change the engine oil.
 3. Remove the spark plug, and pour about a tablespoon of clean engine oil into the cylinder. Crank the engine several revolutions to distribute the oil, then reinstall the spark plug.
 4. Slowly pull the starter grip until resistance is felt. At this point, the piston is coming up on its compression stroke and both the intake and exhaust valves are closed. Storing the engine in this position will help to protect it from internal corrosion.

Align the notch on the starter pulley with the hole at the top of recoil starter.

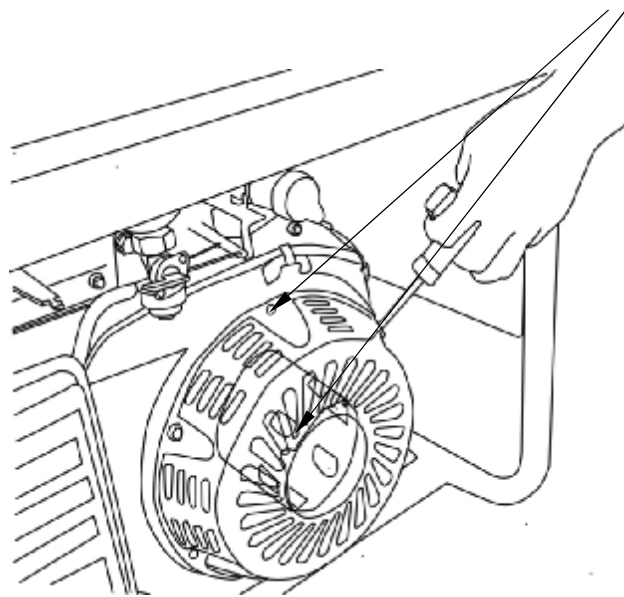

9.TROUBLESHOOTING

When the engine will not start:

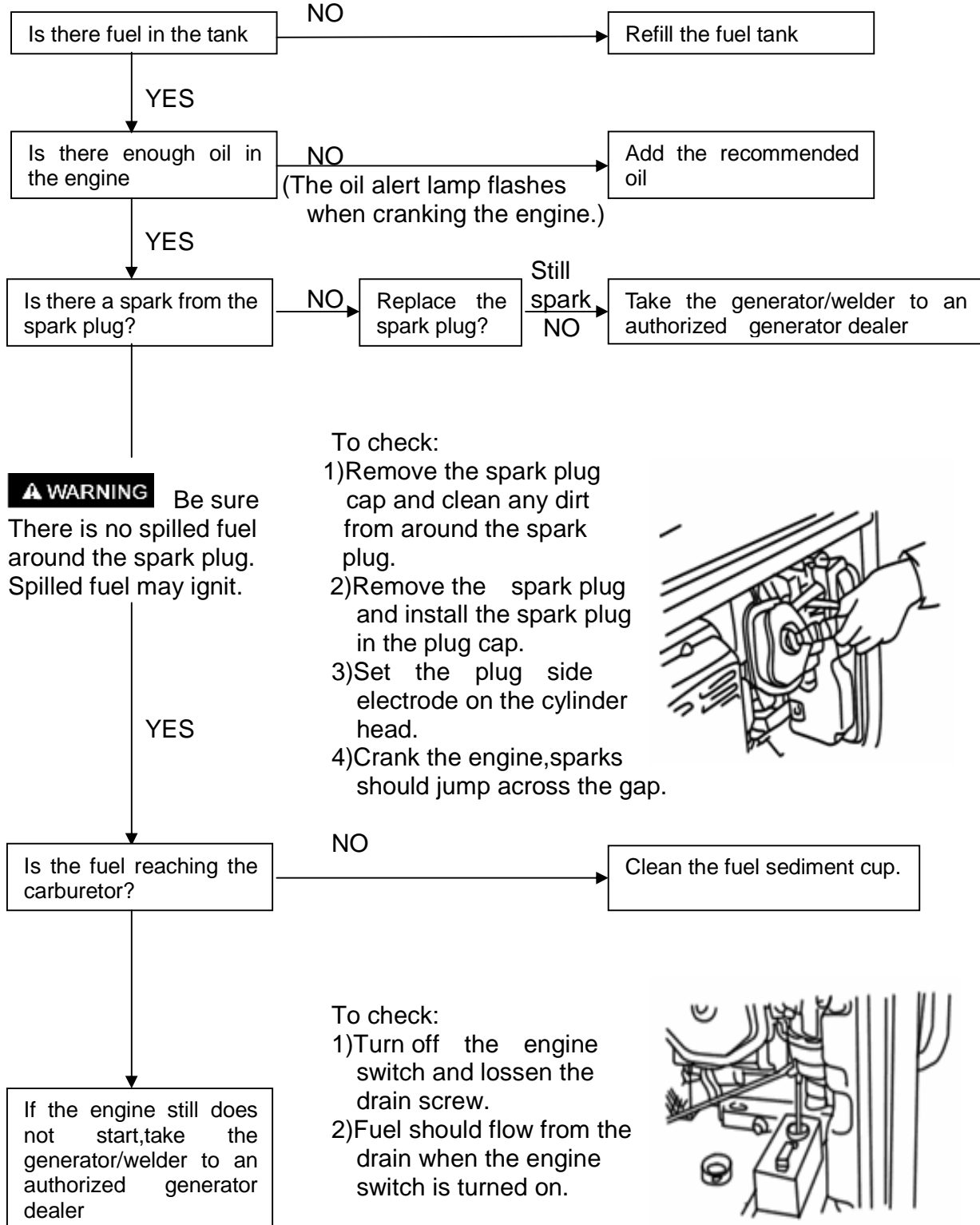

NO electricity at the AC receptacles:

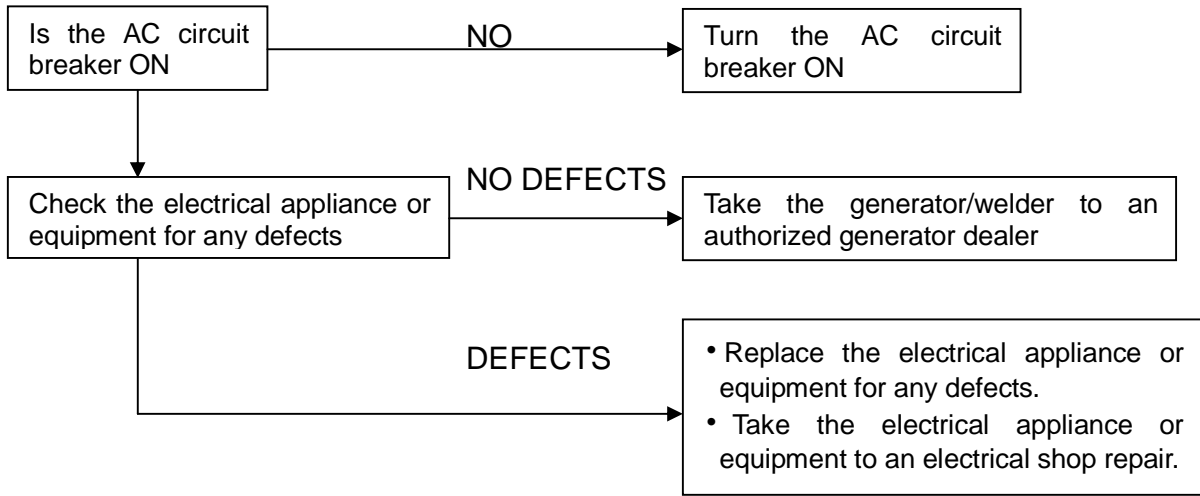

When the welding arc is weak:

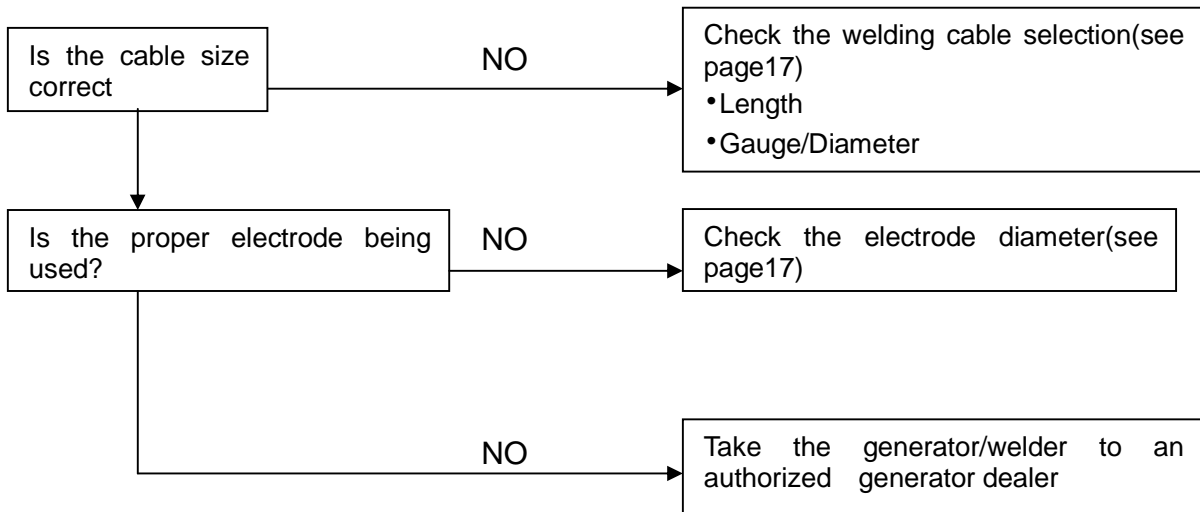

10.SPECIFICATIONS

Item	Type	W190	W190D
Generator	Generator Type	Synchronous Generator	
	Phase	Single	
	Rated Output(kW)	2	
	Max. Output(kW)	2.2	
	Rated Voltage AC(V)	220	
	Rated Frequency(Hz)	50/60	
	Duty	S1	
	Insulation Class	F	
Welding	Rated Output(kW)	3.64	
	Rated Frequency(Hz)	60	
	Rated Current(A)	140	
	range of Current Adjust(A)	50-190	
	Rated Voltage DC(V)	26	
	Duty S2	10 min	
	Dia. Of Welding Rod(mm)	2.6-5.0	
Engine	Engine Model	188FW	188FWD
	Bore & Stroke(mm x mm)	88 X 64	
	Displacement(cm ³)	389	
	Compression Ratio	8.0:1	
	Max. Output(kW/rpm)	9	
	Rated Output(kW/rpm)	8.3	
	Max. Torque(N.m/rpm)	26.5/2500	
	Igniting Model	T.C.I	
	Starting Model	Hand	Hand/Electric
	Oil Volume(L)	1.1	
	Min.Fuel Consumption(g/dW.h)	2.7	
	Air Cleaner	Half-Dry, Oil Immersed, Foam Filer Element	
	Engine Type	OHV, Tilt, Single Cylinder, Forced Air Cooling,4-Stroke	
Generator set	Standard Collocate	Large Size Air Cleaner, Large Size Fuel Muffler, Large Size Fuel Tank, Voltmeter, Non-fuse Breaker	
	Protect Class	IP21	
	Fuel Volume(L)	25	
	Continuum Run Time(h)	9	
	Vibrate	Swing≤0.5mm	
	L X W X H	679X511X490	
	Net Weight(kg)	88	92

11.WELDING WIRING DIAGRAM

1) 50Hz W190D

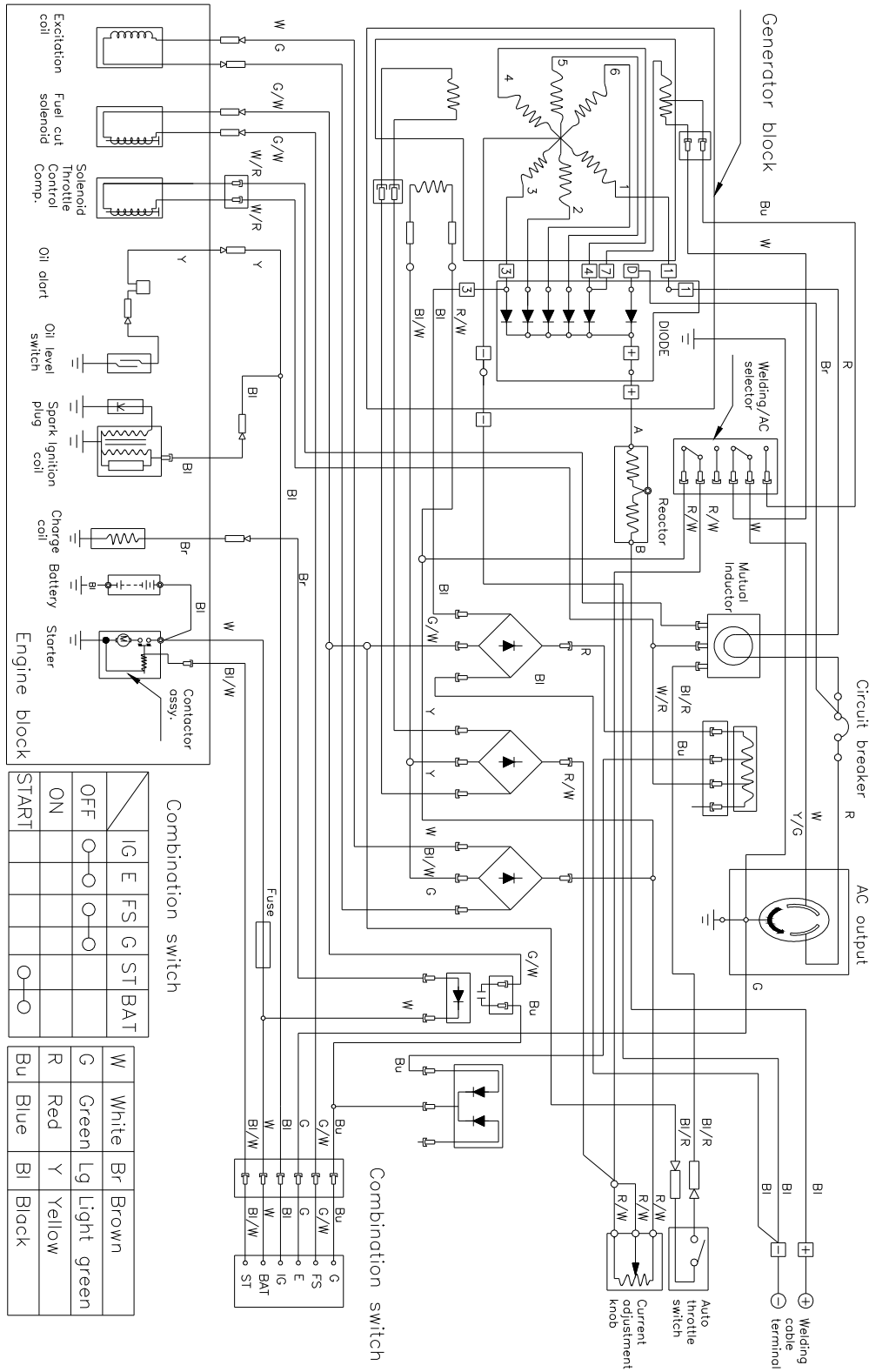

Combination switch

START	ON	OFF	IG	E	FS	G	ST	BAT
	○	○	○	○	○	○	○	○

W	White	Br	Brown
G	Green	Lg	Light green
R	Red	Y	Yellow
Bu	Blue	Bl	Black

2) 50Hz W190

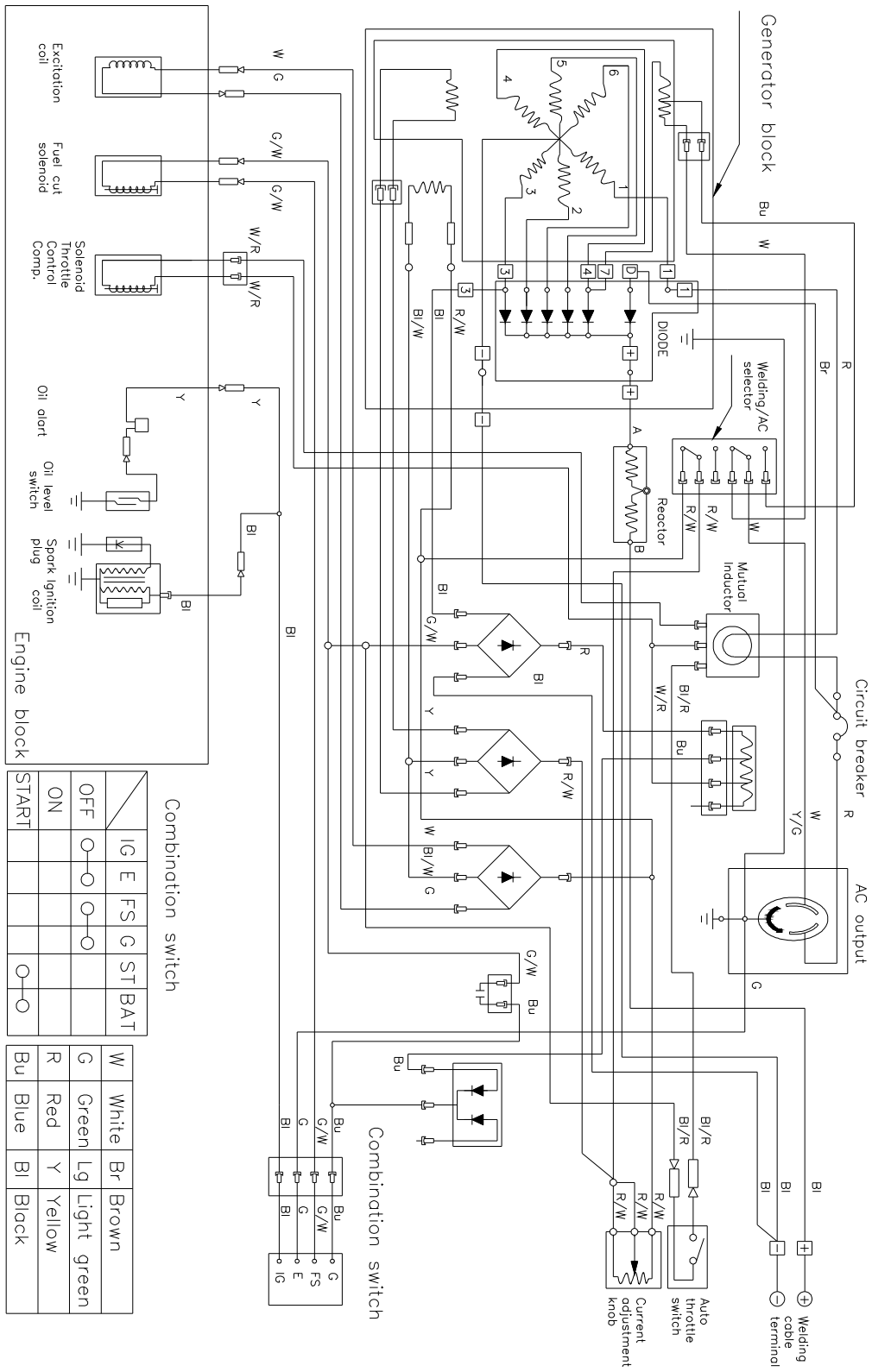

Combination switch

	IG	E	FS	G	ST	BAT
OFF	○	○	○	○		
ON						
START						

W	White	Br	Brown
G	Green	Lg	Light green
R	Red	Y	Yellow
Bu	Blue	BI	Black

3) 60Hz W190D

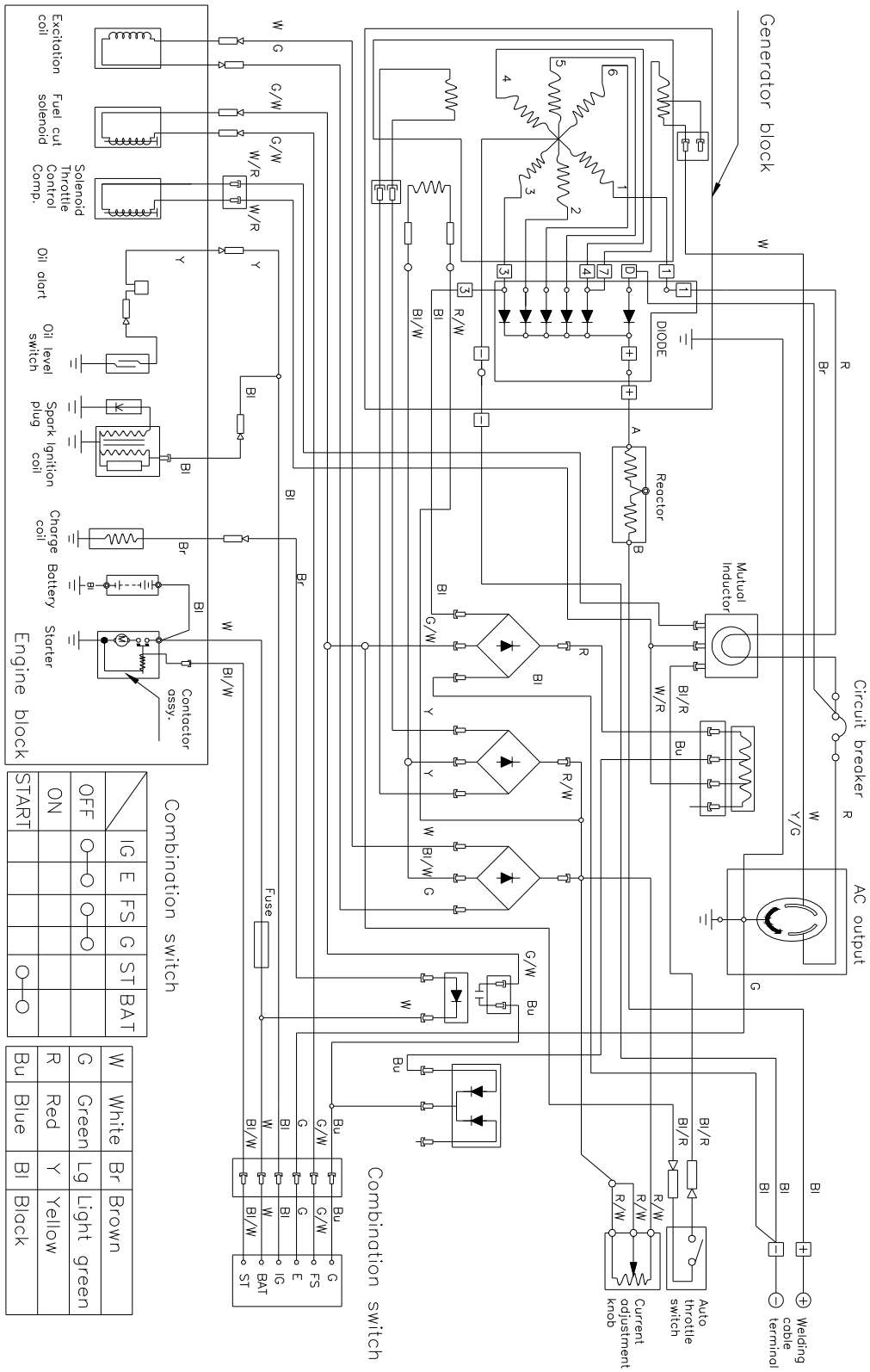

4) 60Hz W190

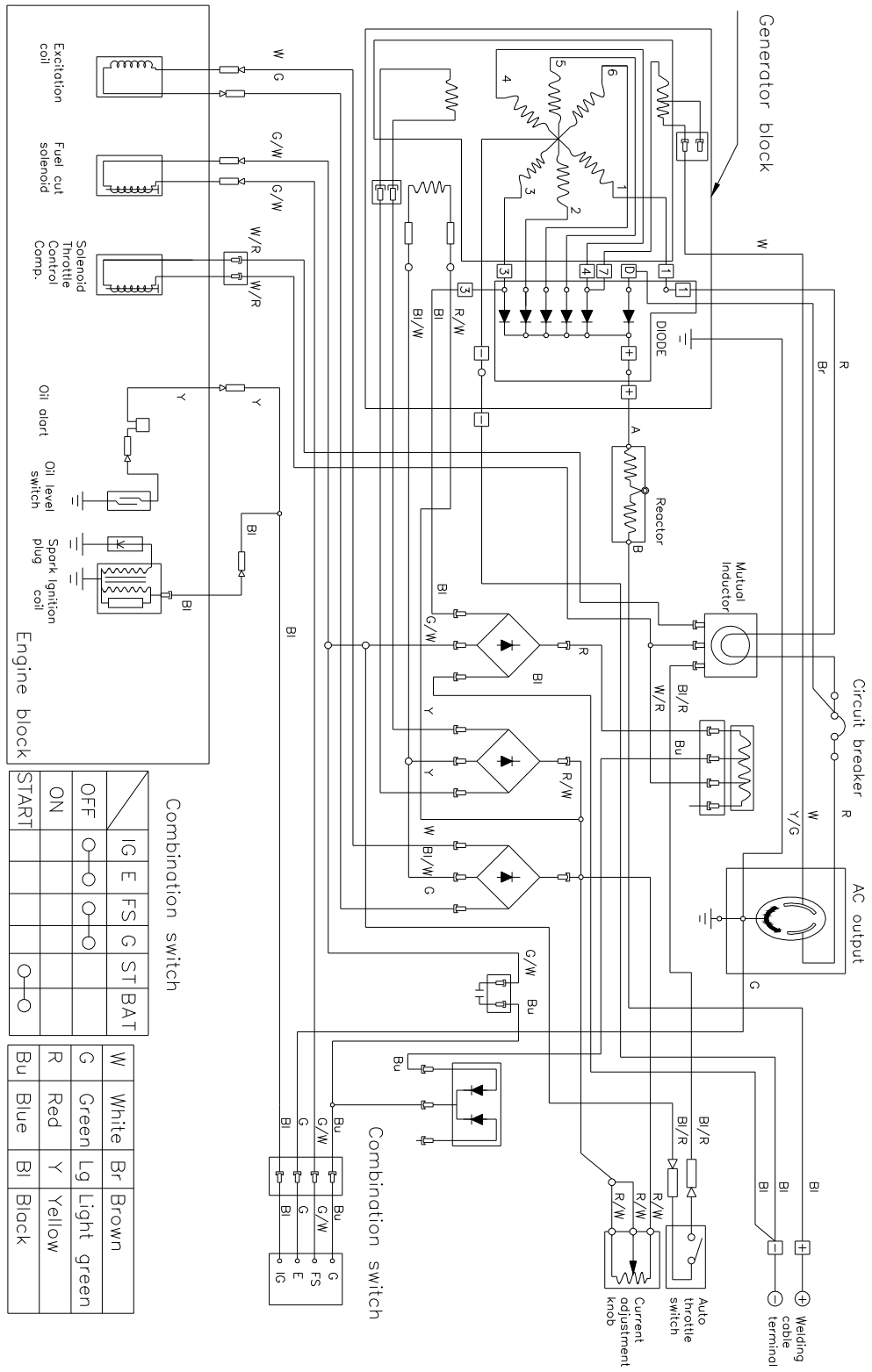

12.OPTIONAL PARTS

1) BATTERY

Use a battery rated at 12V, 35AH or more.

NOTICE Do not reverse polarity. Serious damage to the generator and/or battery may occur.

WARNING A battery can explode if you do not follow the seriously injuring anyone nearby.

Keep all sparks, open flames, and smoking materials away from the battery.

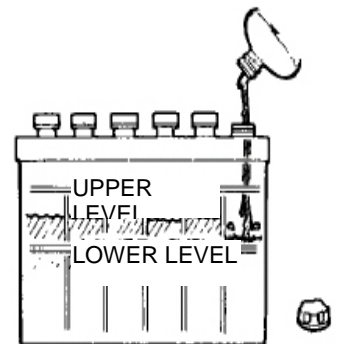

Check the electrolyte level to be sure that it is between the marks on the case. If the level is below the lower mark, remove the caps and add distilled water to bring the electrolyte level to the upper mark. The cells should be equally full.

Battery Tray Kit

- ①. Install the battery guard on the frame.
Set the battery tray on the battery guard and tighten the bolts.
- ②. Route the starter cable under the tank and connect it to the starter solenoid.

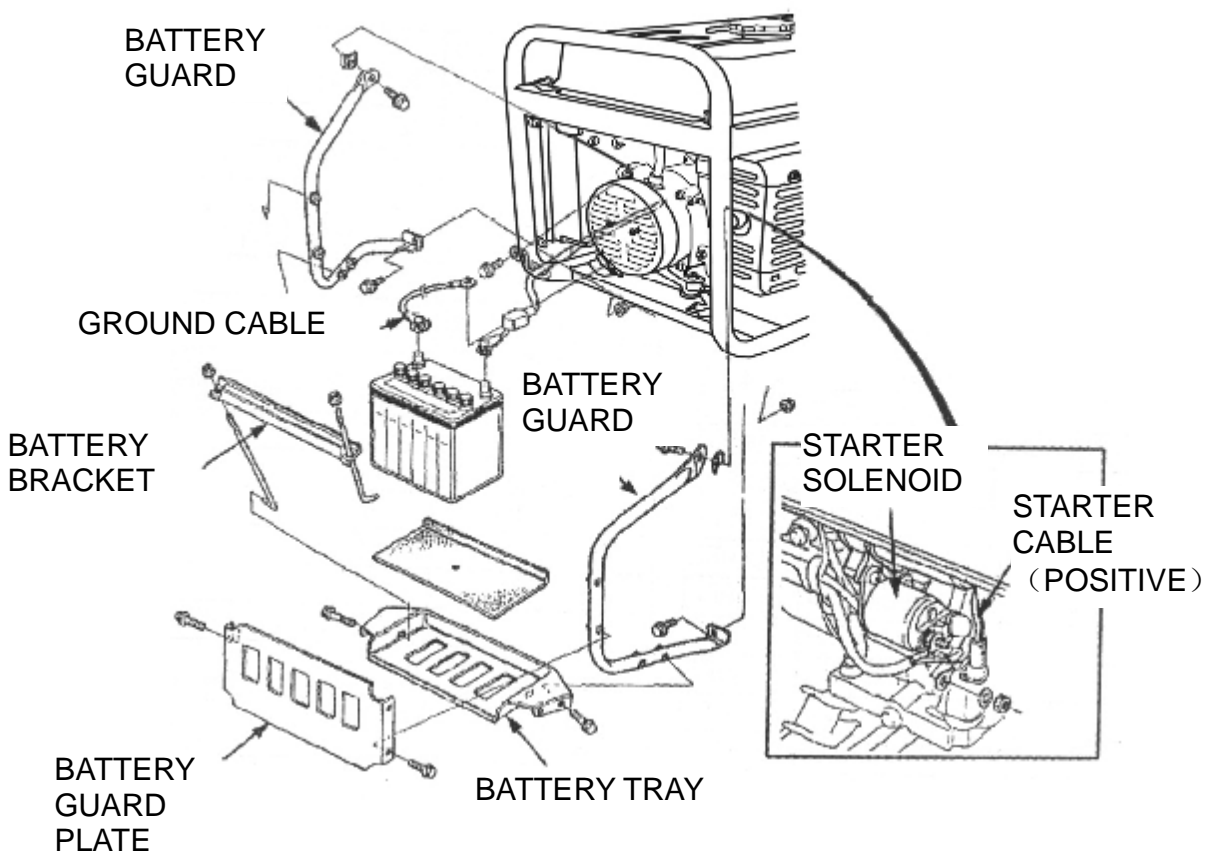

-
- ③. Connect the ground cable to the generator rear housing.
 - ④. Set the battery on the battery tray and secure with the battery bracket.
Connect the starter cable to the battery positive (+) terminal first, then to the negative (-) terminal. When disconnecting, disconnect at the battery negative (-) terminal first.
 - ⑤. Install the battery guard plate on the battery guard.

2) 4- Wheel Kit Installation

1. Install the four wheels on the axle shaft.
2. Install the axle assembly on the generator using four bolts and nuts.

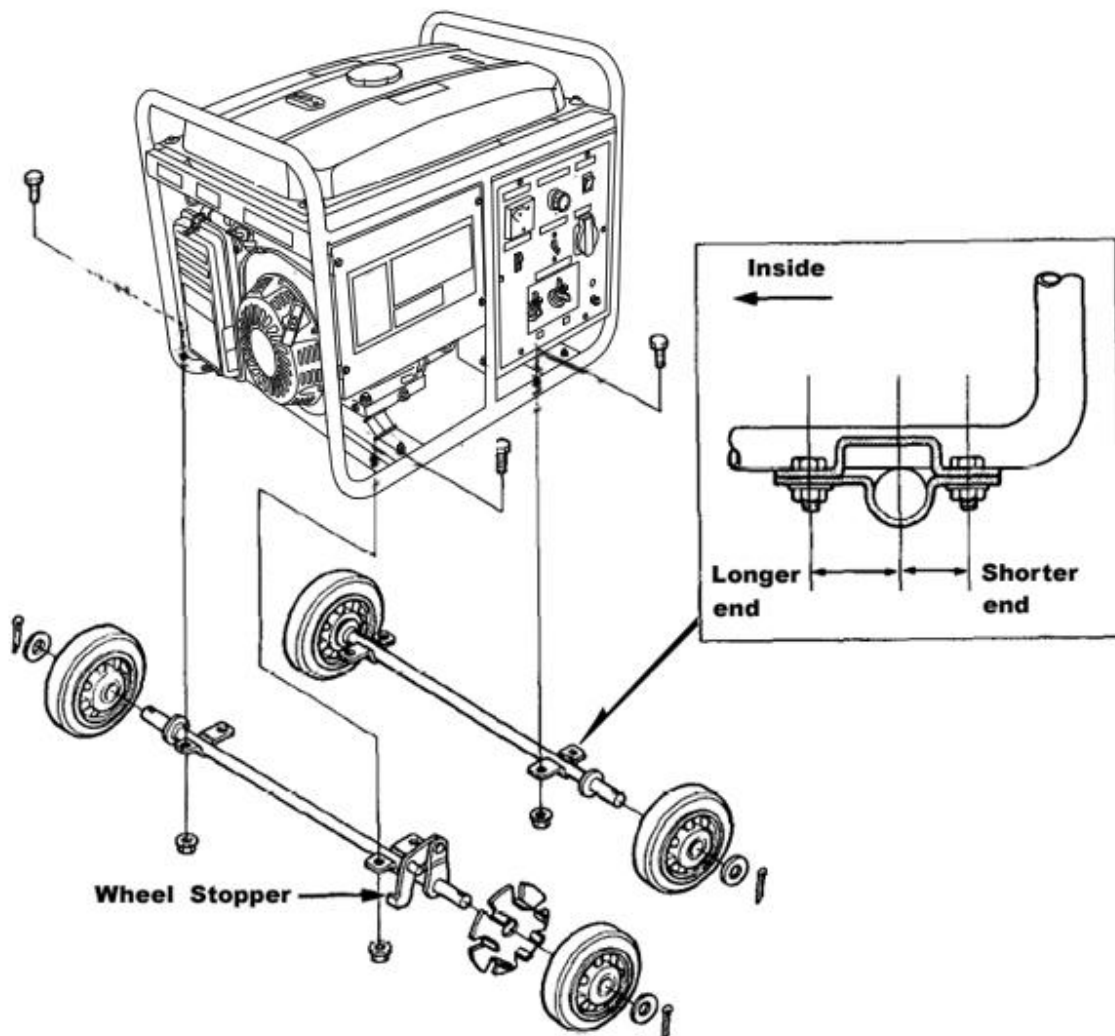

NOTE: Install the shaft with the wheel stopper facing the engine side.



Loncin motor co., Ltd.

Add: No. 99 Hualong Road, Jiulongpo District, Chongqing, China

Tel: 86 23 8980 5678 / 86 23 8980 8505

Fax: 86 23 8906 7566

Email: marketing@loncinengine.com

Website: www.loncinengine.com

PRINTED IN CHINA