

**LONCIN** 隆鑫

**General Power Products**

## **Gasoline Generator**

**LC2500-J**

**LC6500-J**

## **Owner's Manual**



Thank you for purchasing our generator set (hereinafter referred to as a generator).  
The copyright of the Manual is reserved to our company.

No part of this publication may be reproduced, transmitted, distributed or stored without prior written permission of our company.

Our company's English name and its Chinese translation are the brand or registered trademark of our company.

Our company adheres to a strategy of sustainable development, so we reserve the right to make changes or improvements without notice to any product described in this publication.

This manual should be considered a permanent part of the generator and should remain with it if it is resold.

This manual contains the information about how to use the generator correctly, please read it carefully before operating the generator. Safe and correct operation of the generator will give you the best results.

## Safety Warnings

**⚠ DANGER** Personal safety and property safety of you and others are very important. We have provided three kinds of safety messages in this manual and on the generator labels. Each safety message is preceded by a symbol . Please read these messages carefully.

You WILL be SERIOUSLY HURT if you don't follow instructions.

**⚠ WARNING** You CAN be SERIOUSLY HURT if you don't follow instructions.

**⚠ CAUTION** You CAN be HURT if you don't follow instructions.

**NOTICE** Your generator or other property could be damaged if you don't follow instructions.

# CONTENTS

1. SAFETY INSTRUCTIONS.....	1
2. COMPONENT IDENTIFICATION.....	3
3. CONTROLS.....	4
1) Engine Switch.....	4
2) Recoil Starter.....	4
3) Fuel Cock.....	4
4) Choke Lever.....	5
5) Overcurrent Protector.....	5
6) Ground Terminal.....	6
7) Oil Alert System.....	6
4. GENERATOR USE.....	7
1) Connections to a Home Power Supply.....	7
2) Generator Ground Circuit.....	8
3) AC Applications.....	8
4) DC Applications.....	9
5) High Altitude Operation.....	10
5. PREOPERATION CHECK.....	11
1) Engine Oil.....	11
2) Fuel.....	11
6. STARTING THE ENGINE.....	13
7. STOPPING THE ENGINE.....	13
8. MAINTENANCE.....	14
1) Engine Oil Change.....	15
2) Air Filter Service.....	15
3) Fuel Sediment Cup.....	16
4) Spark Plug.....	16
9. STORAGE.....	18
10. TROUBLESHOOTING.....	19
11. WIRING DIAGRAM.....	20
12. Parameters.....	22

# SAFETY INSTRUCTIONS

## 1. SAFETY INSTRUCTIONS

Read and understand this owner's manual before operating your generator. It will help you avoid accidents if you get familiar with your generator's safe operation procedures.

**Never use it indoors**



**Never use it in a wet condition**

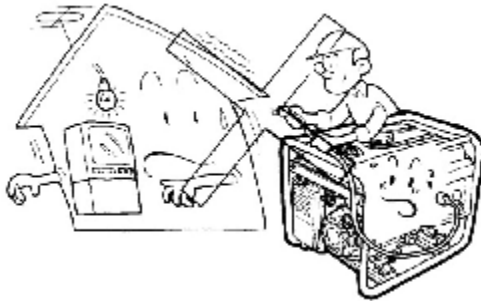

**Never directly connect it to a home power system**

**Keep it at least 1m away from Inflammables**

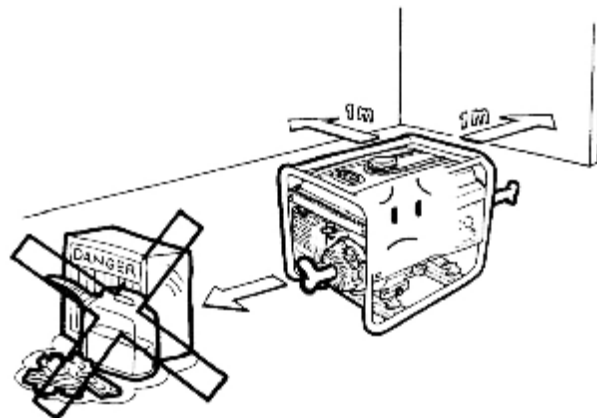

# SAFETY INSTRUCTIONS

---



**Never smoke when fueling**

**Don't spill when fueling**

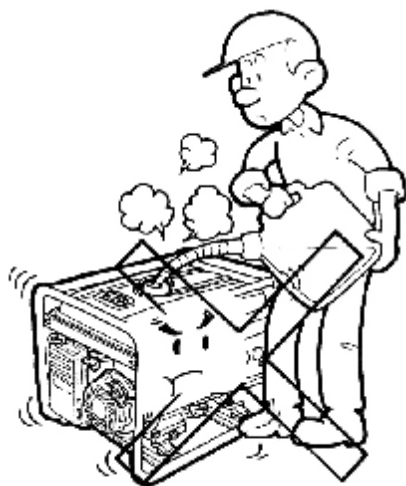
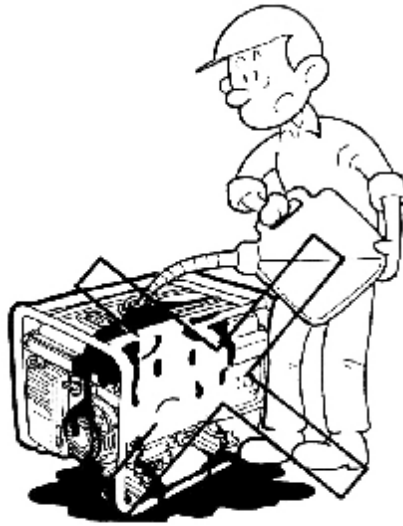

**Stop the engine before fueling**

# COMPONENT IDENTIFICATION

## 2. COMPONENT IDENTIFICATION

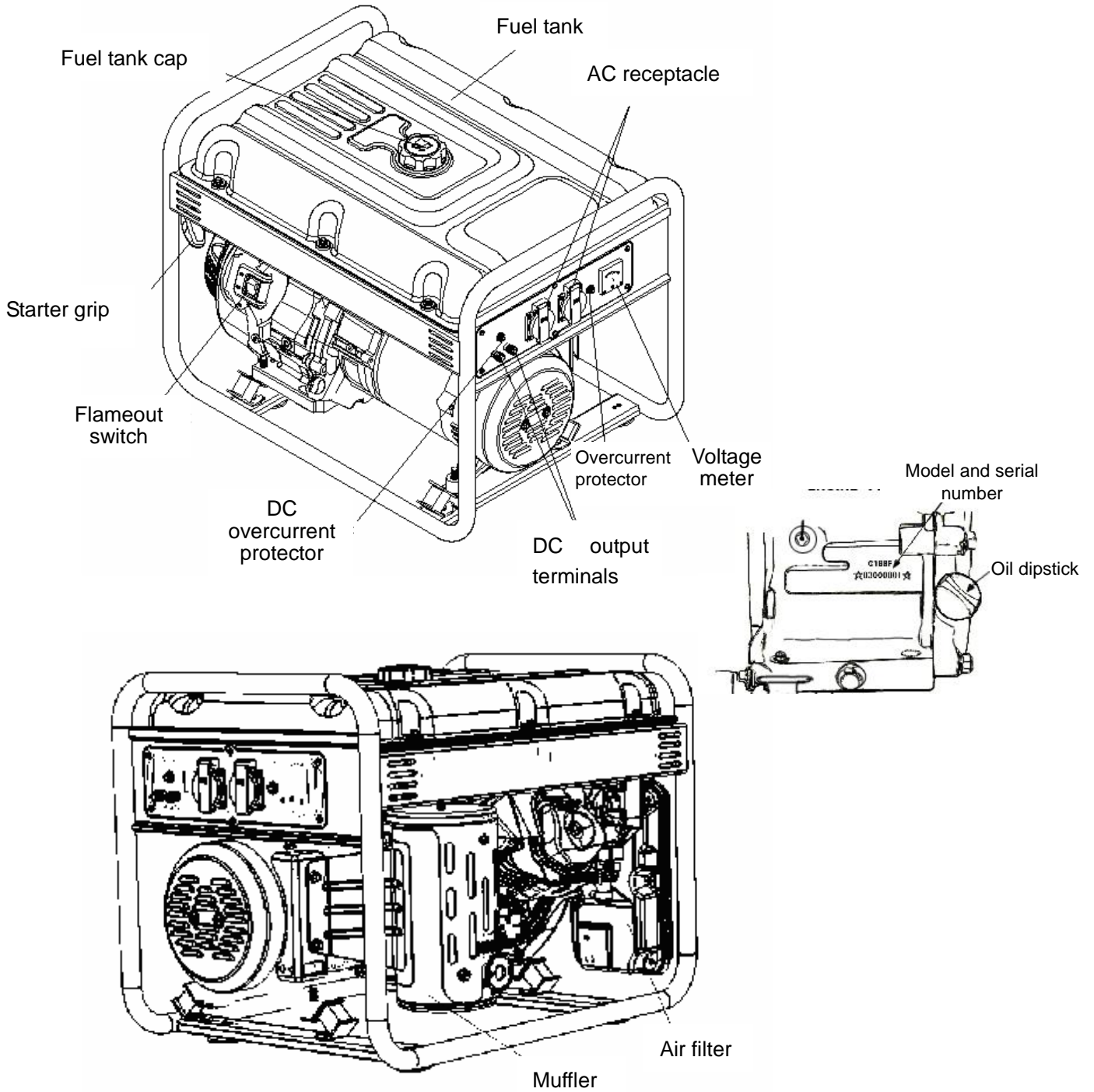

# CONTROLS

## 3. CONTROLS

### 1) Engine Switch

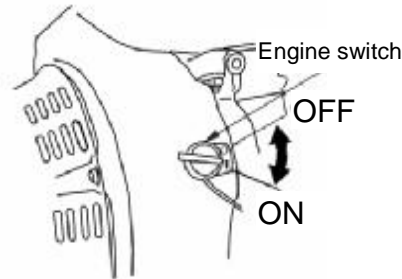

LC2500-J Start switch

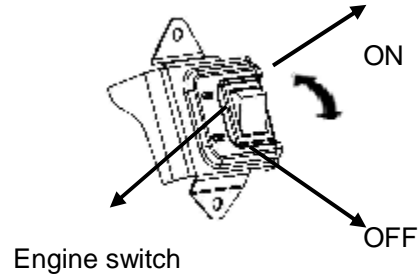

LC6500-J Start switch

### 2) Recoil Starter

Gently pull up the starter grip and pull it out briskly when a resistance is felt.

#### NOTICE

Don't let the starter grip spring back abruptly after starting; the starter grip should be let back gently.

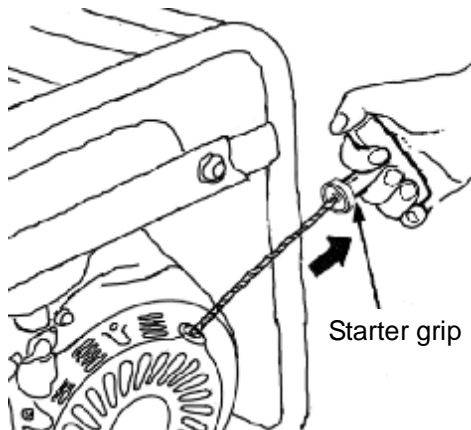

### 3) Fuel Cock

Fuel cock is for controlling fuel flow from fuel tank to the carburetor. Ensure fuel valve is in the OFF position after stopping the engine.

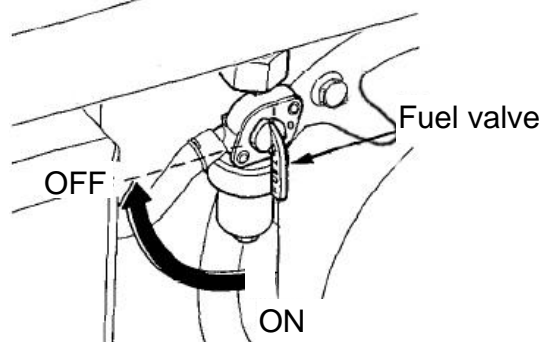

## CONTROLS

---

### 4) Choke Lever

The choke is used to provide an enriched fuel mixture when starting a cold engine. Put choke lever in the ON position when the engine has warmed up.

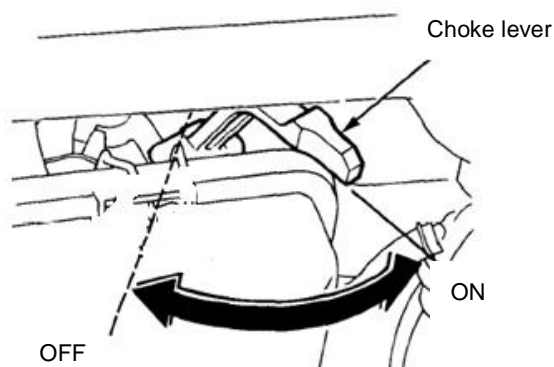

### 5) AC Overcurrent Protector

When there is a problem in the load or a wrong connection, the AC circuit will be overloaded, and the AC overcurrent protector will automatically disconnect the circuit to protect it.

When the indicator inside AC overcurrent protector pops up, it means AC overcurrent protector is in the OFF position. After several minutes, push the protector's button to let the protector back to the ON position.

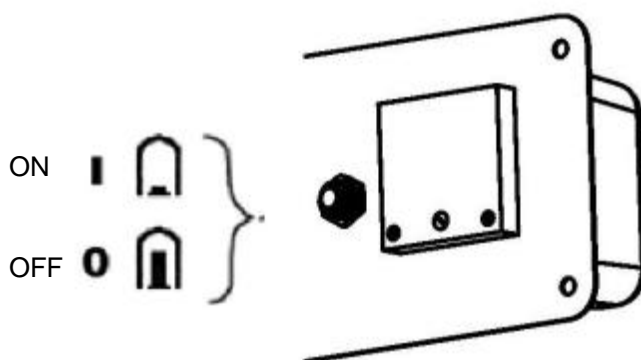

## CONTROLS

---

### 6) Ground Terminal

The ground terminal is a dedicated terminal for reliably grounding the whole generator.

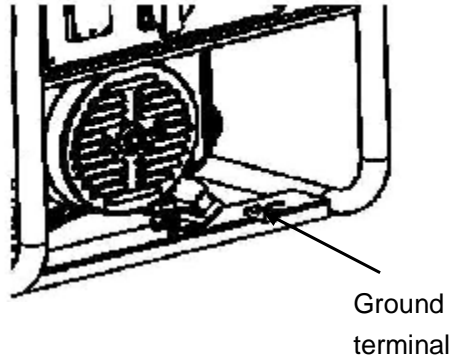

### 7) Oil Alert System

The oil alert system is designed to prevent engine damage caused by an insufficient amount of oil in the crankcase. Before the oil level in the crankcase can fall below a safe limit, the oil alert system will automatically shut down the engine (the engine switch will remain in the ON position) to avoid damage to the engine.

# GENERATOR USE

## 4. GENERATOR USE

Requirements of generator use concerning the environment

- Applicable ambient temperature range:  $-15^{\circ}\text{C}\sim 40^{\circ}\text{C}$ .
- Applicable humidity level: below 95%.
- Applicable altitude: under 3,300 feet (1,000m) above sea level; for altitudes over 3,300 feet (1,000m) above sea level, lower power rating is needed for operation).

### 1) Connections to a Home Power Supply

**NOTICE** If the generator is to be connected to a home power supply as a standby, connection shall be performed by a professional electrician or by another person with proficient electrical skill. When the loads are connected to the generator, please carefully check whether electrical connections are safe and reliable. Any improper connection may cause damage to the generator, or cause a fire.

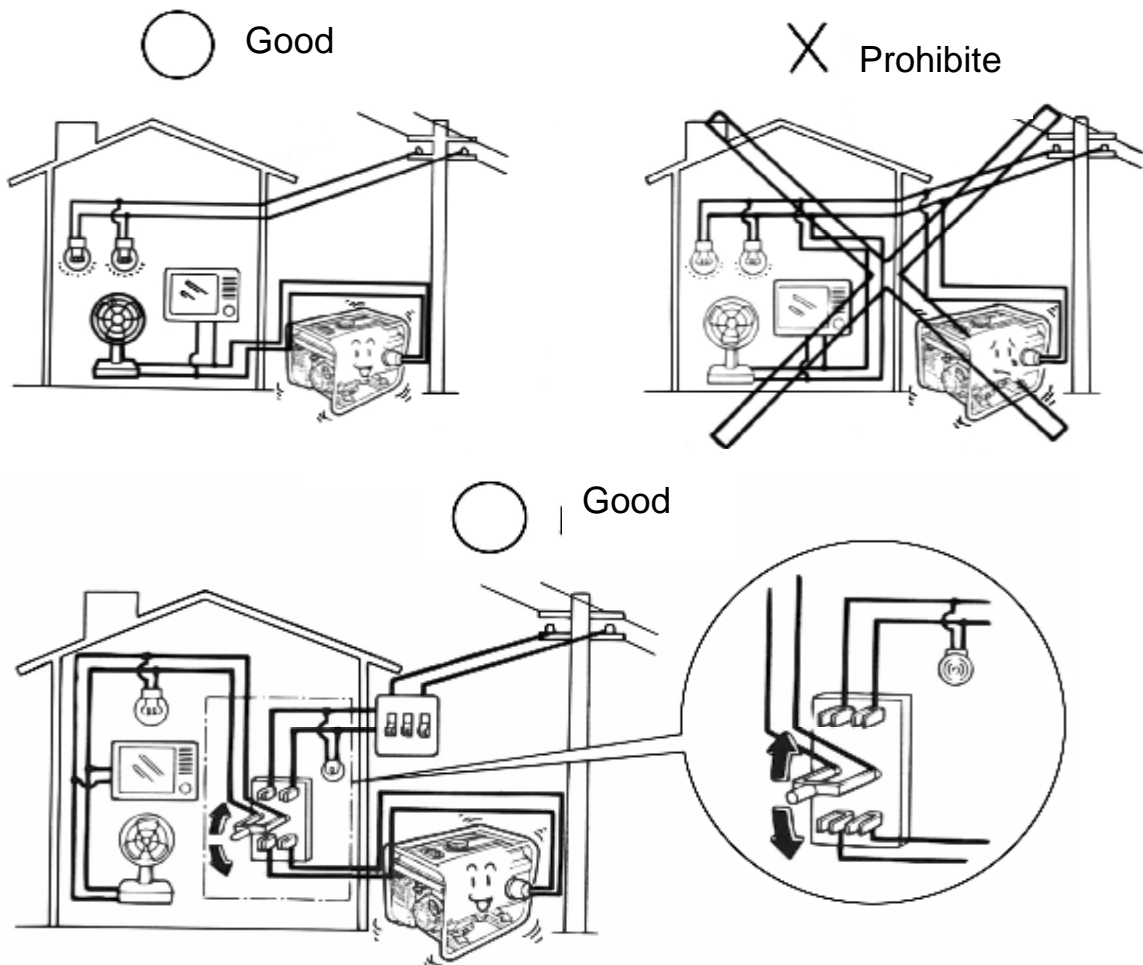

# GENERATOR USE

## 2) Generator Ground Circuit

In order to prevent electric shock due to shoddy electrical appliances or wrong use of electricity, the generator must be grounded with a good-quality insulated conductor.

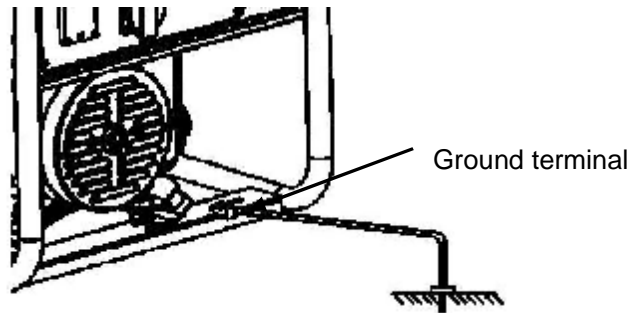

## 3) AC Applications

Before starting the generator, it must be confirmed that the total of all loads' power values doesn't exceed the generator's rated power.





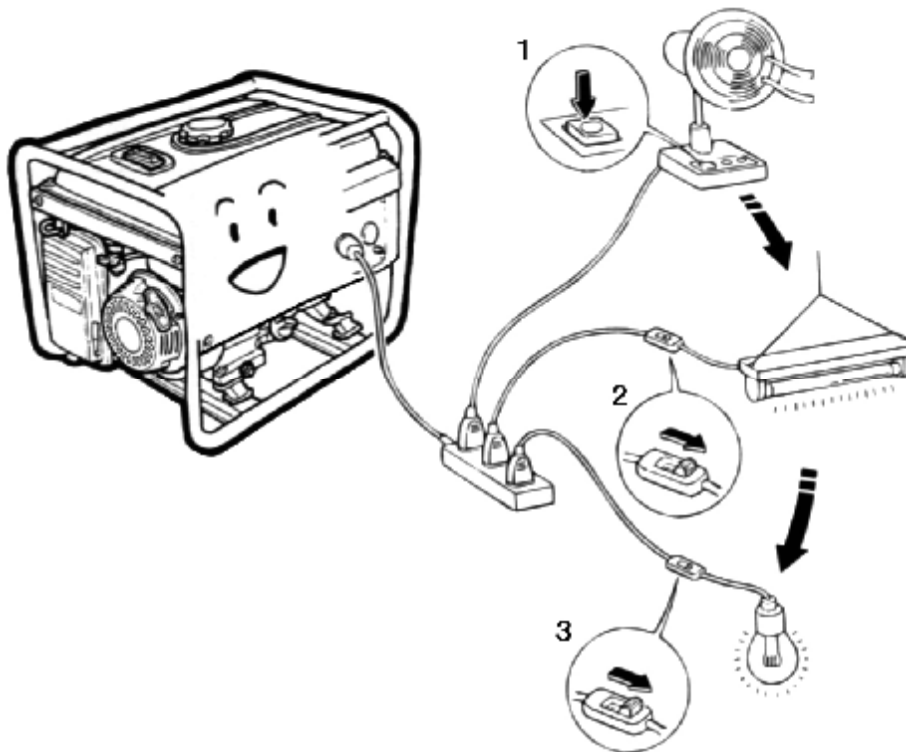

**NOTICE** Overload use will remarkably shorten the generator's service life.

If the generator is connected to multiple loads or electricity consumers, please remember to first connect the one with the highest starting current, then the one with the second highest starting current... and last connect the one with the lowest starting current.

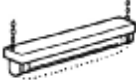

## GENERATOR USE

Generally, capacitive and inductive loads, especially motor driven devices will generate a very high starting current. The following table serves as a reference for your connecting the generator to the electricity consumers as shown in the table.

Type	Wattage		Typical device	Example		
	Starting	Rating		Device	Starting	Rating
<ul style="list-style-type: none"> <li>● Incandescent lamp</li> <li>● Heating device</li> </ul>	X1	X1	 Incandescent lamp  TV set	 Incandescent lamp 100W	100VA (W)	100VA (W)
<ul style="list-style-type: none"> <li>● Fluorescent tube</li> </ul>	X2	X1.5	 Fluorescent tube	 40W Fluorescent tube	80VA (W)	60VA (W)
<ul style="list-style-type: none"> <li>● Motor driven device</li> </ul>	X3~5	X2	 Refrigerator  Electric fan	 Refrigerator 150W	450~ 750VA (W)	300VA (W)

### 4) DC Applications

#### DC terminals

DC terminals are for supplying power to low-power DC loads, or charging other batteries. Positive DC terminals are colored red, and negative ones are colored black. Connecting loads: Connect the load's positive pole to positive DC terminal; connect the load's negative pole to negative DC terminal.

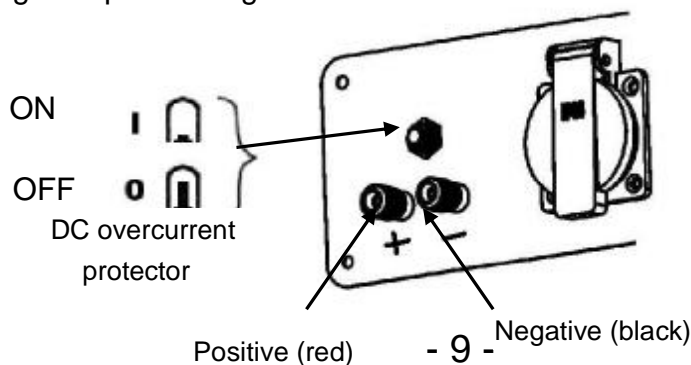

## GENERATOR USE

---

### **DC overcurrent protector**

When there is a problem in the load or a wrong connection, the DC circuit will be overloaded, and the DC overcurrent protector will automatically disconnect the circuit to protect it.

When the indicator inside DC overcurrent protector pops up, it means DC overcurrent protector is in the OFF position. After several minutes, push the DC protector's button to let it back to the ON position.

### **5) High Altitude Operation**

At high altitudes, the standard carburetor air-fuel mixture will be excessively rich. Power output will decrease, and fuel consumption will increase. High altitude performance can be improved by installing a smaller diameter main fuel jet in the carburetor and readjusting the pilot screw. If you always operate the generator at altitudes higher than 3,300 feet (1,000 meters) above sea level, have a generator dealer authorized by our company perform this carburetor modification; or the generator should be used with lowered power rating.

Even with suitable carburetor jetting, engine power will decrease approximately 3.5% for each 1,000 feet (300 meter) increase in altitude. The effect of altitude on power will be greater than this if no carburetor modification is made.

### **NOTICE**

**If an engine jetted for high altitude is used at a lower altitude, the lean air fuel mixture will reduce performance and may over-heat and seriously damage the engine.**

# GENERATOR USE

## 5. PREOPERATION CHECK

### 1) Engine Oil

**NOTICE**

Check the oil level **BEFORE EACH USE** with the generator on a level surface and with the engine stopped.

Engine oil is a major factor affecting engine performance and service life.

**Non-detergent and 2-stroke engine oils will damage the engine and are not recommended.**

Recommended engine oil  
Four-stroke gasoline engine oil  
SE or SF grade under API classification, or  
SAE10W-30 that is equivalent to SG grade.

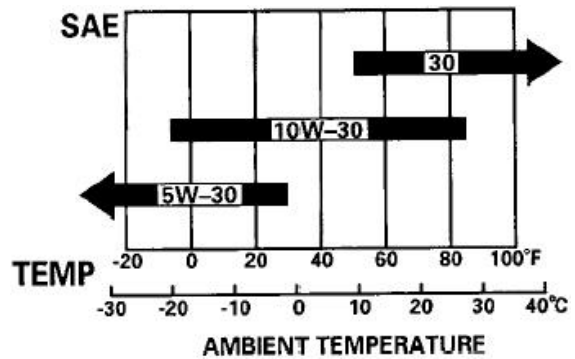

Oil check steps:

Remove the oil dipstick from the oil filler hole and wipe it clean; Insert the dipstick without screwing it in tight to check the engine oil level.

If the engine oil level is too low, add recommended engine oil until oil level reaches the upper limit;

After adding oil, remember to rescrew in and tighten the oil dipstick.

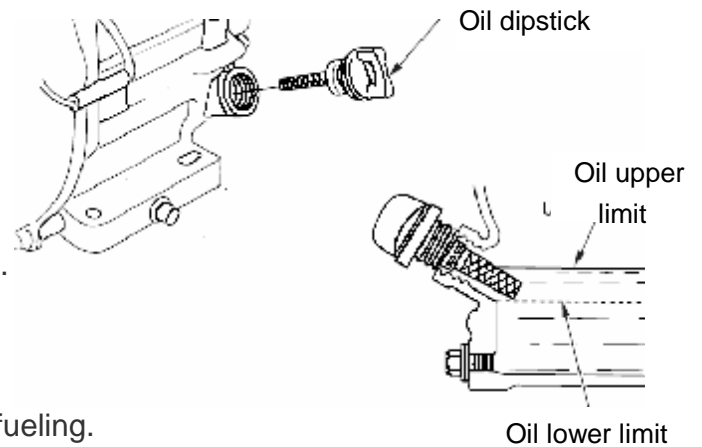

### 2) Fuel

- ①. Loosen fuel tank cap to check fuel level.
- ②. If fuel level is too low, add fuel until fuel level reaches the red mark on the top of fuel filter.
- ③. Reinstall and tighten fuel tank cap after fueling.

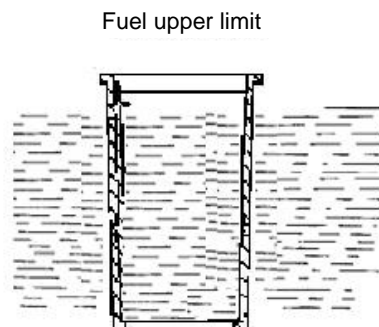
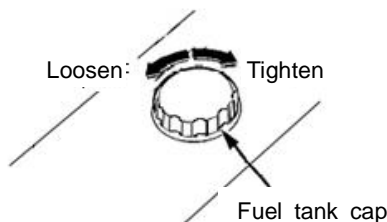

## GENERATOR USE

---

### **⚠ WARNING**

- **Fuelling must be performed in a place with good ventilation when the engine has stopped. Remember: never smoke or light a fire.**
- **Never spill the fuel out when fueling**
- **Avoid long or frequent contact with fuel or inhalation of fuel vapor.**
- **Never let children contact fuel.**
- **Never use oil-fuel mixture or gasoline with impurities.**

The gasoline's octane value should be 90 or higher.

Unleaded gasoline is recommended by us because it produces less carbon deposit on the engine and spark plug, and can prolong service life of the exhaust system.

Never use long aged gasoline, contaminated gasoline or gasoline mixed with engine oil. Never let dust or water into the fuel tank.

## STARTING/STOPPING THE ENGINE

---

### 6. STARTING THE ENGINE

#### 1) Manual starting

- ①. Cut off all loads from the output end.
- ②. Turn the fuel cock to the ON position.
- ③. Put the choke lever in the OFF position.

**NOTICE**

Do not shut off the choke if the engine is started when it is warm.

- ④. Put the engine switch in the ON position.
- ⑤. Gently pull up the starter grip and pull it out briskly when a resistance is felt.
- ⑥. When the engine has warmed up, put the choke lever in the ON position.

### 7. STOPPING THE ENGINE

- ①. Turn off engine switch.
- ②. Turn off fuel cock.

**NOTICE**

If an emergency stop of the engine is needed, the engine switch should be put in the OFF position.

# MAINTENANCE

---

## 8. MAINTENANCE

Good maintenance is the best assurance for safe, economical and zero-malfunction running of the generator, and it is also good for environment protection.

**▲ WARNING** Engine exhaust gas contains poisonous carbon monoxide. Maintenance can only be performed after the engine is stopped. If maintenance must be performed while the engine is running, the working area must be well ventilated.

Periodic maintenance and adjustment are necessary for keeping the generator in a good operating condition. Maintenance schedule is as follows:

MAINTENANCE SCHEDULE		Each use	Firs month or 20 Hrs (3)	Every 3 months or 50 Hrs (3)	Every 6 months or 100 Hrs (3)	Every year or 300 Hrs (3)
Engine oil	Check oil level	○				
	Change		○		○	
Air filter	Check	○				
	Clean			○ (1)		
Fuel sediment cup	Clean				○	
Battery electrolyte level	Check	○				
Spark plug	Clean				○	Replace
Valve clearance	Readjust					○ (2)
Cylinder head	Clean	Every 300 Hrs. (2)				
Fuel tank and strainer	Clean	Every two years(2)				
Fuel line	Replace	Every two years(2)				

- (1) Maintain more frequently when the generator is used in dusty areas.
- (2) These items should be maintained by an authorized dealer of our company.
- (3) If the generator is to be used frequently, maintenance shall be performed as per the schedule above to ensure long-time normal operation.

## MAINTENANCE

### **▲ WARNING**

Improper maintenance, or failure to correct a problem before operation, can cause a malfunction by which you can be hurt or killed.

Always follow the inspection and maintenance recommendations and schedules in this owner's manual.

### 1) Engine oil change

Drain the engine oil when the engine has been warmed to ensure complete and rapid draining.

- ①. Remove the oil dipstick and screw off the drain plug to drain the engine oil
- ②. Reinstall the oil drain plug and tighten it.
- ③. Refill with the recommended engine oil and check oil level.

Engine oil volume:

168F-II: 0.6L

188F: 1.1L

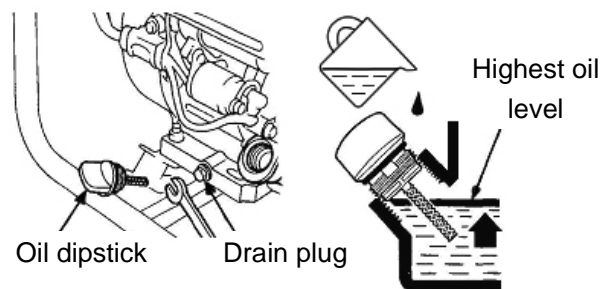

### **▲ CAUTION**

Engine oil may cause skin cancer if repeatedly left in contact with the skin for prolonged periods. Although the skin cancer does not necessarily happen, it is still advisable to thoroughly wash the skin that has contacted engine oil with soap and water after handling engine oil.

For the sake of environment protection, please treat the used engine oil in an appropriate way. We strongly advise you to store the used engine oil in a sealed container and take it to the local service station or recycling center for used oil reclamation. Never throw it in the trash or pour it on the ground or into the ditch.

### 2) Air filter maintenance

A dirty air filter will restrict air flow into the carburetor. To prevent carburetor malfunction, maintain the air filter regularly. Maintain it more frequently when operating the generator in extremely dusty areas.

### **▲ WARNING**

Using gasoline or inflammable solvent to clean the filter element can cause a fire or explosion. Use only soapy water or nonflammable solvent.

### **NOTICE**

Never run the generator without the air filter, or rapid engine wear will result.

## MAINTENANCE

- ①. Unsnap the air filter cover clips, remove the air filter cover and check the filter element to confirm it is complete and clean.
- ②. If the foam element is dirty, clean it following the method below:  
Wash the element in a solution of household detergent and warm water, or in a nonflammable (or high flash point) detergent, detergent; thoroughly squeeze fluid out of it. Drip some drops of engine oil into it.  
If the paper element is dirty, gently knock it several times; then use compressed air (with a pressure not higher than 207KPa) to blow it from the inside to the outside. Never use a brush to clean the paper element, or its air pores will be clogged. If the paper element is damaged, replace it with a new one

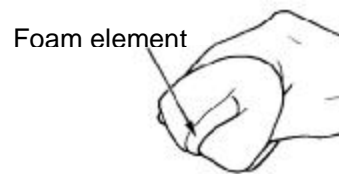
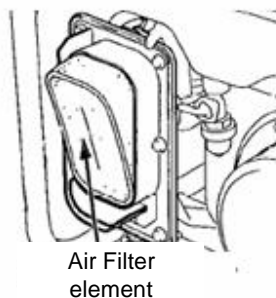
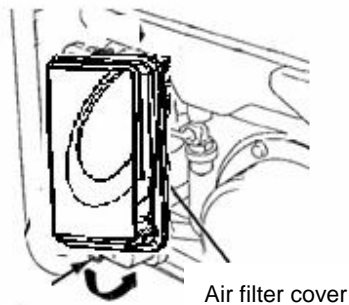

- ③. Reinstall the air filter element and the cover.

### 3) Clean the fuel sediment cup

- ①. Turn the fuel valve to the OFF position, remove the fuel sediment cup, and take out the O ring and strainer.
- ②. Clean the sediment cup, O-ring, and strainer in a nonflammable or high flash point solvent.
- ③. Reinstall O-ring and strainer, and the fuel sediment cup and tighten the cup.

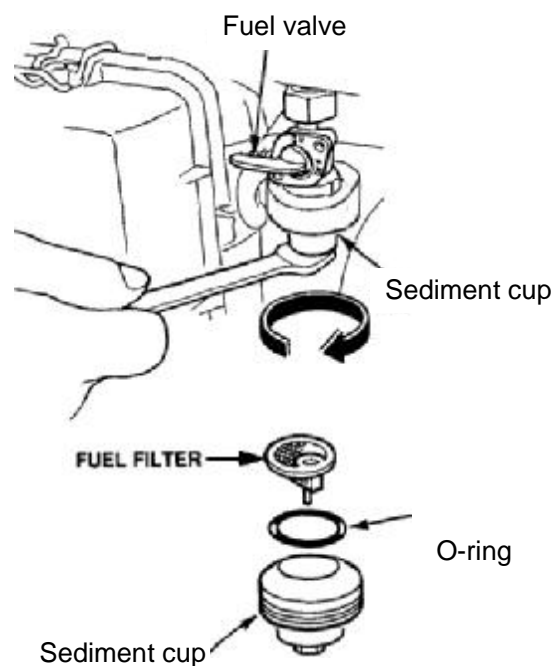

## MAINTENANCE

---

- ④. Turn the fuel valve to the ON position and check for leaks

### 4) Spark plug

Recommended spark plugs: F7RTC、F7TC

- ①. Remove the fuel tank,
- ②. Remove the spark plug cap,
- ③. Clean spark plug seat,
- ④. Use the spark plug socket wrench to remove the spark plug.

Spark plug socket wrench

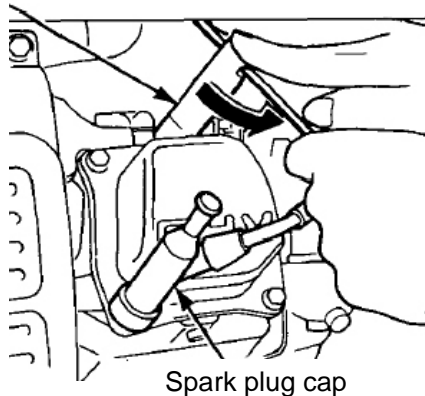

- ⑤. Visually check if the spark plug's insulation is damaged, if so, replace it with a new one.
- ⑥. Measure the plug clearance with a feeler gauge. Correct when necessary by carefully bending the side electrode. The clearance should be: 0.70-0.80mm (0.028-0.031 in).

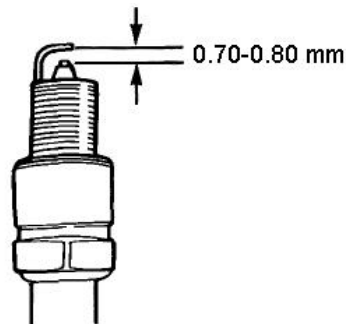

- ⑦. Check whether the spark plug washer is in a good condition.
- ⑧. Reinstall the spark plug and use the spark plug socket wrench to tighten it and tightly press the spark plug washer; then reinstall the spark plug cap.

**NOTICE**

**Use the spark plug of the appropriate heat range.**

## STORAGE

---

### 9. STORAGE

#### **⚠ WARNING**

**Contact with a hot engine part can cause a fire. Let the engine cool before transporting or storing the generator.**

If the generator is to be stored for a long period, the storage area must be kept clean and dry.

①. Drain the fuel of the fuel tank completely. Clean the fuel strainer, O-ring and sediment cup; then reinstall them. Loosen off the drain plug of the carburetor and drain off the fuel in it, then reinstall and tighten carburetor's fuel drain plug.

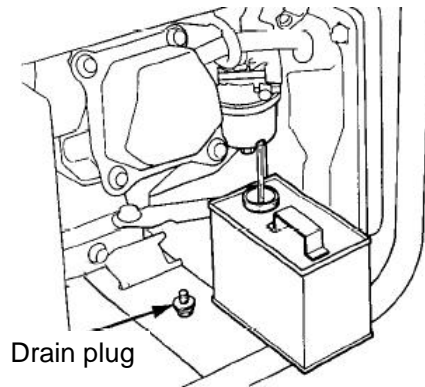

#### **⚠ WARNING**

**Gasoline is extremely flammable and is explosive under most conditions. Perform this task in a well ventilated area with the engine stopped. Never smoke or allow flames or sparks in the area during fuel draining.**

②. Screw off the engine oil dipstick, and screw off the crankcase's drain plug to completely drain off the engine oil of the crankcase. Screw in the drain plug and tighten it, and add new engine oil until oil level reaches the upper limit, then reinstall the engine oil dipstick.

③. Remove the spark plug and add a spoon of clean engine oil into the combustion chamber. Crank the engine several revolutions to distribute the oil, and then reinstall the spark plug.

④. Gently pull the starter grip until resistance is felt, let inlet and exhaust valves in the "closed" state.

⑤. Put the generator in a clean and dry area.

# TROUBLESHOOTING

## 10. TROUBLESHOOTING

Engine unable to start:

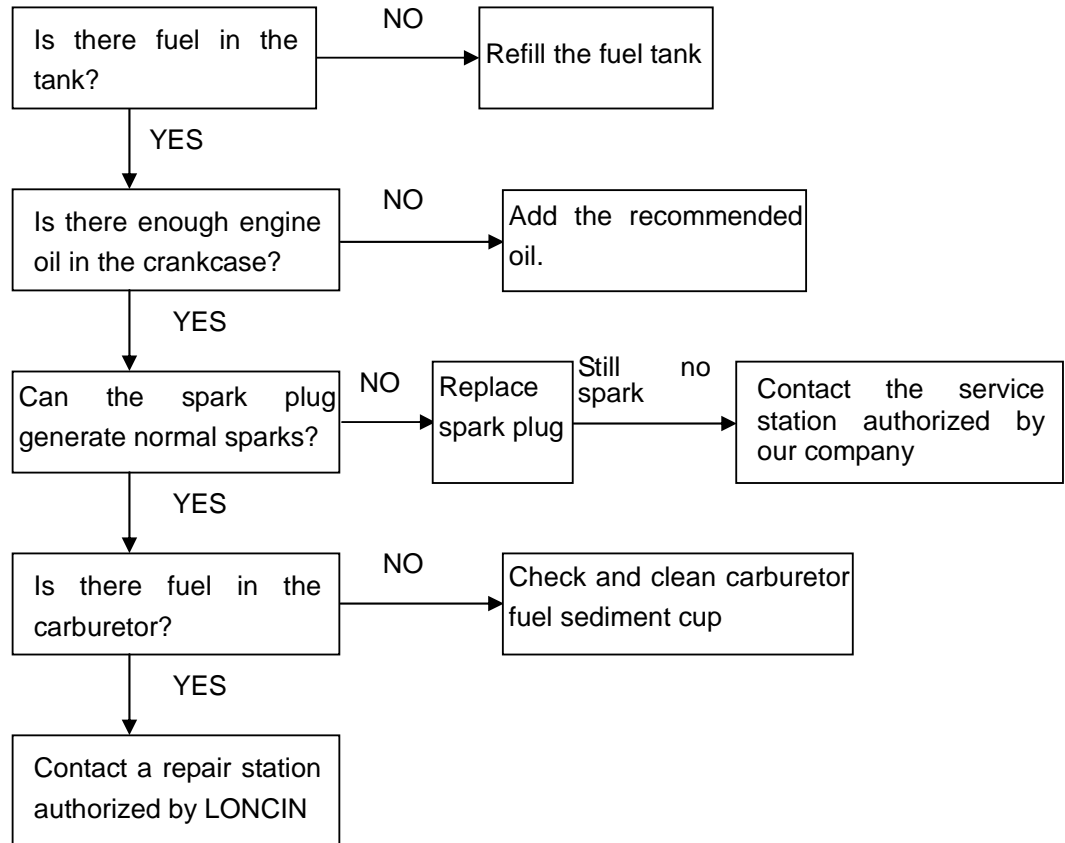

No voltage:

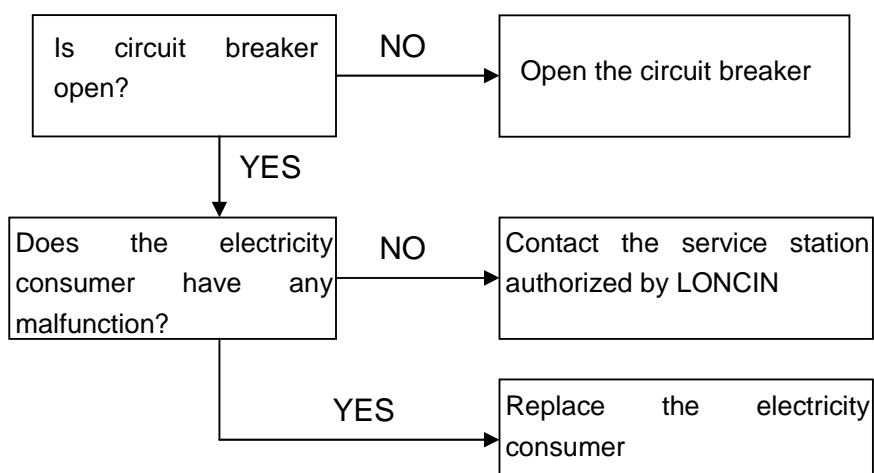

# WIRING DIAGRAM

## 11. WIRING DIAGRAM

### 1) LC2500-J wiring diagram

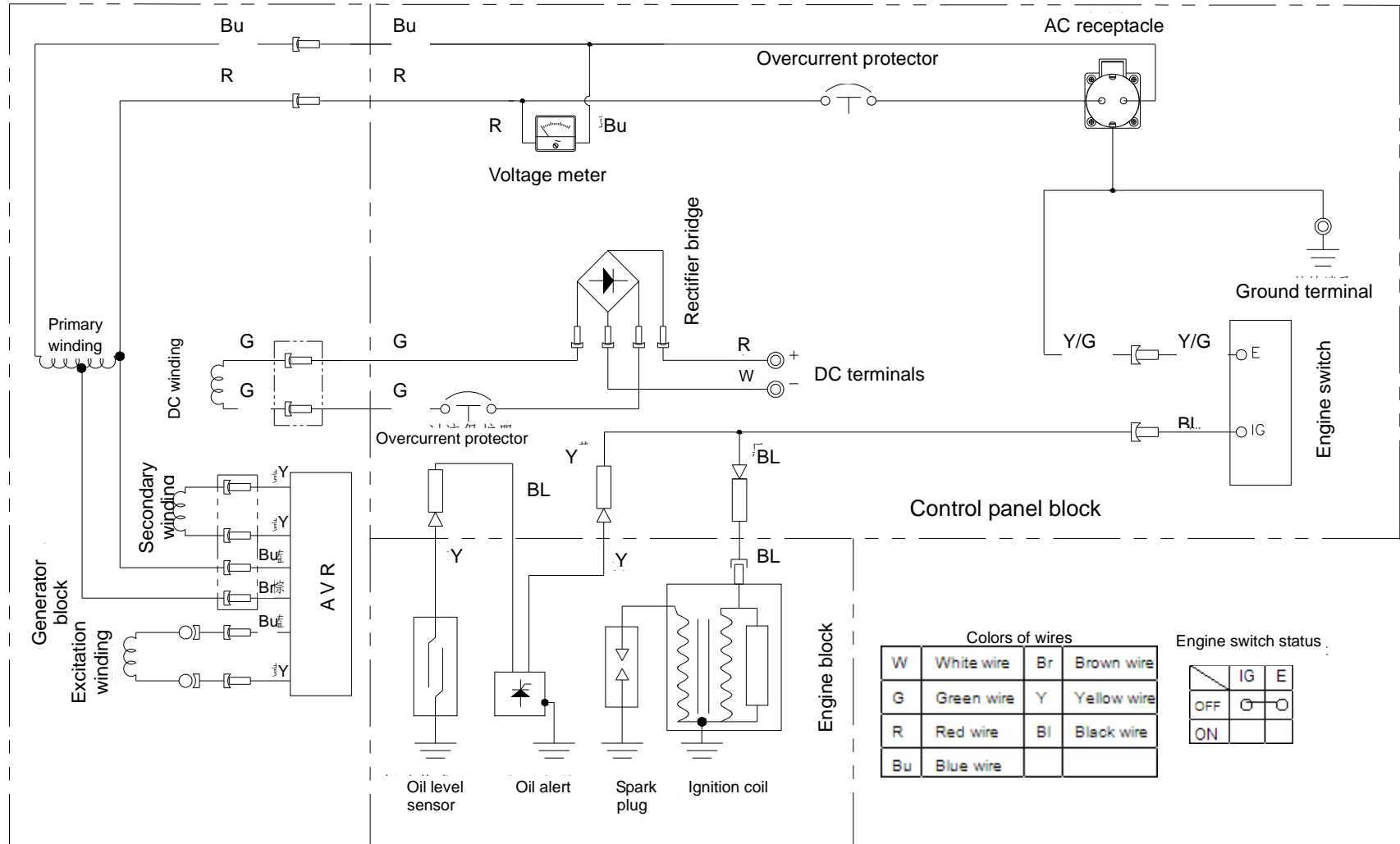

# WIRING DIAGRAM

## 2) LC6500-J wiring diagram

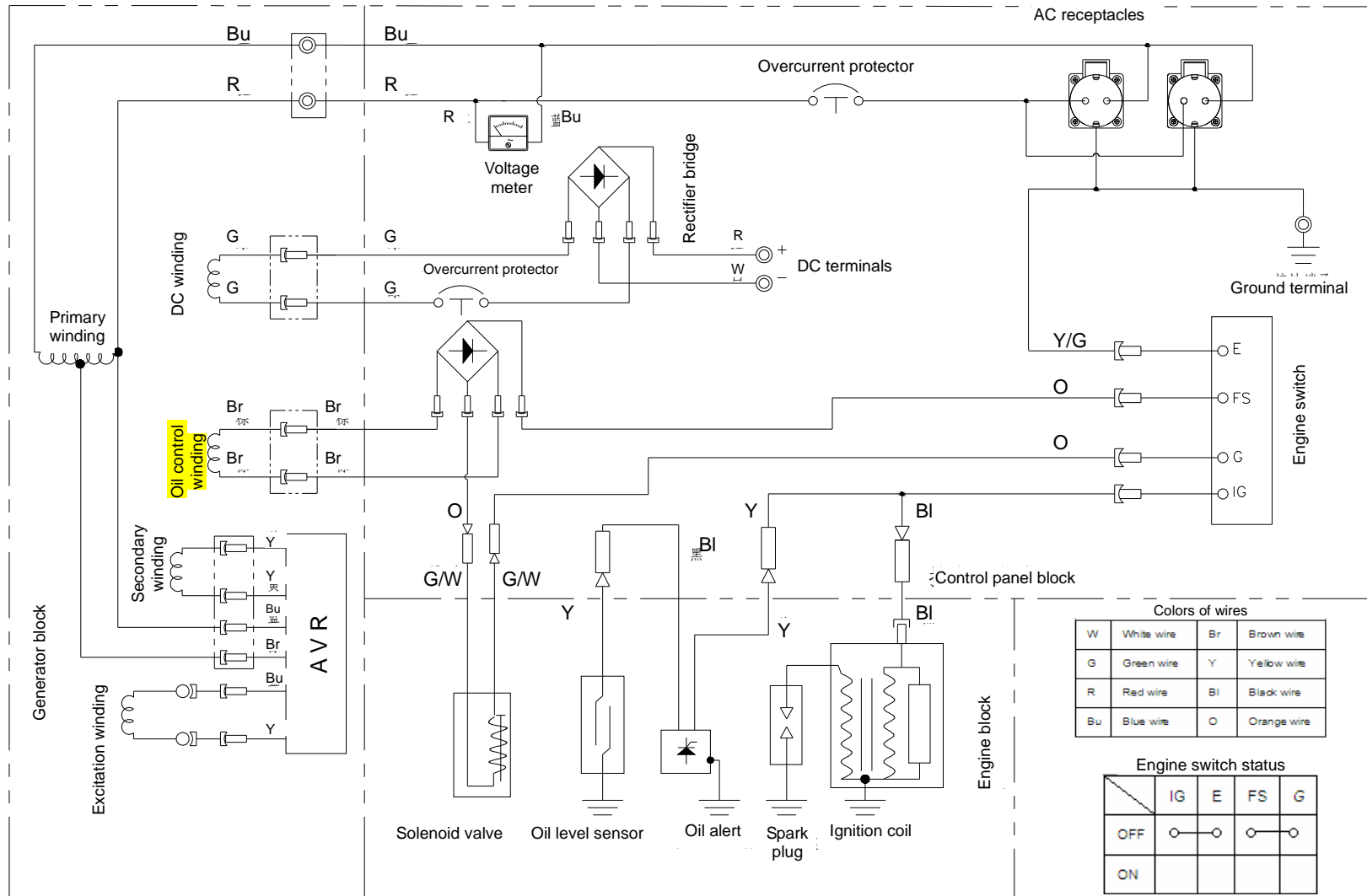

# PARAMETERS

## 12. Parameters

	Item	LC2500-J	LC6500-J
Engine	Engine	LC168F-II	LC188F(D)
	Engine type	Single cylinder, 4-Stroke, forced air cooling, OHV	
	Displacement (cc)	196	389
	Ignition mode	T.C.I.	
	Starting mode	Manual starting	
	Fuel tank capacity (L)	10	18
	Fuel consumption rate (g/ps.h)	395	374
	Engine oil volume (cc)	600	1100
Generator	DC voltage/current (V/A)	12/8.3	12/8.3
	Power factor	1	
	Rated frequency (Hz)	50	
	Rated voltage (V)	230	
	Rated output power(KW)	2	5
	Max. output power (KW)	2.2	5.5
Generator set	Length (mm)	560	675
	Width (mm)	430	485
	Height (mm)	440	500
	Net weight (kg)	37	72
General component	Large-size air filter	•	•
	Large-size muffler	•	•
	Large fuel tank	•	•
	Fuel quantity indicator	-	-
	Voltage meter	•	•
	Voltage regulator	•	•
	Oil alert system	•	•
	Circuit breaker	-	-
Battery bracket	-	-	

Note: • means available; – means unavailable



**Loncin motor co., Ltd.**

Add: No. 99 Hualong Road, Jiulongpo District, Chongqing, China

Tel: 86 23 8980 5678 / 86 23 8980 8505

Fax: 86 23 8906 7566

Email: [marketing@loncinengine.com](mailto:marketing@loncinengine.com)

Website: [www.loncinengine.com](http://www.loncinengine.com)

**PRINTED IN CHINA**