



General Power Products

Gasoline Generator

LC1800(D)-F • LC2500(D)-F • LC3500(D)-F
LC3800(D)-F • LC5000(D)-F • LC6500(D)-F
LC8000(D)-F

Owner's Manual



Thank you for purchasing a generator. We want to help you get the best results from your new generator and to operate it safely.

This manual contains the information on how to do that; please read it carefully.

All information and specifications in this publication is based on the latest product information available at the time of printing. We reserve the right to make changes at any time without notice and without incurring any obligation. No part of this publication may be reproduced without written permission.

This manual should be considered a permanent part of the generator and should remain with it if it is resold.

Safety Messages

Your safety and the safety of others are very important. We have provided important safety messages in this manual and on the generator. Please read these messages carefully.

A safety message alerts you to potential hazards that could hurt you or others. Each safety message is preceded by a safety alert symbol  and one of three words: DANGER, WARNING, or CAUTION. These mean:

 **WARNING** You **WILL** be **KILLED** or **SERIOUSLY HURT** if you don't follow instructions.

 **CAUTION** You **CAN** be **KILLED** or **SERIOUSLY HURT** if you don't follow instructions.

 **DANGER** You **CAN** be **HURT** if you don't follow instructions.

Damage Prevention Messages

Other important messages are preceded by the word NOTICE. This word means:

 **NOTICE** Your generator or other property could be damaged if you don't follow instructions.

The purpose of these messages is to help prevent damage to your generator, other property, or the environment.

CONTENTS

1. SAFETY	3
2. COMPONENT IDENTIFICATION	5
3. CONTROLS.....	7
1) Engine Switch	7
2) Recoil Starter	7
3) Fuel Valve	7
4) Choke.....	8
5) Circuit Breaker.....	8
6) Ground Terminal.....	9
7) Oil Alert System.....	9
4.GENERATOR USE.....	9
1) Connections to a Building's Electrical System.....	9
2) Generator Ground Circuit	10
3) AC Applications.....	10
4) AC Operation.....	11
5) DC Operation.....	11
6) High Altitude Operation.....	13
5. PREOPERATION CHECK	14
1) Engine Oil	14
2) Fuel Recommendation.....	15
6. STARTING/STOPPING THE ENGINE.....	17
7. MAINTENANCE.....	18
1) Maintenance Schedule	18
2) Tool Kit.....	19
3) Engine Oil Change	20
4) Air Cleaner Service	21
5) Fuel Sediment Cup	22
6) Spark Plug	22
8. TRANSPORTING/STORAGE.....	24
9. TROUBLESHOOTING	26
10. WIRING DIAGRAM.....	28
11. SPECIFICATIONS	34
12. OPTIONAL PARTS.....	37

1. SAFETY

The generators are designed to give safe and dependable service if operated according to instructions. Read and understand this owner's manual before operating your generator. You can help prevent accidents by being familiar with your generator's controls, and by observing safe operating procedures.

Operator Responsibility

- Know how to stop the generator quickly in case of emergency.
- Understand the use of all generator controls, output receptacles, and connections.
- Be sure that anyone who operates the generator receives proper instruction. Do not let children operate the generator without parental supervision. Keep children and pets away from the area of operation.
- Place the generator on a firm, level surface and avoid loose sand or snow. If the generator is tilted or overturned, fuel spillage may result. Also, if the generator is overturned or sinks into a soft surface, sand, dirt, or water may enter the generator.

Carbon Monoxide Hazards

- Exhaust contains poisonous carbon monoxide, a colorless and odorless gas. Breathing exhaust can cause loss of consciousness and may lead to death.
- If you run the generator in an area that is confined, or even partially enclosed, the air you breathe could contain a dangerous amount of exhaust gas. To keep exhaust gas from building up, provide adequate ventilation.

Electric Shock Hazards

- The generator produces enough electric power to cause a serious shock or electrocution if misused.
- Using a generator or electrical appliance in wet conditions, such as rain or snow, or near a pool or sprinkler system, or when your hands are wet, could result in electrocution. Keep the generator dry.
- If the generator is stored outdoors, unprotected from the weather, check all electrical components on the control panel, before each use. Moisture or ice can cause a malfunction or short circuit in electrical components which could result in electrocution.
- Do not connect to a building's electrical system unless an isolation switch has been installed by a qualified electrician.

Fire and Burn Hazards

- The exhaust system gets hot enough to ignite some materials.
 - Keep the generator at least 1 meter (3 feet) away from buildings and other equipment during operation.
 - Do not enclose the generator in any structure.
 - Keep flammable materials away from the generator.
- The muffler becomes very hot during operation and remains hot for a while after stopping the engine. Be careful not to touch the muffler while it is hot. Let the engine cool before storing the generator indoors.
- Gasoline is extremely flammable and is explosive under certain conditions. Do not smoke or allow flames or sparks where the generator is refueled or where gasoline is stored. Refuel in a well-ventilated area with the engine stopped.
- Fuel vapors are extremely flammable and may ignite after the engine has started. Make sure that any spilled fuel has been wiped up before starting the generator.

2. COMPONENT IDENTIFICATION

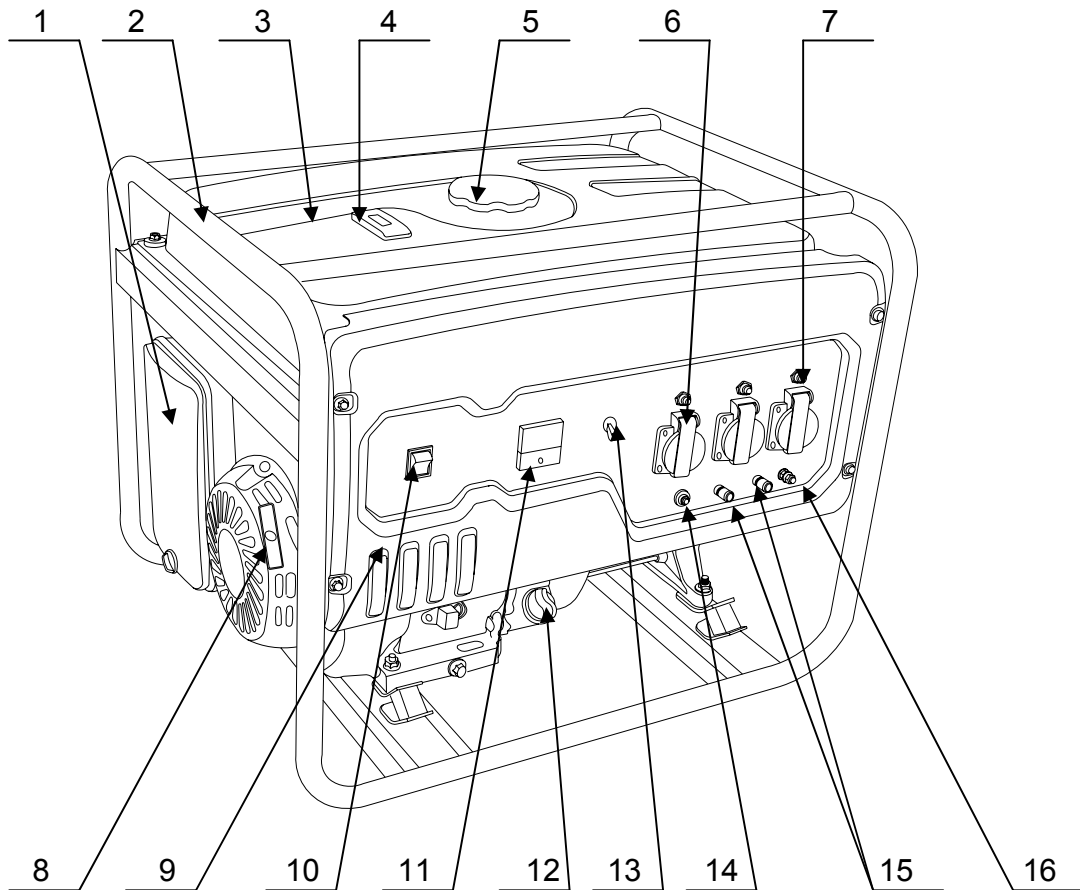

- | | | | |
|-------------------------|------------------------|--------------------------|----------------|
| 1---Air cleaner | 2---Frame | 3---Fuel tank | 4---Fuel meter |
| 5---Fuel tank cap | 6---AC receptacles | 7--- Receptacles breaker | |
| 8---Recoil starter grip | 9---Control panel case | 10---Engine switch | |
| 11---Voltmeter | 12---Oil filler cap | 13---AC breaker | |
| 14---DC breaker | 15---DC receptacles | 16---Ground terminal | |

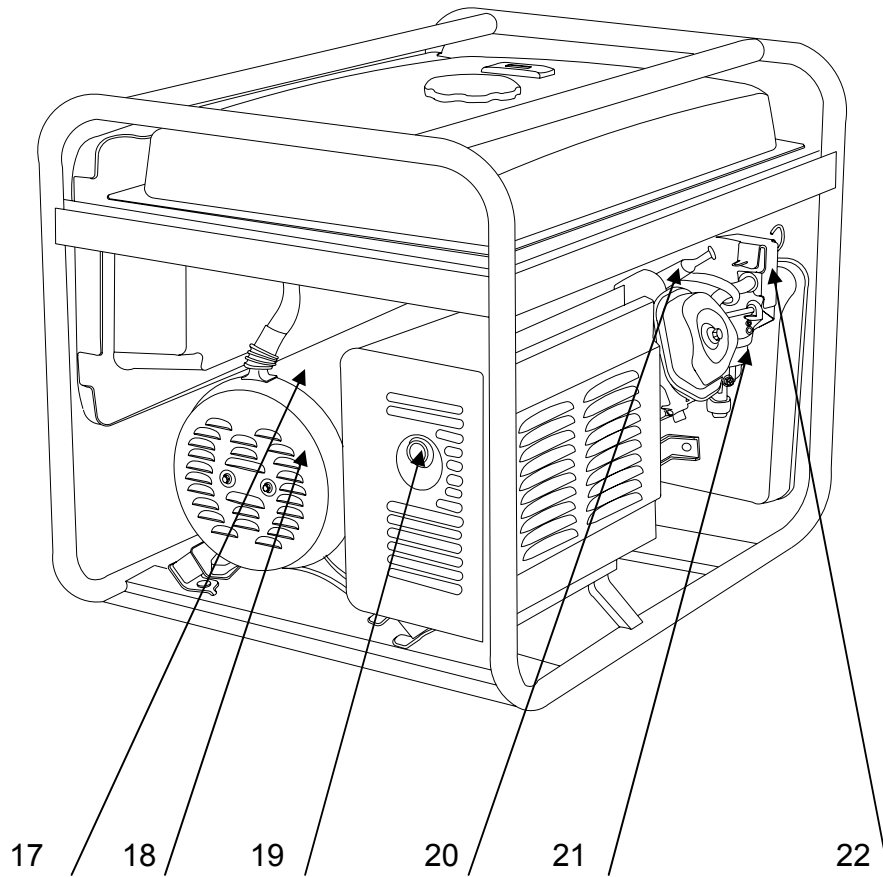

17---Alternator

18---Alternator cover

19---Muffler

20---Spark plug cap

21---Carburetion

22---Choke assy.

3.CONTROLS

1) Engine Switch

To start and stop the engine.

Switch position:

- ① To stop the engine.(OFF)
- ② To run the engine.(ON)
- ③ Starting circuit is switched on, The starter motor starts.

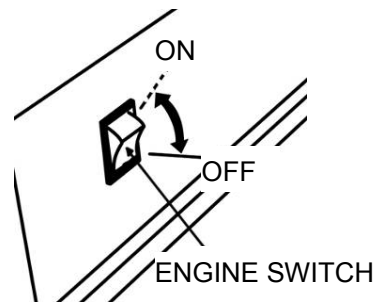
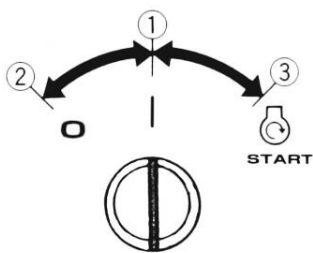

To electric starter (option kit), include the START position.

2) Recoil Starter

To start the engine, pull the starter grip lightly until resistance is felt, then pull briskly.

NOTICE

**Do not allow the starter to snap back against the engine.
Return it gently to prevent damage to the starter.**

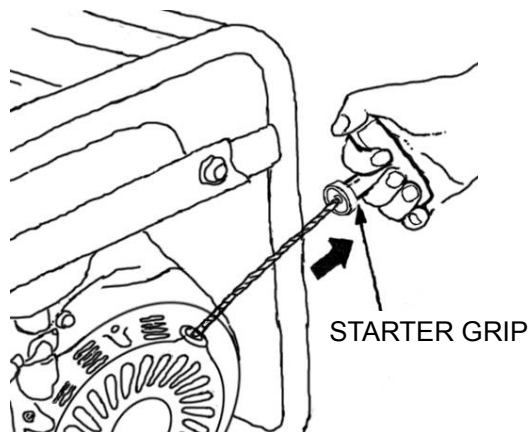

3) Fuel Valve

The fuel valve is located between the fuel tank and carburetor. When the valve lever is in the ON position, fuel is allowed to flow from the fuel tank to the carburetor. Be sure to return the lever to OFF after stopping the engine.

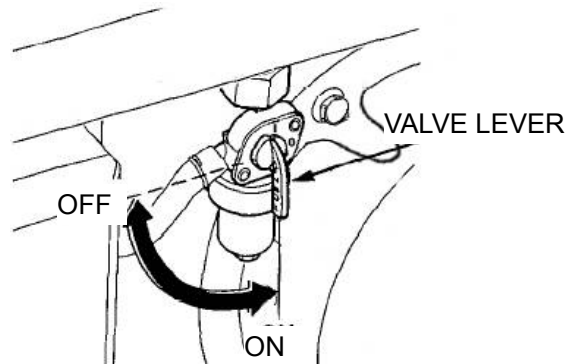

4) Choke

The choke is used to provide an enriched fuel mixture when starting a cold engine. It can be opened and closed by operating the choke lever or choke rod manually. Move the lever or the rod to the CLOSE position to enrich the mixture.

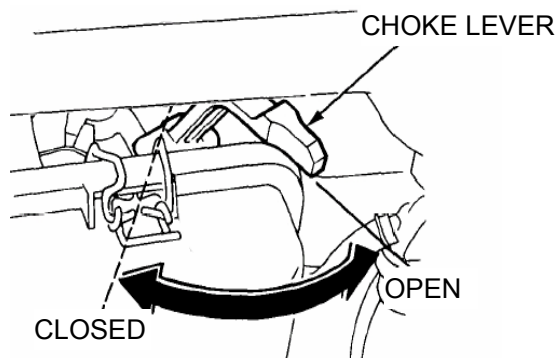
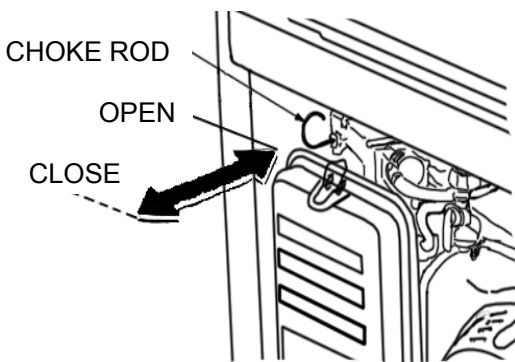

5) Circuit Breaker

The circuit breaker will automatically switch OFF if there is a short circuit or a significant overload of the generator at the receptacle. If the circuit breaker is switched OFF automatically, check that the appliance is working properly and does not exceed the rated load capacity of the circuit before switching the circuit breaker ON again. The circuit breaker may be used to switch the generator power ON or OFF.

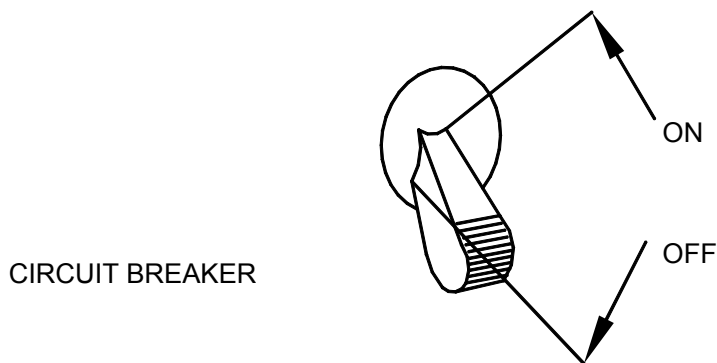

6) Ground Terminal

The generator ground terminal is connected to the panel of the generator, the metal non-current carrying parts of the generator, and the ground terminals of each receptacle. Before using the ground terminal, consult a qualified electrician, electrical inspector or local agency having jurisdiction for local codes or ordinances that apply to the intended use of the generator.

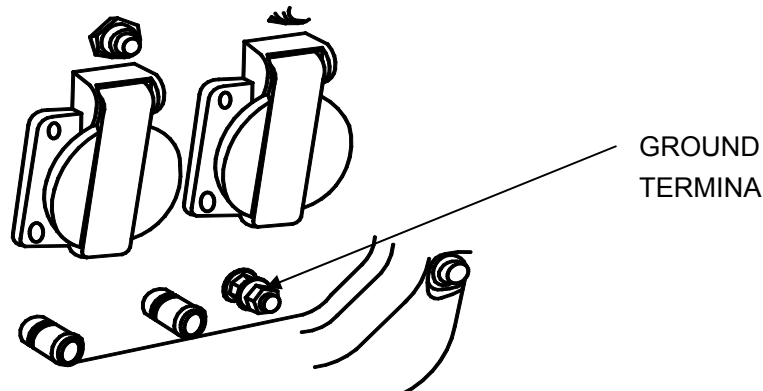

7) Oil Alert System

The oil alert system is designed to prevent engine damage caused by an insufficient amount of oil in the crankcase. Before the oil level in the crankcase can fall below a safe limit, the oil alert system will automatically shut down the engine (the engine switch will remain in the ON position). The oil alert system shuts down the engine and the engine will not start. If this occurs, first check engine oil. (See page 17)

4. GENERATOR USE

1) Connections to a Building's Electrical System

Connections for standby power to a building's electrical system must be made by a qualified electrician. The connection must isolate the generator power from utility power, and must comply with all applicable laws and electrical codes.

⚠ WARNING Improper connections to a building's electrical system, can allow electrical current from the generator to feedback into the utility lines. Such feedback may electrocute utility company workers or others who contact the lines during a power outage. Consult the utility company or a qualified electrician.

⚠ CAUTION Improper connections to a building's electrical system can allow electrical current from the utility company to feedback into the generator. When utility power is restored, the generator may explode, burn, or cause fires in the building's electrical system.

2) Generator Ground System

To prevent electrical shock from faulty appliances, the generator should be grounded. Connect a length of heavy wire between the ground terminal and the ground source. The generators have a system ground that connects generator frame components to the ground terminals in the AC output receptacles. The system ground is not connected to the AC neutral wire. If the generator is tested by a receptacle tester, it will not show the same ground circuit condition as for a home receptacle.

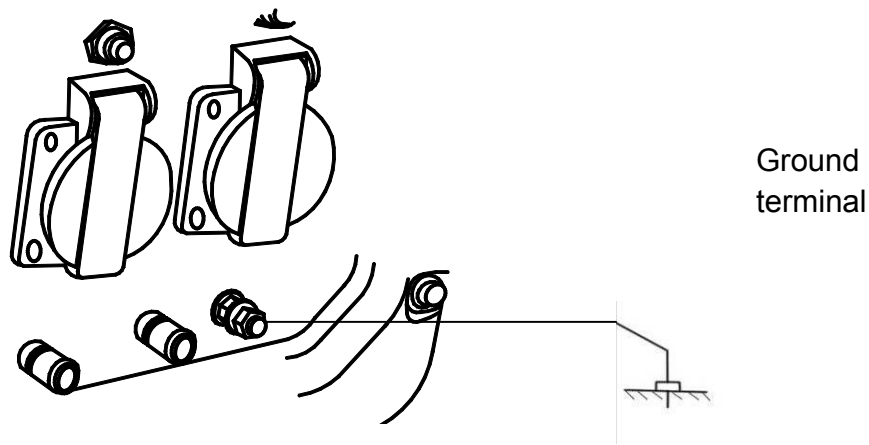

Special Requirements

There may be Federal or State Occupational Safety and Health Administration (OSHA) regulations, local codes, or ordinances that apply to the intended use of the generator. Please consult a qualified electrician, electrical inspector, or the local agency having jurisdiction.

- In some areas, generators are required to be registered with local utility companies.
- If the generator is used at a construction site, there may be additional regulations which must be observed.

3) AC Applications

Before connecting an appliance or power cord to the generator:

- Make sure that it is in good working order. Faulty appliances or power cords can create a potential for electrical shock.
- If an appliance begins to operate abnormally, becomes sluggish or stops suddenly, turn it off immediately. Disconnect the appliance, and determine whether the problem is the appliance, or if the rated load capacity of the generator has been exceeded.
- Make sure that the electrical rating of the tool or appliance does not exceed that of the generator. Never exceed the maximum power rating of the generator. Power levels between rated and maximum may be used for no more than 30 minutes.

NOTICE

Substantial overloading will switch off the circuit breaker. Exceeding the time limit for maximum power operation or slightly overloading the generator may not switch the circuit breaker OFF, but will shorten the service life of the generator.

Limit operation requiring maximum power to 30 minutes.

For continuous operation, do not exceed the rated power.

In either case, the total power requirements (VA) of all appliances connected must be considered. Appliance and power tool manufacturers usually list rating information near the model number or serial number.

4) AC Operation

- ①. Start the engine (refer to page 21).
- ②. Switch the AC circuit breaker ON.
- ③. Plug in the appliance.

Most motorized appliances require more than their rated wattage for startup.

Do not exceed the current limit specified for any one receptacle. If an overloaded circuit causes the AC circuit breaker to switch OFF, reduce the electrical load on the circuit, wait a few minutes and then reset the circuit breaker.

5) DC OPERATION

DC Terminals

The DC terminals may ONLY be used for charging 12 volt automotive type batteries.

The terminals are colored red to identify the positive (+) terminal and black to identify the negative (-) terminal. The battery must be connected to the generator DC terminals with the proper polarity (battery positive to generator red terminal and battery negative to the generator black terminal).

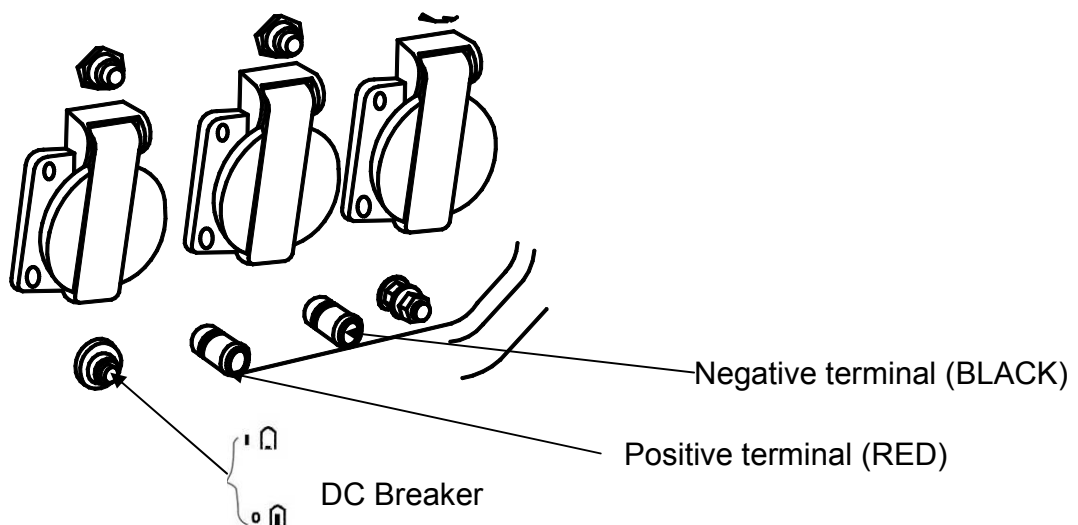

DC Circuit Protector

The DC circuit protector (rated current: 10 A) automatically shuts off the DC battery charging circuit when the DC circuit is overloaded, when there is a problem with the battery, or the connections between the battery and the generator are improper.

The indicator inside the DC circuit protector button will pop out to show that the DC circuit protector has switched off. Wait a few minutes and push the button in to reset the DC circuit protector.

Connecting the battery cables:

- ①. Before connecting charging cables to a battery that is installed in a vehicle, disconnect the vehicle's grounded battery cable.

⚠ WARNING The battery gives off explosive gases; keep spark, flames and cigarettes away. Provide adequate ventilation when charging or using batteries.

- ②. Connect the positive (+) battery cable to the battery positive (+) terminal.
- ③. Connect the other end of the positive (+) battery cable to the generator
- ④. Connect the negative (-) battery cable to the battery negative (-) terminal.
- ⑤. Connect the other end of the negative (-) battery cable to the generator
- ⑥. Start the generator.

NOTICE Do not start the vehicle while the battery charging cables are connected and the generator is running. The vehicle or the generator may be damaged.

An overloaded DC circuit, excessive current draw by the battery, or a wiring problem will trip the DC circuit protector (PUSH button extends out). If this happens, wait a few minutes before pushing in the circuit protector to resume operation. If the circuit protector continues to go OFF, discontinue charging and see your authorized generator dealer.

Disconnecting the battery cables:

- ①. Stop the engine,

-
- ②. Disconnect the negative (-) battery cable from the generator negative (-) terminal.
 - ③. Disconnect the other end of the negative (-) battery cable from the battery negative (-) terminal.
 - ④. Disconnect the positive (+) battery cable from the generator positive (+) terminal.
 - ⑤. Disconnect the other end of the positive (+) battery cable to the battery positive (+) terminal.
 - ⑥. Connect the vehicle ground cable to the battery negative (-) terminal.
 - ⑦. Reconnect the vehicle grounded battery cable.

6) High Altitude Operation

At high altitude, the standard carburetor air-fuel mixture will be excessively rich. Performance will decrease, and fuel consumption will increase.

High altitude performance can be improved by installing a smaller diameter main fuel jet in the carburetor and readjusting the pilot screw. If you always operate the engine at altitudes higher than 5000 feet (1500 meters) above sea level, have an authorized generator dealer perform this carburetor modification.

Even with suitable carburetor jetting, engine horsepower will decrease approximately 3.5% for each 1000 foot (300 meter) increase in altitude. The effect of altitude on horsepower will be greater than this if no carburetor modification is made.

NOTICE If a engine jetted for high altitude is used at a lower altitude, the lean air fuel mixture will reduce performance and may over-heat and seriously damage the engine.

5. PRE-OPERATION CHECK

1) Engine oil

NOTICE Engine oil is a major factor affecting engine performance and service life. Non-detergent and 2-stroke engine oils will damage the engine and are not recommended.

Check the oil level BEFORE EACH USE with the generator on a level surface with the engine stopped.

Use 4-stroke oil, or equivalent high detergent, premium quality motor oil certified to meet or exceed U.S. automobile manufacturer's requirements for Service Classification SG, SF/CC, CD. Motor oils classified SG, SF/CC, CD will show this designation on the container.

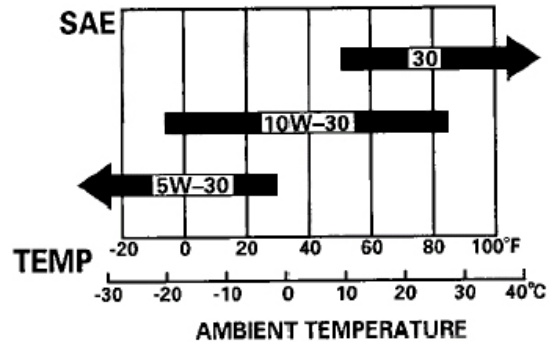

SAE 10W-30 is recommended for general temperature use. Other viscosities shown in the chart may be used when the average temperature in your area is within the indicated range.

1. Remove the oil filler cap and wipe the dipstick clean.
2. Check the oil level by inserting the dipstick into the filler neck without screwing it in.
3. If the level is low, add the recommended oil to the upper mark on the dipstick.

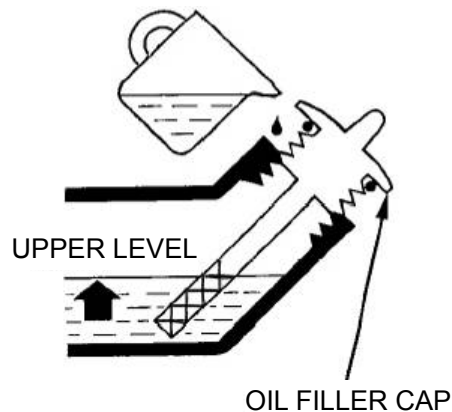
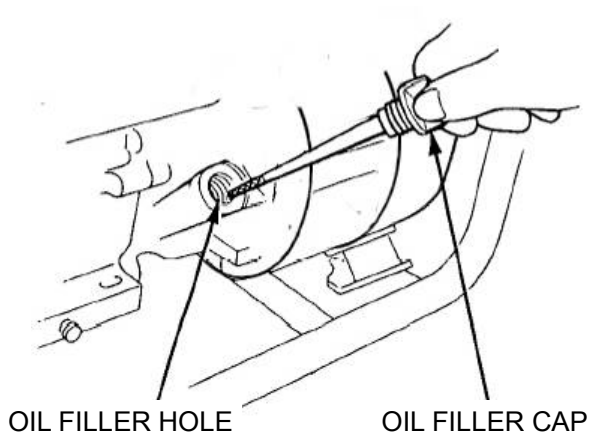

2) Fuel Recommendation

1. Check the fuel level gauge.
2. Refill the tank if the fuel level is low. Do not fill above the shoulder of the fuel strainer.

⚠ WARNING

- Gasoline is extremely flammable and is explosive under certain conditions.
- Refuel in a well-ventilated area with the engine stopped. Do not smoke or allow flames or sparks in the area where the engine is refueled or where gasoline is stored.
- Do not overfill the fuel tank (there should be no fuel in the filler neck). After refueling, make sure the tank cap is closed properly and securely. Be careful not to spill fuel when refueling. Spilled fuel or fuel vapor may ignite. If any fuel is spilled, make sure the area is dry before starting the engine.
- Avoid repeated or prolonged contact with skin or breathing of vapor.
- **KEEP OUT OF REACH OF CHILDREN.**

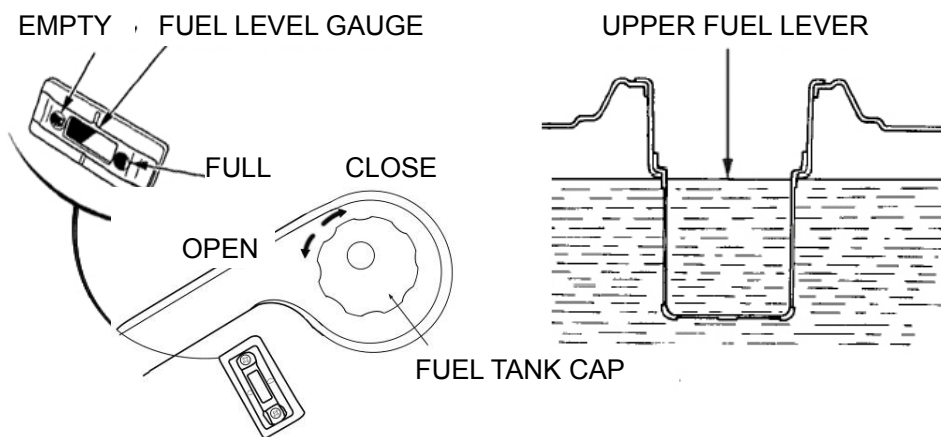

Use gasoline with a pump octane rating of 86 or higher.

We recommend unleaded gasoline because it produces fewer engine and spark plug deposits and extends exhaust system life.

Never use stale or contaminated gasoline or oil/gasoline mixture. Avoid getting dirt or water in the fuel tank.

Occasionally you may hear light “spark knock” or “pinging” (metallic rapping noise) while operating under heavy loads. This is no cause for concern.

If spark knock or pinging occurs at a steady engine speed, under normal load, change brands of gasoline. If spark knock or pinging persists, see an authorized generator dealer.

NOTICE

Running the engine with persistent spark knock or pinging can cause engine damage.

Running the engine with persistent spark knock or pinging is misuse, and the Distributor’s Limited Warranty does not cover parts damaged by misuse.

Oxygenated Fuels

Some gasoline are blended with alcohol or an ether compound to increase the octane. These gasoline are collectively referred to as oxygenated fuels. Some areas of the United States use oxygenated fuels to help meet clean air standards.

If you use an oxygenated fuel, be sure its pump octane rating is 86 or higher.

Ethanol (ethyl or grain alcohol)

Gasoline containing more than 10% ethanol by volume may cause starting or performance problems. Gasoline containing ethanol may be marketed under the name "Gasohol".

Methanol (methyl or wood alcohol)

Gasoline containing methanol must contain cosolvents and corrosion inhibitors to protect the fuel system. Gasoline containing more than 5% methanol by volume may cause starting and/or performance problems and may damage metal, rubber and plastic parts of your fuel system.

MTBE (methyl tertiary butyl ether)

You may use gasoline containing up to 15% MTBE by volume.

Before using an oxygenated fuel, try to confirm the fuel's contents. Some states (provinces in Canada) require this information to be posted on the pump. If you notice any undesirable operating symptoms, switch to a conventional unleaded gasoline. Fuel system damage or performance problems resulting from the use of an oxygenated fuel are not ours responsibility and are not covered under warranty.

NOTICE

Oxygenated fuels can damage paint and plastic. Be careful not to spill fuel when filling your fuel tank. Damage caused by spilled fuel is not covered under warranty.

6. STARTING/STOPPING THE ENGINE

Starting the engine

- ①. Make sure that the AC circuit breaker is in the OFF position.
The generator may be hard to start if a load is connected.
- ②. Turn the fuel valve to the ON position.
- ③. Turn the choke lever or to the CLOSE position, or pull the choke rod out to the CLOSE position.
- ④. Start the engine

• With recoil starter:

Turn the engine switch to the ON position.

Pull the starter grip until compression is felt, then pull briskly.

NOTICE

Do not allow the starter grip to snap back against the engine. Return it gently to prevent damage to the starter or housing.

- **With electric starter: (Optional kit)**

Turn the engine switch to the START position and hold it there for 5 seconds or until the engine starts.

NOTICE

Operating the starter motor for more than 5 seconds can damage the motor. If the engine fails to start, release the switch and wait 10 seconds before operating the starter again.

If the speed of the starter motor drops after a period of time, it is an indication that the battery should be recharged.

When the engine starts, allow the engine switch to return to the ON position.

- ⑤. Turn the choke lever or push the choke rod to the OPEN position as the engine warms up.

Stopping the engine

In an emergency:

To stop the engine in an emergency, move the engine switch to the OFF position.

In normal use:

- ①. Turn the AC circuit breaker to the OFF position.
Disconnect the DC battery charging cables.
- ②. Turn the engine switch to the OFF position.
- ③. Turn the fuel valve to the OFF position.

7. MAINTENANCE

Good maintenance is essential for safe, economical, and trouble-free operation. It will also help reduce air pollution.

⚠ WARNING

Exhaust gas contains poisonous carbon monoxide. Shut off the engine before performing any maintenance. If the engine must be run, make sure the area is well ventilated.

Periodic maintenance and adjustment is necessary to keep the generator in good operating condition. Perform the service and inspection at the intervals shown in the Maintenance schedule below.

1) MAINTENANCE SCHEDULE

REGULAR SERVICE PERIOD Performed at every indicated month or operating hour interval, whichever comes first.		Each use	First month or 20 Hrs. (3)	Every 3 months or 50 Hrs. (3)	Every 6 months or 100 Hrs. (3)	Every year or 300 Hrs. (3)
ITEM						
Engine oil	Check level	○				
	Change		○		○	
Air cleaner	Check	○				
	Clean			○(1)		
Sediment Cup	Clean				○	
Spark plug	Check-Clean				○	
Spark arrester	Clean				○	
Valve clearance	Check-Adjust					○(2)
Fuel tank and strainer	Clean					○(2)
Fuel line	Check	Every 2 years (Replace if necessary) (2)				

(1) Service more frequently when used in dusty areas.

(2) These items should be serviced by an authorized generator dealer, unless the owner has the proper tools and is mechanically proficient.

(3) For professional commercial use, long hours of operation to determine proper maintenance intervals.

⚠ WARNING

Improper maintenance, or failure to correct a problem before operation, can cause a malfunction in which you can be seriously hurt or killed.

Always follow the inspection and maintenance recommendations and schedules in this owner's manual.

The maintenance schedule applies to normal operating conditions. If you operate your generator under severe conditions, such as sustained high-load or high-temperature operation, or use it in unusually wet or dusty conditions, consult your servicing dealer for recommendations applicable to your individual needs and use.

2) Tool kit

The tools supplied with the generator will help you to perform the owner maintenance procedures listed on the following page. Always keep this tool kit with the generator.

AC Plug



PLUG WRENCH

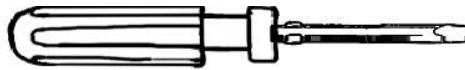

SCREW DRIVER



HANDLE

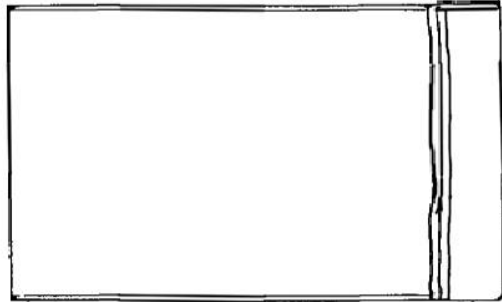

TOOL BAG

AC PLUS
OPTIONAL ACCESSORIES

3) Engine oil change

Drain the oil while the engine is warm to assure complete and rapid draining.

1. Remove the drain plug and sealing washer, oil filler cap, and drain the oil.
2. Reinstall the drain plug and sealing washer. Tighten the plug securely.
3. Refill with the recommended oil (see page 21) and check the oil level.

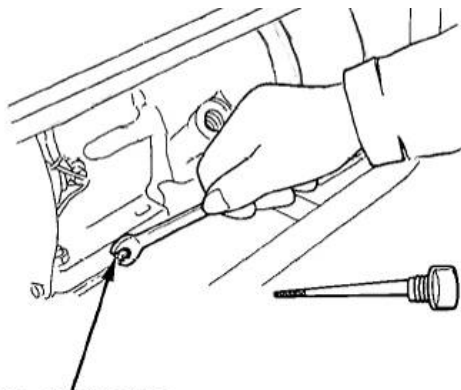

OIL DRAIN PLUG

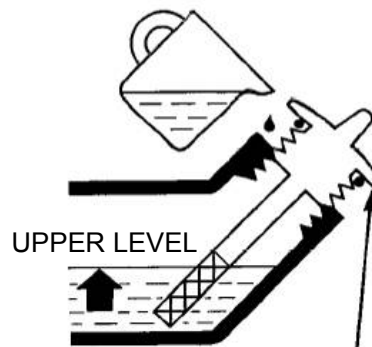

OIL FILLER CAP

⚠ CAUTION

Used motor oil may cause skin cancer if repeatedly left in contact with the skin for prolonged periods. Although this is unlikely unless you handle used oil on a daily basis, it is still advisable to thoroughly wash your hands with soap and water as soon as possible after handling used oil.

Please dispose of used motor oil in a manner that is compatible with the environment. We suggest you take it in a sealed container to your local service station or recycling center for reclamation. Do not throw it in the trash or pour it on the ground.

4) Air cleaner service

A dirty air cleaner will restrict air flow to the carburetor. To prevent carburetor malfunction, service the air cleaner regularly. Service more frequently when operating the generator in extremely dusty areas.

⚠ WARNING

Using gasoline or flammable solvent to clean the filter element can cause a fire or explosion. Use only soapy water or nonflammable solvent.

NOTICE

Never run the generator without the air cleaner. Rapid engine wear will result.

- ①. Unsnap the air cleaner cover clips, remove the air cleaner cover, and remove the element.
- ②. Wash the element in a solution of household detergent and warm water, then rinse thoroughly; or wash in nonflammable or high flash point solvent. Allow the element to dry thoroughly.
- ③. Soak the element in clean engine oil and squeeze out the excess oil. The engine will smoke during initial start-up if too much oil is left in the element.
- ④. Reinstall the air cleaner element and the cover.

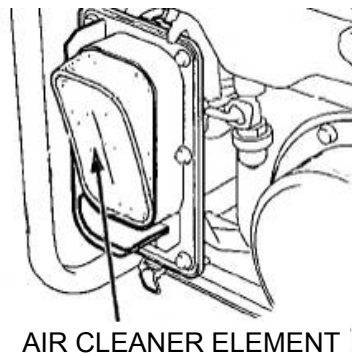
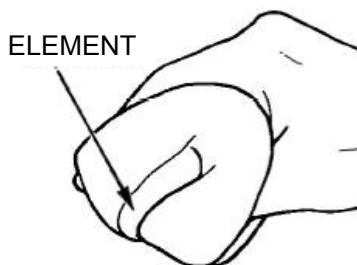
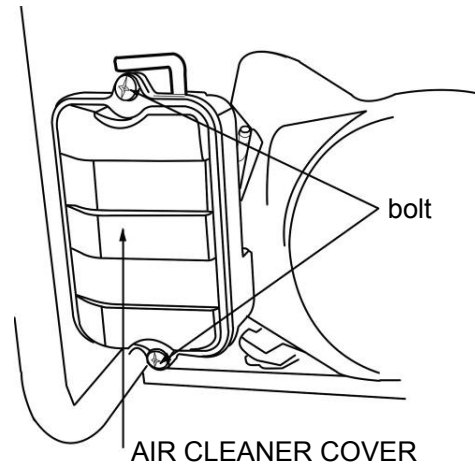

5) Fuel Sediment Cup Cleaning

The sediment cup prevents dirt or water which may be in the fuel tank from entering the carburetor. If the engine has not been run for a long time, the sediment cup should be cleaned.

- ①. Turn the fuel valve to the OFF position. Remove the sediment cup, and o-ring.
- ②. Clean the sediment cup, and o-ring, in nonflammable or high flash point solvent.
- ③. Reinstall o-ring, and sediment cup.
- ④. Turn the fuel valve ON and check for leaks.

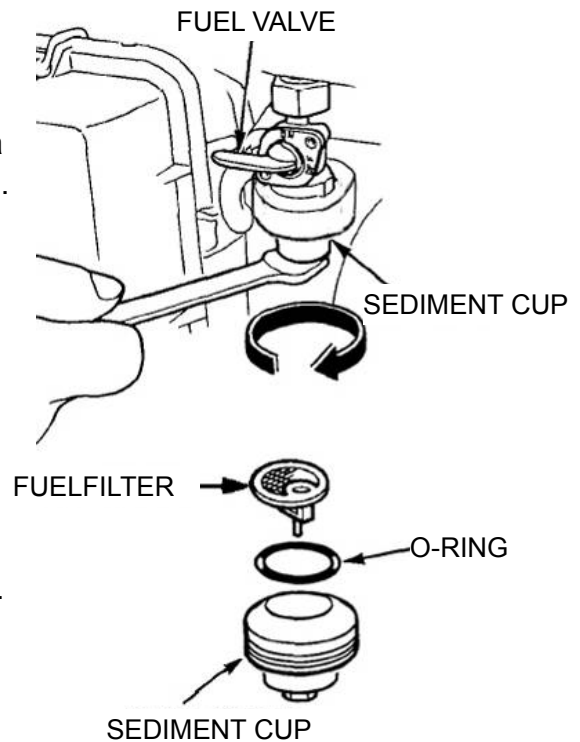

6) Spark Plug Service

Recommended spark plugs: F7RTC or other equivalents.

To ensure proper engine operation, the spark plug must be properly gapped and free of deposits.

If the engine has been running, the muffler will be very hot. Be careful not to touch the muffler.

- ①. Remove the spark plug cap.
- ②. Clean any dirt from around the spark plug base.
- ③. Use the wrench supplied in the tool kit to remove the spark plug.

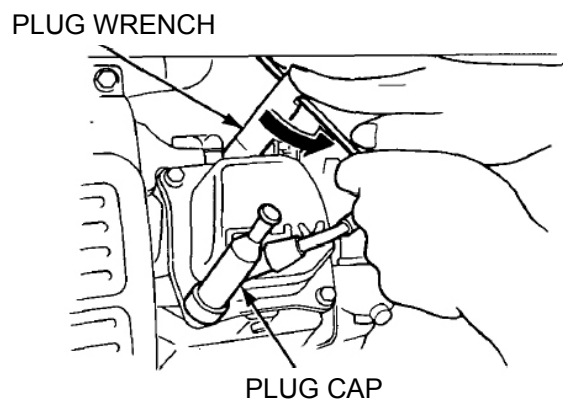

④. Visually inspect the spark plug. Discard it if the insulator is cracked or chipped.
Clean the spark plug with a wire brush if it is to be reused.

⑤. Measure the plug gap with a feeler gauge.
Correct as necessary by carefully bending the side electrode.

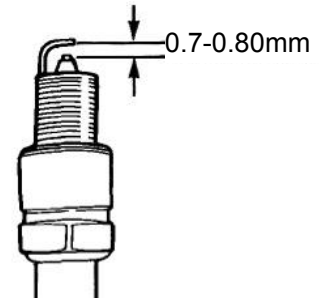

The gap should be: 0.70 mm -0.80 mm (0.028 in -0.031 in).

⑥. Check that the spark plug washer is in good condition, and thread the spark plug in by hand to prevent cross-threading.

⑦. After the spark plug is seated, tighten with a spark plug wrench to compress the washer.

If installing a new spark plug, tighten 1/2 turn after the spark plug seats to compress the washer. If reinstalling a used spark plug, tighten 1/8 - 1/4 turn after the spark plug seats to compress the washer.

NOTICE

The spark plug must be securely tightened. An improperly tightened spark plug can become very hot and could damage the engine. Never use spark plugs which have an improper heat range. Use only the recommended spark plugs or equivalent.

8. TRANSPORTING/STORAGE

When transporting the generator, turn the engine switch and the fuel valve OFF. Keep the generator level to prevent fuel spillage. Fuel vapor or spilled fuel may ignite.

⚠ WARNING

Contact with a hot engine or exhaust system can cause serious burns or fires. Let the engine cool before transporting or storing the generator.

Take care not to drop or strike the generator when transporting. Do not place heavy objects on the generator.

Before storing the unit for an extended period:

- Be sure the storage area is free of excessive humidity and dust.
- Service according to the table below:

STORAGE TIME	RECOMMENDED SERVICE PROCEDURE TO PREVENT HARD STARTING
Less than 1 month	No preparation required
1 to 2 months	Fill with fresh gasoline and add gasoline conditioner*
2 months to 1 year	Fill with fresh gasoline and add gasoline conditioner* Drain the carburetor float bowl (page 32). Drain the fuel sediment cup (page 26)
1 year or more	Fill with fresh gasoline and add gasoline conditioner* Drain the carburetor float bowl (page 32). Drain the fuel sediment cup (page 26). Remove the spark plug. Put a tablespoon of engine oil into the cylinder. Turn the engine slowly with the pull rope to distribute the oil. Reinstall the spark plug. Change the engine oil (page 24) After removal from storage, drain the stored gasoline into a suitable container, and fill with fresh gasoline before starting.
*Use gasoline conditioners that are formulated to extend storage life. Contact your authorized generator dealer for conditioner recommendations.	

- ①. Drain the carburetor by loosening the drain screw. Drain the gasoline into a suitable container.

⚠ WARNING Gasoline is extremely flammable and is explosive under certain conditions. Perform this task in a well ventilated area with the engine stopped. Do not smoke or allow flames or sparks in the area during this procedure.

- ②. Change the engine oil.
- ③. Remove the spark plug, and pour about a tablespoon of clean engine oil into the cylinder. Crank the engine several revolutions to distribute the oil, then reinstall the spark plug.

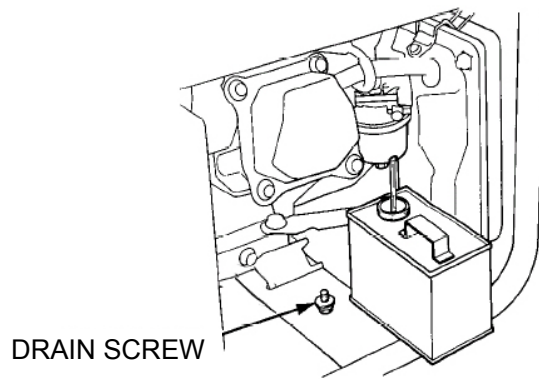

- ④. Slowly pull the starter grip until resistance is felt. At this point, the piston is coming up on its compression stroke and both the intake and exhaust valves are closed. Storing the engine in this position will help to protect it from internal corrosion.

9. TROUBLESHOOTING

When the engine will not start:

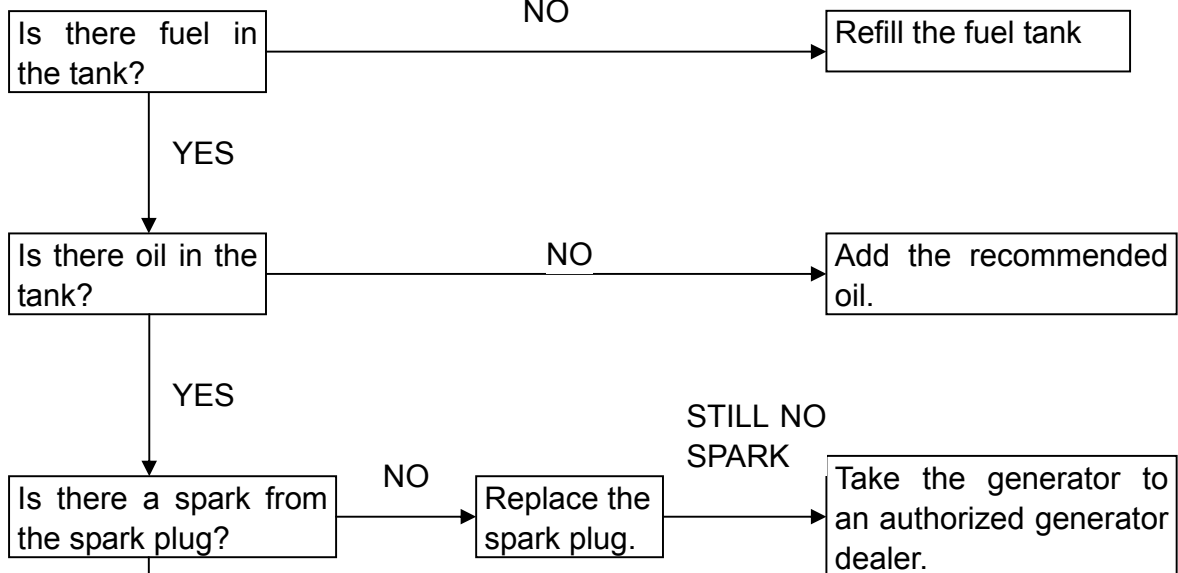

⚠ WARNING Be sure there is no spilled fuel around the spark plug. spilled fuel may ignite.

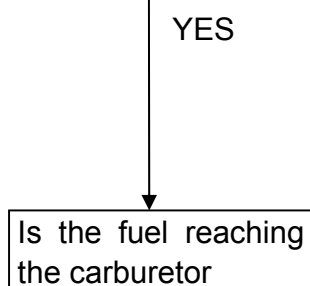

If the engine still dose not start, take the generator to an authorized generator

To check:

- 1) Remove the spark plug cap and clean any dirt from around the spark plug.
- 2) Remove the spark plug and install the spark plug in the plug cap.
- 3) set the plug side electrode on the cylinder head.
- 4) Crank the engine, sparks should jump across the gap.

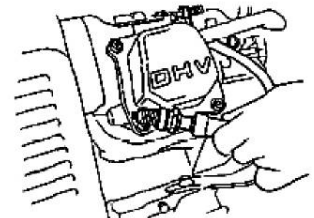

NO

To check:

- 1) Turn off the engine switch and loosen the drain screw.
- 2) Fuel should flow from the drain when the engine switch is turned on.

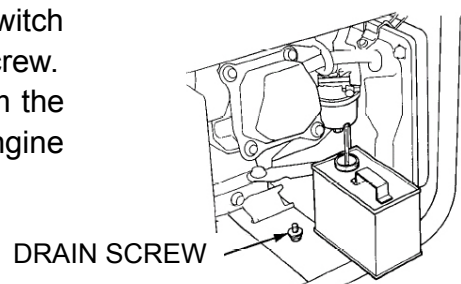

No electricity at the AC receptacles:

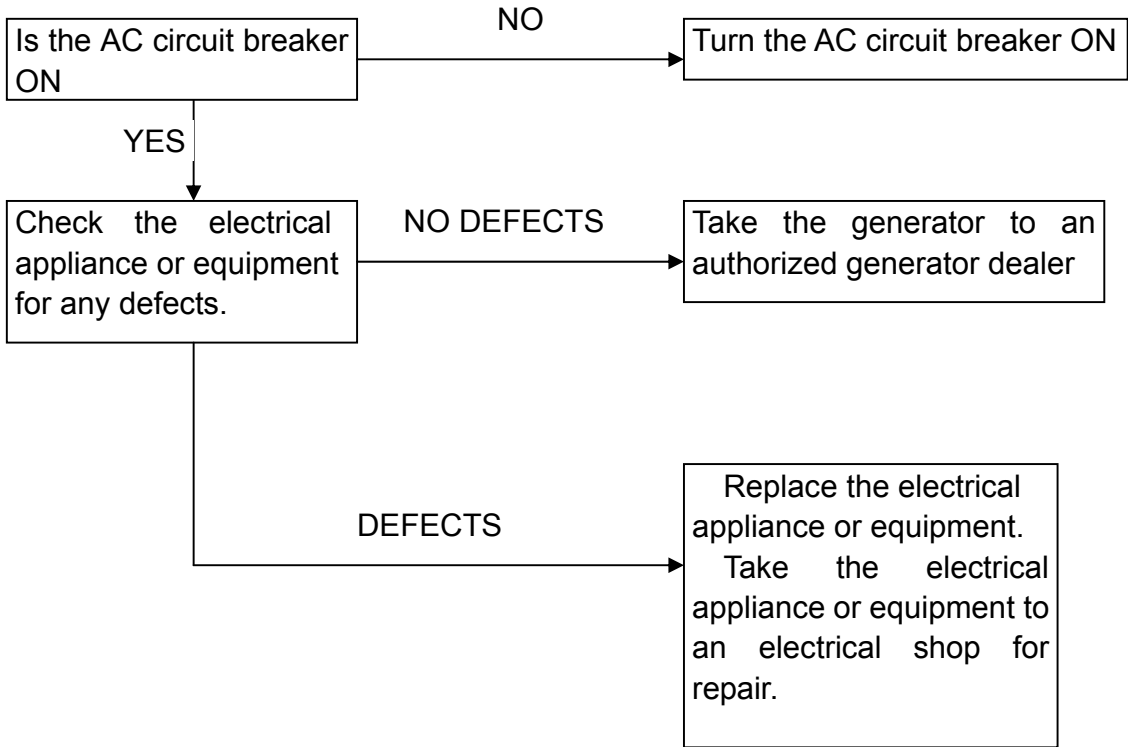

10. WIRING DIAGRAM

WIRING DIAGRAM OF 3800-F, 5000-F, 6500-F, 8000-F

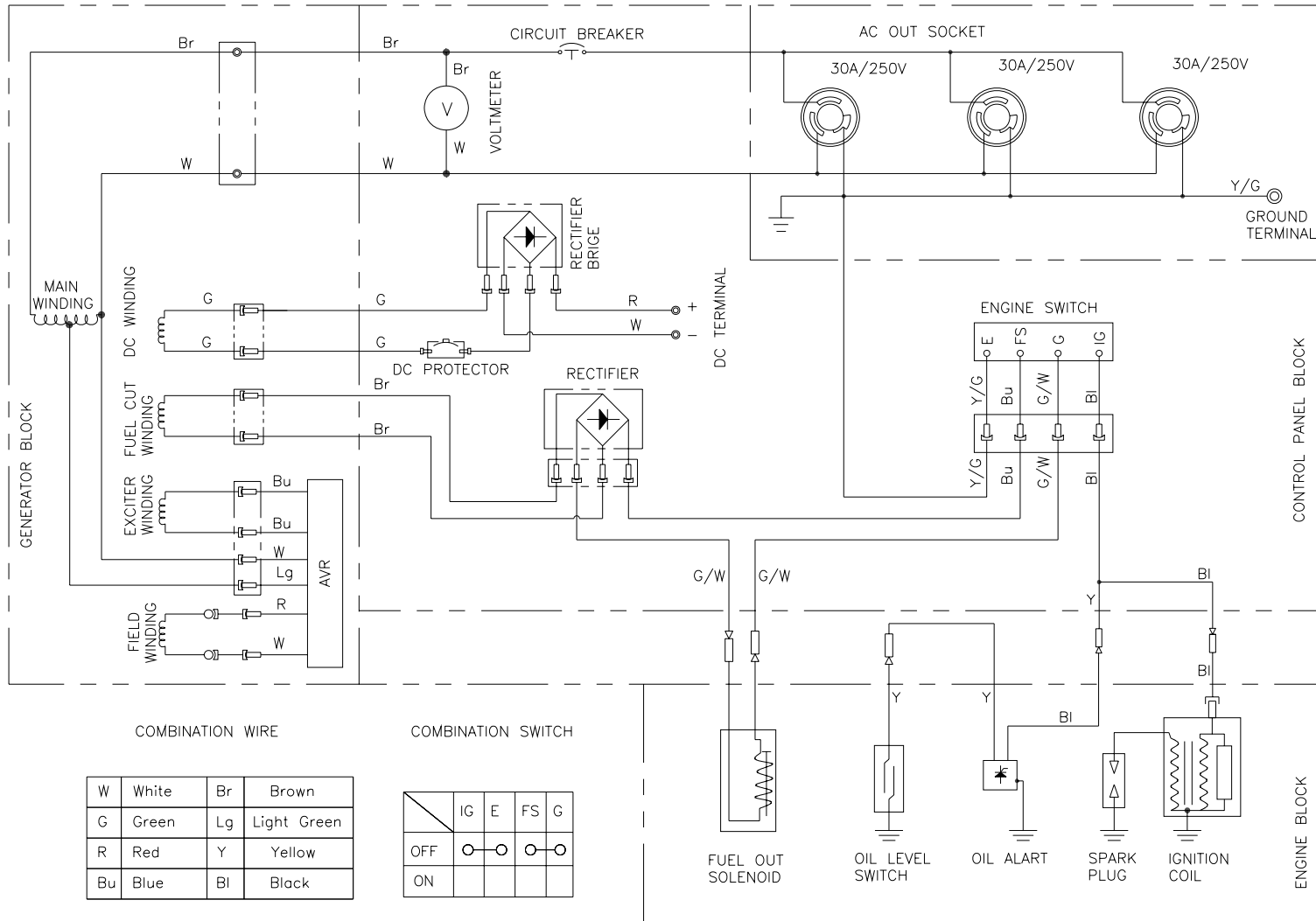

WIRING DIAGRAM OF 3800D-F, 5000D-F, 6500D-F, 8000D-F

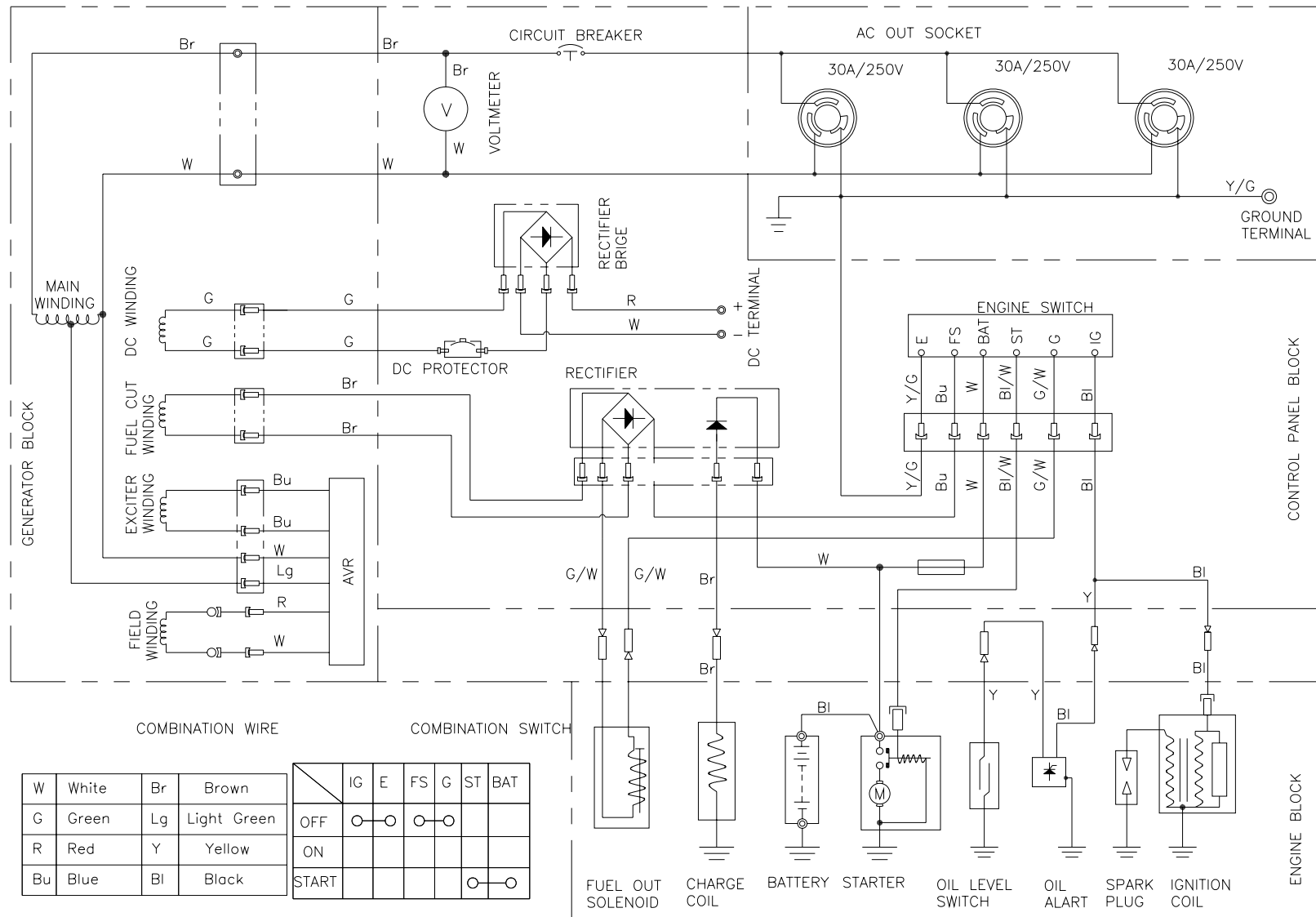

WIRING DIAGRAM OF 8000D-F, 6500D-F THREE PHASE

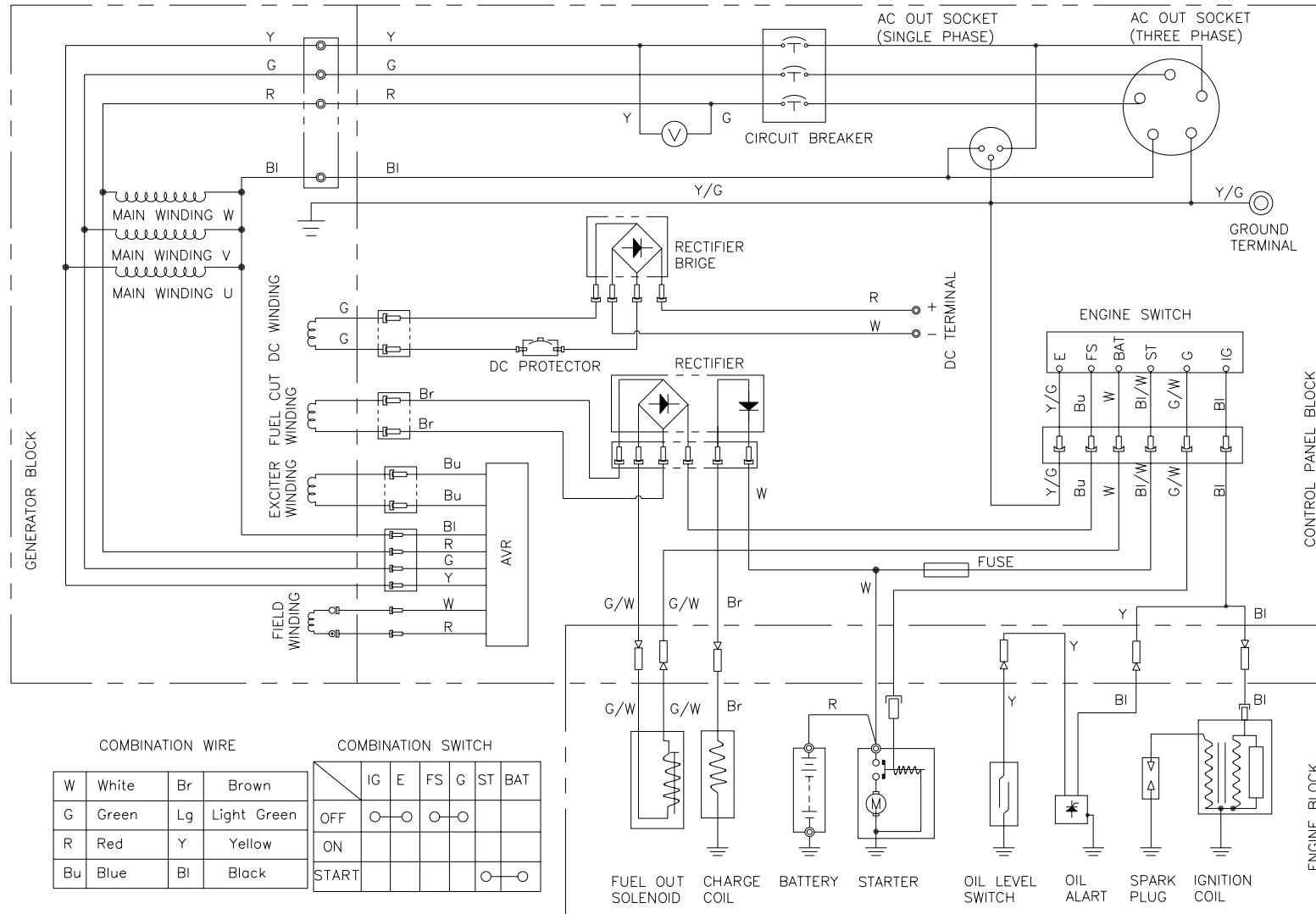

COMBINATION WIRE				COMBINATION SWITCH						
W	White	Br	Brown	IG	E	FS	G	ST	BAT	
G	Green	Lg	Light Green	OFF	○	○	○			
R	Red	Y	Yellow	ON						
Bu	Blue	Bl	Black	START				○	○	

WIRING DIAGRAM OF 8000-F, 6500-F THREE PHASE

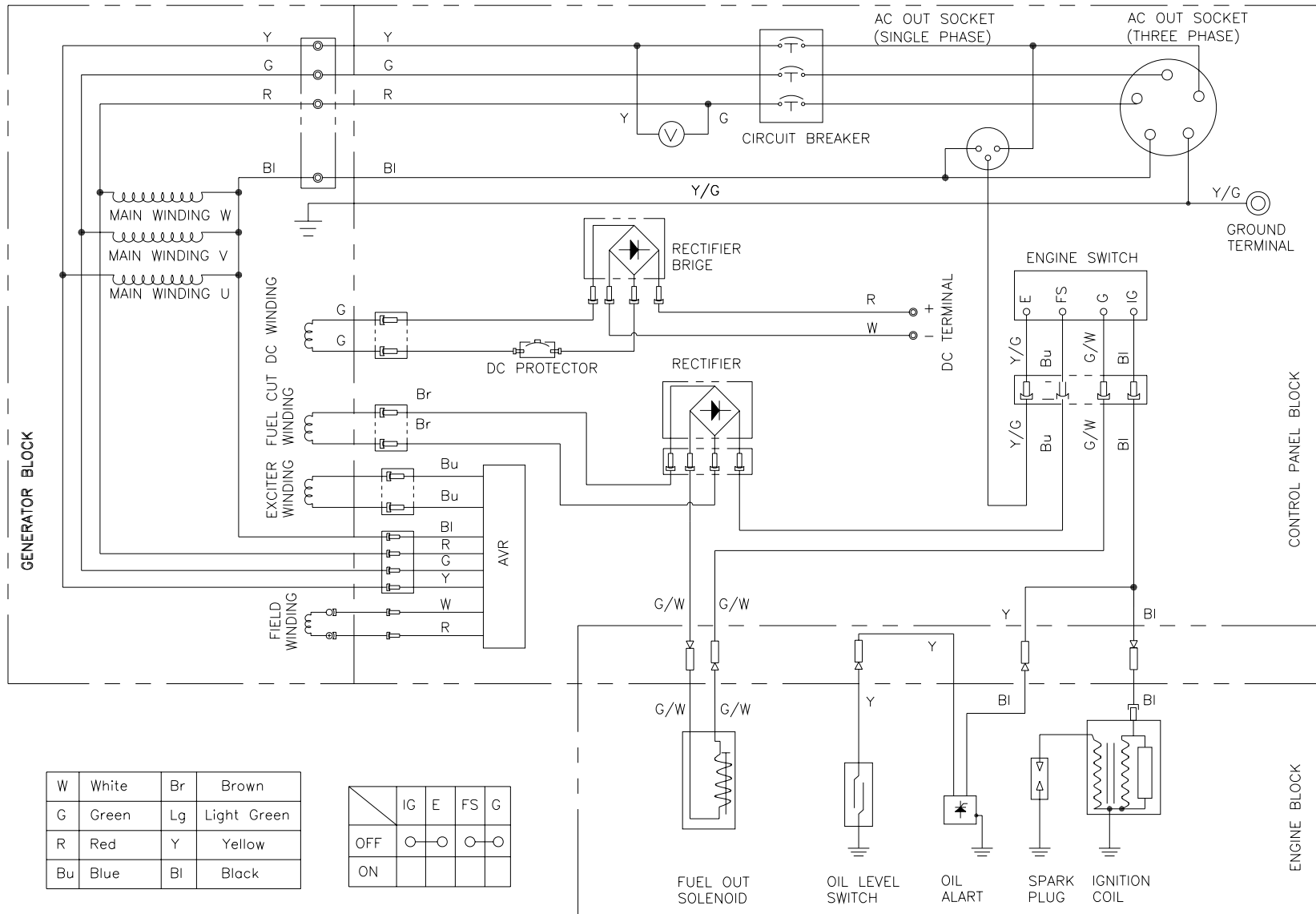

WIRING DIAGRAM OF 1800D-F、2500D-F、3000D-F

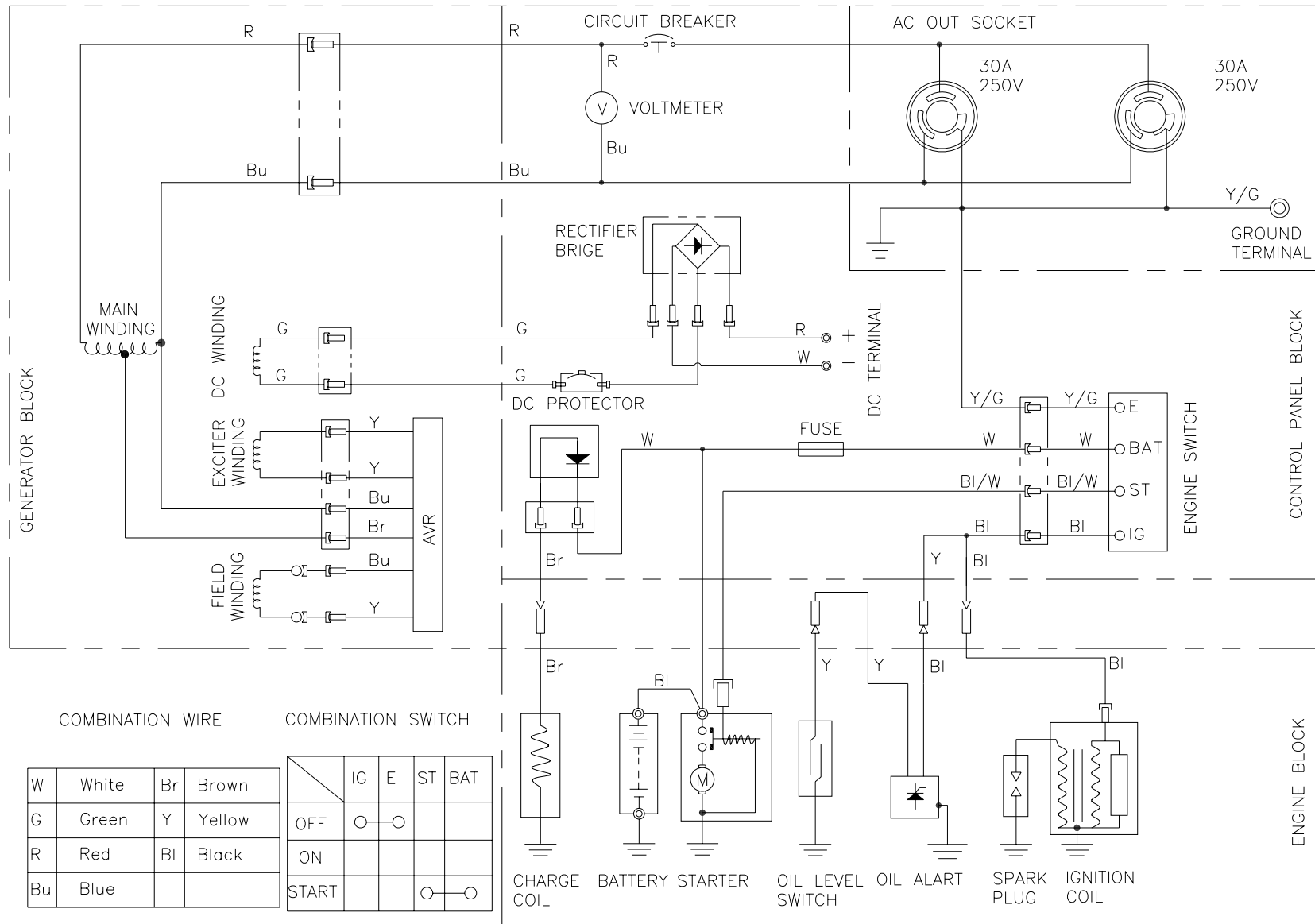

WIRING DIAGRAM OF 1800-F、2500-F、3000-F

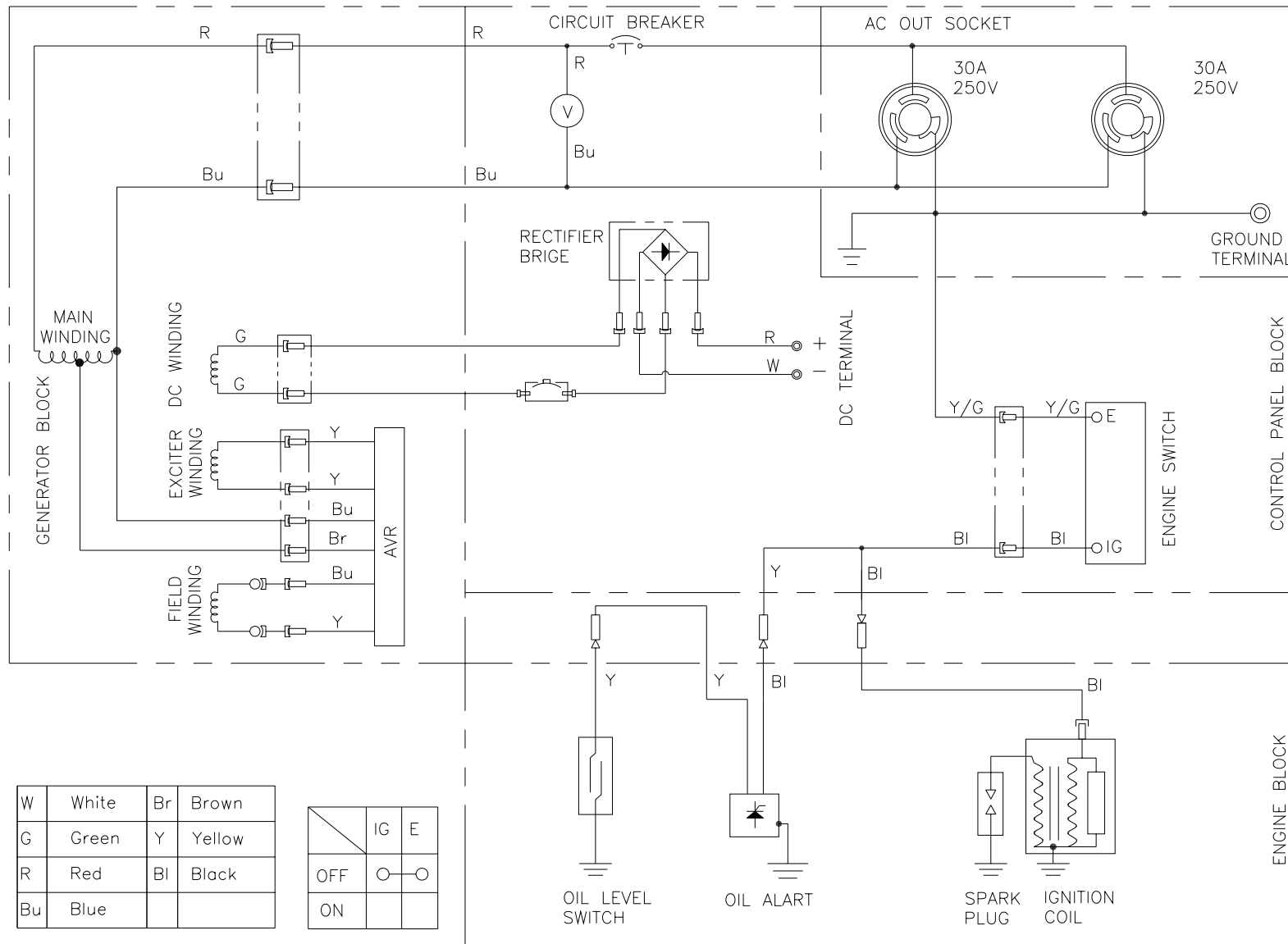

11. SPECIFICATIONS

	Item	1800(D)-F	2500(D)-F	3000(D)-F
Engine	Engine Type	168F(D)-1	168F(D)-2	168F(D)-2
	Engine Mode	Single cylinder, Forced Air Cooling,4-Stroke,OHV25° inclined		
	Displacement(cc)	163	196	
	Rated power(kW/3600rpm)	3.6	4.1	
	Igniting Mode	T.C.I.		
	Fuel Volume(L)	18		
	Fuel consumption(g/ps.h)	≤395	≤374	
	Continuing Time(hr)	19	15	
	Oil Volume(cc)	600		
	Noise(Away 4 Meters)(dBA)	75		
Generator	Charging Voltage(V)	12(DC)		
	Charging Current(A)	8.3		
	Cosφ	1		
	Rated Frequency(Hz)	50/60		
	Rated Voltage(V)	110/115/120/220/230/240		
	Rated Output(KVA)	1.3	2.0	2.3/2.5
	Maximum Output(KVA)	1.5	2.2	2.5/2.8
Generator set	Length(mm)	590		
	Width(mm)	430		
	Height(mm)	490		
	Net weight(kg)	42/44	45/47	46/47
Usual Accessory	Large Air Cleaner	●	●	●
	Large Muffler	●	●	●
	Large Fuel tank	●	●	●
	Fuel Gauge	●	●	●
	Voltmeter	●	●	●
	Automatic Voltage Regulator	●	●	●
	Oil Alarming system	●	●	●
	Non-fuse breaker	●	●	●
Battery Holder	- (●)	- (●)	- (●)	
Optional Accessory	Four wheel Vehicle Set	●	●	●

	Item	3800(D)-F	5000(D)-F	6500(D)-F	8000(D)-F
Engine	Engine Type	173F(D)	182F(D)	188F(D)	190F(D)
	Engine Mode	Single cylinder, Forced Air Cooling,4-Stroke,OHV25° inclined			
	Displacement(cc)	242	337	389	420
	Rated power(kW/3600rpm)	5.1	7.1	8.2	9
	Igniting Mode	T.C.I.			
	Fuel Volume(L)	25			
	Fuel consumption(g/ps.h)	≤374			
	Continuing Time(hr)	13	10	9	8
	Oil Volume(cc)	1100			
	Noise(Away 4M)(dBA)	≤76			
Generator	Charging Voltage(V)	12(DC)			
	Charging Current(A)	8.3			
	Cosφ	1			
	Rated Frequency(Hz)	50/60			
	Rated Voltage(V)	110/115/120/220/230/240			
	Rated Output(KVA)	2.8	4	5	6.0/6.5
	Maximum Output(KVA)	3.1	4.5	5.5	6.5/7.0
Generator set	Length(mm)	675			
	Width(mm)	540			
	Height(mm)	542			
	Net weight(kg)	70/72	78/81	83/86	87/90
Usual Accessory	Large Air Cleaner	●	●	●	●
	Large Muffler	●	●	●	●
	Large Fuel tank	●	●	●	●
	Fuel Gauge	●	●	●	●
	Voltmeter	●	●	●	●
	Automatic Voltage Regulator	●	●	●	●
	Oil Alarming system	●	●	●	●
	Non-fuse breaker	●	●	●	●
Battery Holder	- (●)	- (●)	- (●)	- (●)	
Optional Accessory	Four wheel Vehicle Set	●	●	●	●

Remarks: ● means available, - means unavailable

NOTE: Specifications are subject to change without notice.

The power rating of the engine indicated in this document is the net power output tested on a production engine for the engine model and measured in accordance with SAE J1349 at 3,600 rpm (Net Power) and at 2,500 rpm (Max. Net Torque). Mass production engines may vary from this value.

Actual power output for the engine installed in the final machine will vary depending on numerous factors, including the operating speed of the engine in application, environmental conditions, maintenance, and other variables.

12.OPTIONAL PARTS

I. BATTERY (battery frame inside)

Use a battery rated at 12V, 28AH or more.

NOTICE

Do not reverse polarity. Serious damage to the generator and/or battery may occur.

⚠ WARNING

A battery can explode if you do not follow the correct procedure, seriously injuring anyone nearby.

Keep all sparks, open flames, and smoking materials away from the battery.

Check the electrolyte level to be sure that it is between the marks on the case. If the level is below the lower mark, remove the caps and add distilled water to bring the electrolyte level to the upper mark. The cells should be equally full.

Battery Tray Kit

- ①. Install the battery guard on the frame.
Set the battery tray on the battery guard and tighten the bolts.
- ②. Route the starter cable under the tank and connect it to the starter solenoid.

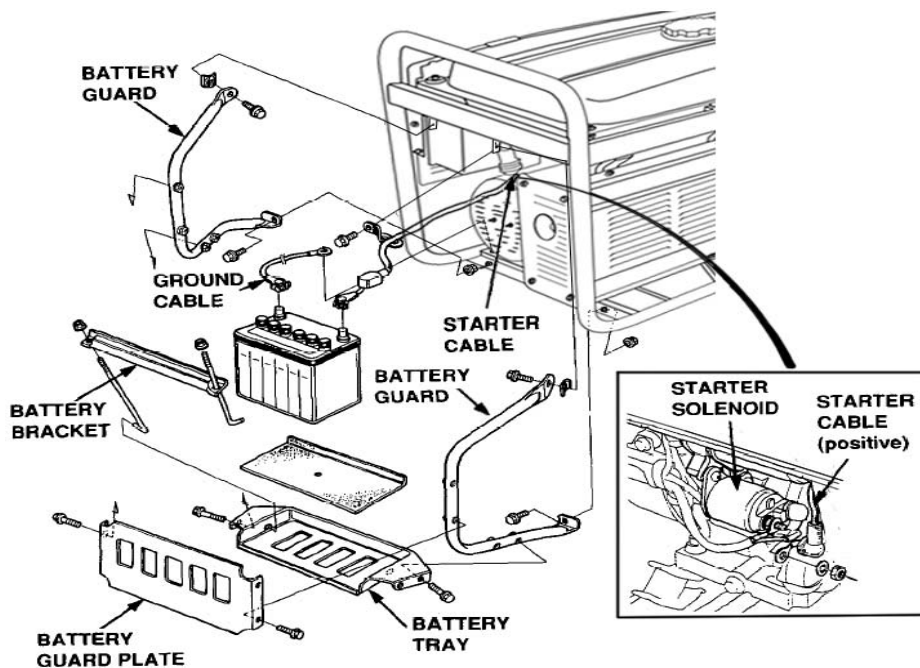

- ③. Connect the ground cable to the generator rear housing.
- ④. Set the battery on the battery tray and secure with the battery bracket.
Connect the starter cable to the battery positive (+) terminal first, then connect the ground cable to the negative (-) terminal. When disconnecting, disconnect at the battery negative (-) terminal first.
- ⑤. Install the battery guard plate on the battery guard.

II. BATTERY (battery frame inside)

Use a battery rated at 12V, 9Ah (for 3800D-F or less) and 14Ah (for 5000D-F or more)

WARNING

FILLING YOUR MAINTENANCE FREE BATTERY

FAILURE TO FOLLOW THESE INSTRUCTIONS PRECISELY MAY RESULT IN ACID DAMAGE TO CLOTHING, WORKTOPS AND MOTORCYCLE

THE MANUFACTURERS, DISTRIBUTORS AND SUPPLIERS ANNOT BE HELD RESPONSIBLE FOR ANY SUCH DAMAGE

1. Remove filler cap strip (where fitted) (Fig.1) from bottle, to expose silver sealed foils, do not remove the silver foils.
(Note: the bottle contains the exact amount of acid for the battery)
2. Line up the neck of the bottle with the battery filling holes (Fig.2)
3. Push bottle down into the holes piercing the seals and allowing electrolyte to flow into battery
4. When all the fluid has drained into the battery remove empty bottle and firmly press the sealer cap into position over battery vent holes (Fig.3)

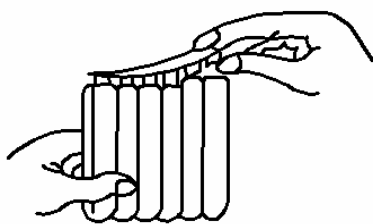

fig.1

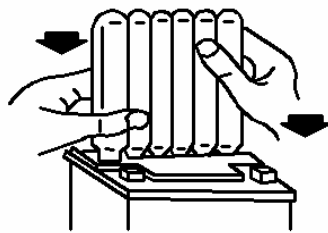

fig.2

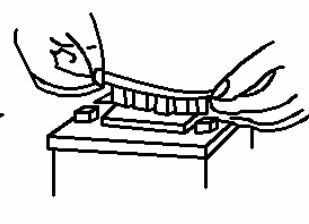
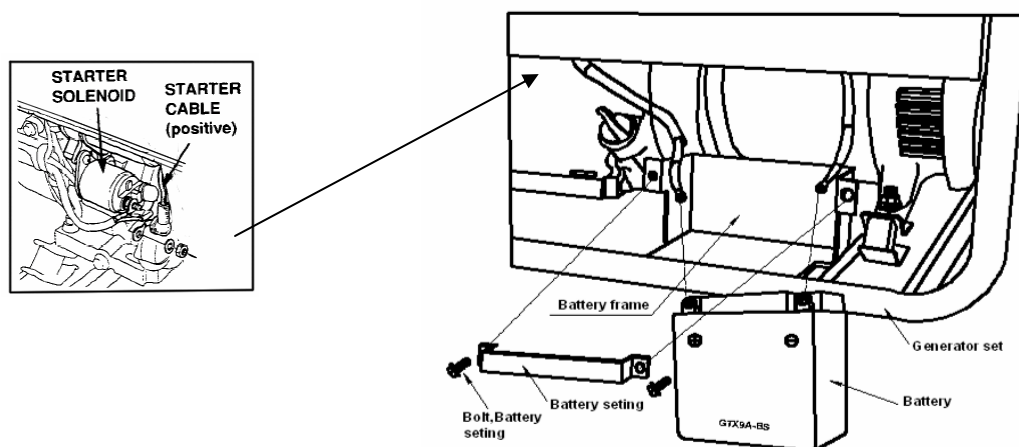

fig.3

Battery frame

1. Connect the starter cable to the battery positive (+) terminal first, then connect the ground cable to the negative (-) terminal. When disconnecting, disconnect at the battery negative (-) terminal first.
2. Set the battery on the battery frame.
3. Install the battery setting on the battery frame and secure with the bolt battery setting.



Wheel Kit Installation (II)

- ①. Install the two wheels on the axle shaft;
- ②. Install the axle assembly on the generator using four bolts(M8×16) and nuts(M8);
- ③. Install the rubber on the setting rubber using two bolts(M8×25) and nuts(M8);
- ④. Install the rubber shock absorber on the generator using four bolts(M8×16) and nuts(M8);
- ⑤. Install the pipe handle on the setting handle using two bolts(M6×40) and nuts(M6);
- ⑥. Install the handle comp. on the generator using four bolts(M6×40) and nuts(M6);

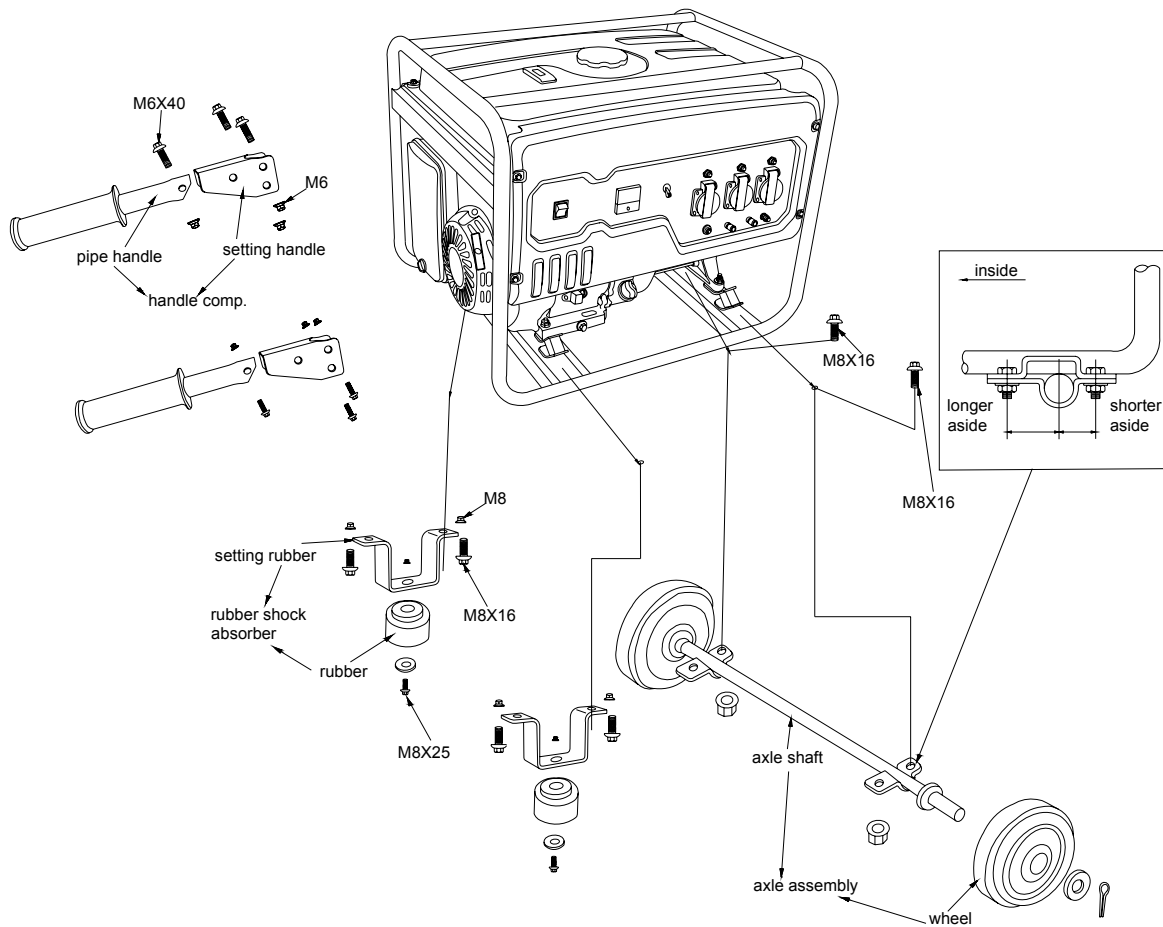



隆鑫通用动力股份有限公司
Loncin motor co., Ltd.

详细地址：重庆市九龙坡区九龙工业园区华龙大道99号

服务电话：023 8980 5678/8980 8505

传 真：023-8906 7566

邮政编码：400052

Email: marketing@loncinengine.com

Website: www.loncinengine.com

PRINTED IN CHINA