

LONCIN 隆鑫

General Power Products

Gasoline Generator

LC12000



Owner's Manual



Thank you for your purchasing our Electric Generator Set.

- Copy right our All rights reserve.
- It is prohibited from reproducing, transferring, distributing and memorizing any content in the manual without obtaining a written approval from our our in advance.
- Our abides by the continuous development strategy; therefore, Our reserves the right of modification of product and revision of the manual without any notice.
- Take this manual as a part of the Generator set. If the set is resold, it is required to transfer the manual with the set.
- This manual contains information how to correctly operate the generator set, read it carefully before using the set. Correct and safe operation will provide you with a great benefit.
- Our addresses itself to innovate and develop its products both in design and quality, therefore, the content in this manual may have slight difference to the real object, although it is the newest revised manual while it is pressed.
- Please contact with your retailer if you have any questions or doubts.

Safety warning

It is very important for the safety of your body and property and for that of the other persons. Please carefully read the information after the symbols  and .

They are the safe warning symbols to give you a warn or a prompt. The definition of the symbols are given below:

 **Danger** Extreme harm will occur, provided your operation does not follow the information after the symbol.

 **Warning** Severe harm will occur, provided your operation does not follow the information after the symbol.

 **Caution** Slight harm will occur, provided your operation does not follow the information after the symbol.

 **Note** Damage to generator set or other property will occur, provided your operation does not follow the information after the symbol.

Content

1. Safety notice.....	1
2. Part and component names.....	3
3. Operation system.....	4
1) Engine switch.....	4
2) Fuel valve.....	4
3) Choke button.....	5
4) AC circuit breaker.....	5
5) Grounding terminal.....	6
6) Engine oil protection system.....	6
4. Use of generator.....	7
1) Connecting to power supply.....	7
2) Generator grounding.....	8
3) Alternating current.....	8
4) Control at high elevation.....	9
5. Check before operation.....	10
1) Engine oil.....	10
2) Fuel.....	11
3) Battery.....	11
6. Start engine.....	12
7. Stop engine.....	12
8. Maintenance.....	12
1) Replace engine oil.....	13
2) Maintain air cleaner.....	14
3) Clean fuel filter.....	15
4) Spark plug.....	16
9. Storage.....	17
10. Troubleshoot.....	18
11. Wiring diagram.....	19
1) 12000 1-phase diagram.....	19
2) 12000 3-phase diagram.....	20
12. Powered starting assy.....	21
13. Parameters.....	22

1. Safety notice

Before operating the generator, it is required to read the manual carefully and understand it, It is helpful to prevent you from accidental injury that you must be familiar with the safety procedures of the generator set.

Never use it indoor



Never use it in damp environment

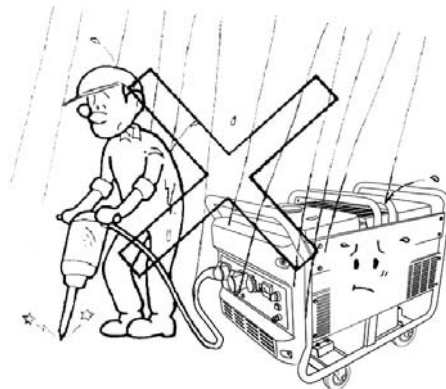

Never connect it direct to power supply

Keep it 1m away from inflammable thing

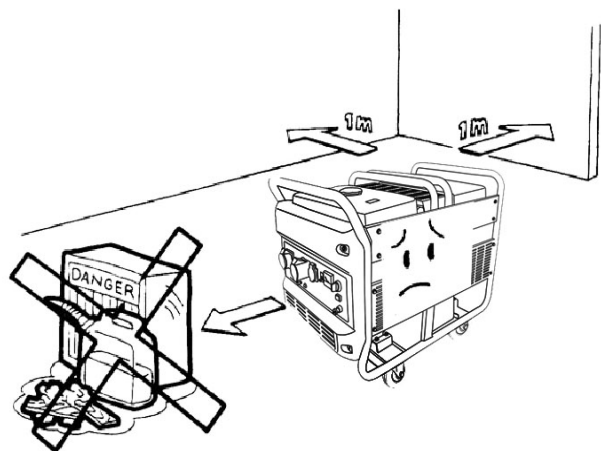

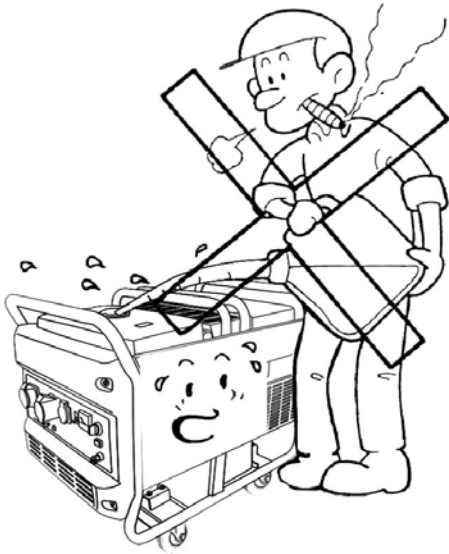

Don't smoke, while filling fuel

Don't overfill fuel

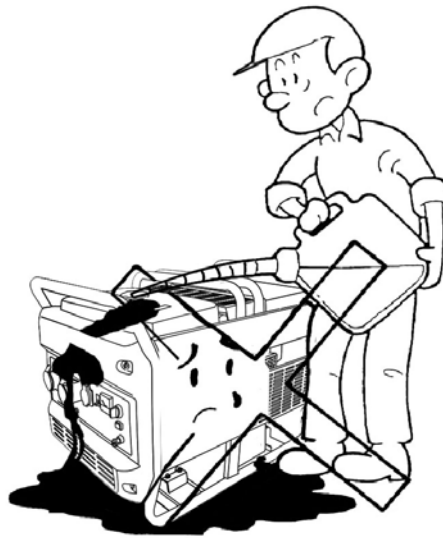

Stop engine before filling fuel

2. Part and component names

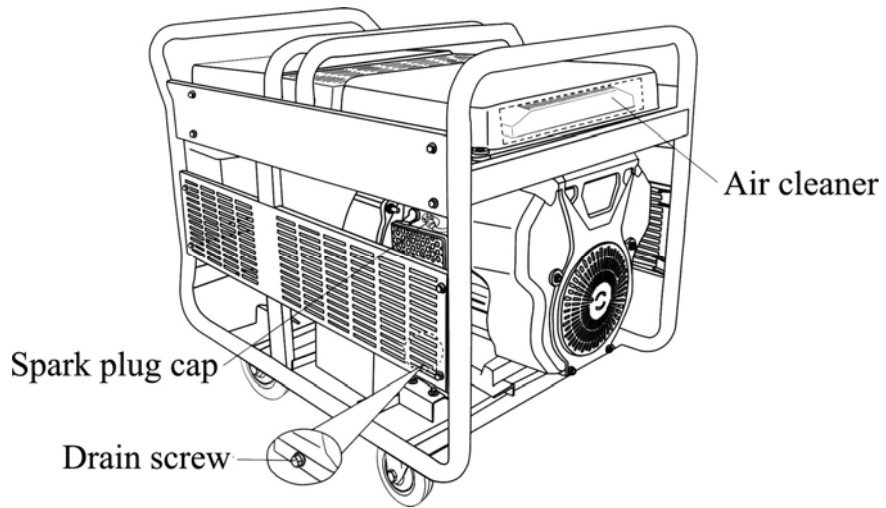
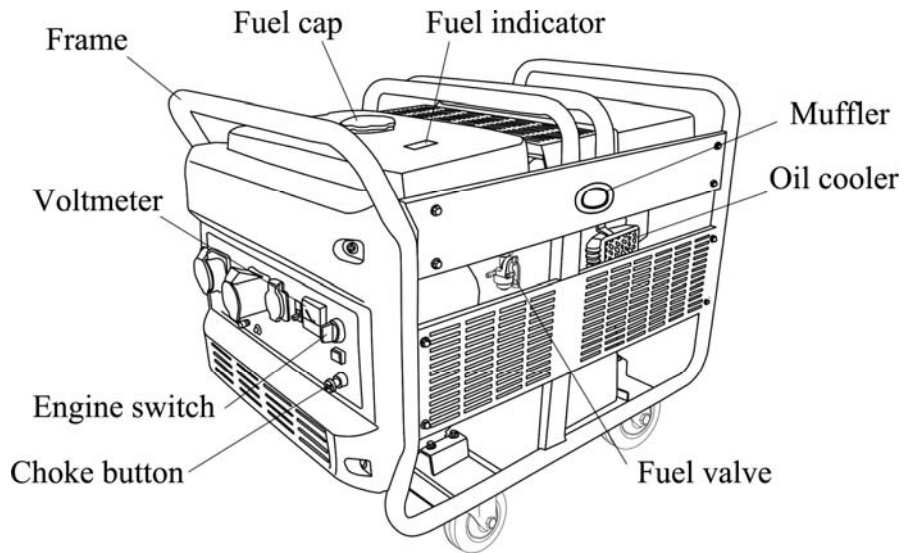

3. Operation system

1) Engine switch

“RUN” indicates the engine in “Run ” position, “OFF” indicates the engine in “OFF” position, “START” indicates the engine in “starting” position.

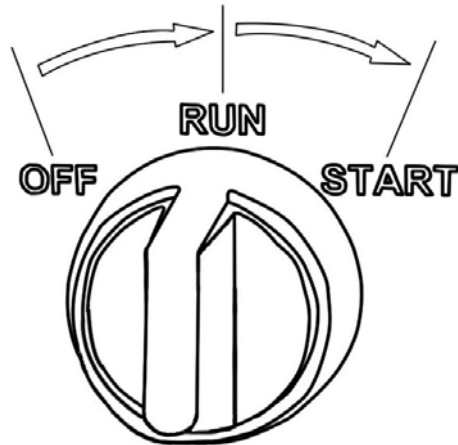

Note The battery is working for the carburetor valve at “RUN” channel. So please make sure the switch is at the “OFF” channel when the unit is turn off.

2) Fuel valve

The fuel valve is used to control the fuel flow from the tank to the carburetor. After stopping the engine, the fuel valve should turn to “Off” position.

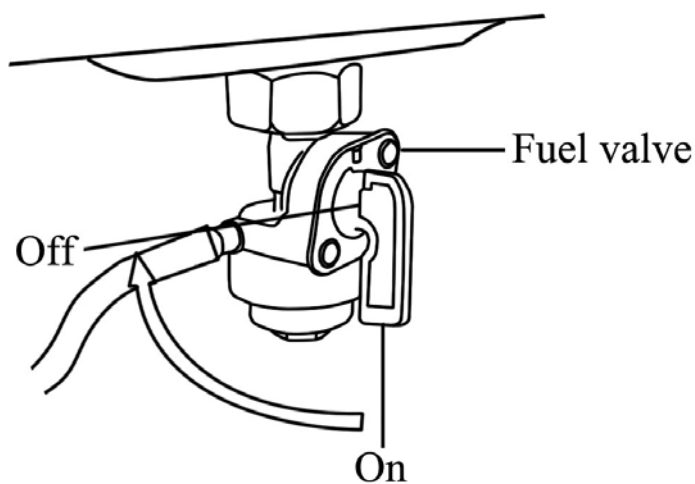

3) Choke button

The choke button is used to provide mixed gas with rich fuel to the engine when it is in cold start. When the engine runs normally, push it to “open” position.

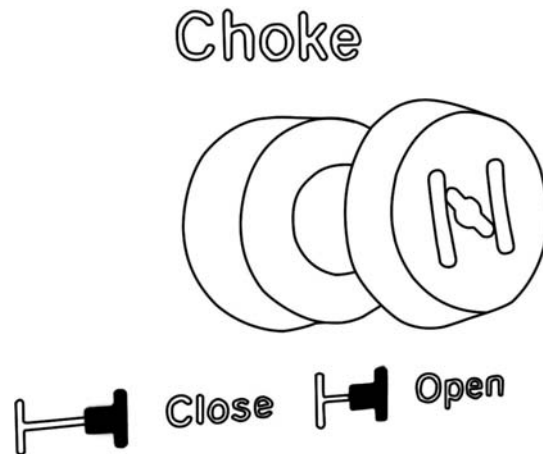

4) AC circuit breaker

The overload current will make the circuit breaker trip out automatically. It is required to prevent the generator set from short circuit or overload. If the circuit breaker trips out, do not turn on the circuit breaker before checking the load and short circuit.

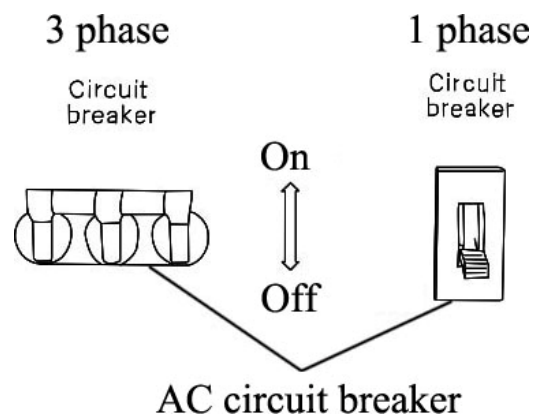

5) Grounding terminal

The grounding terminal is a special terminal which is used to connect the generator to the ground properly.

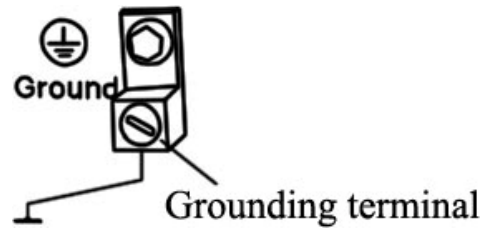

6) Engine protecting system

The engine protecting system is designed to protect engine from damage because of lack of oil in the crank case. When the engine oil in crank case is lower than the safe level line, the engine protecting system will work to stop the engine automatically (even the engine switch is still in “run” position). Thus, the engine may not be worn out because of lack of oil.

4. Use of generator

Environmental requirement for use of the generator:

- Serviceable temperature: $-15^{\circ}\text{C} \sim 40^{\circ}\text{C}$
- Serviceable humidity: 95% below
- Serviceable elevation: in area below 1000 m, (If using it in the area over 1000 m, the rated power will degrade.)

1) Connect to power supply

Note When the generator is taken as a backup power supply to connect with the household appliances, only the electrician or authorized person can do this job. After connecting the load to the generator, careful inspection must be performed for reliable connection and safety. It will result in damaging or burning out the generator or firing because of incorrect connection.



Good



Prohibited

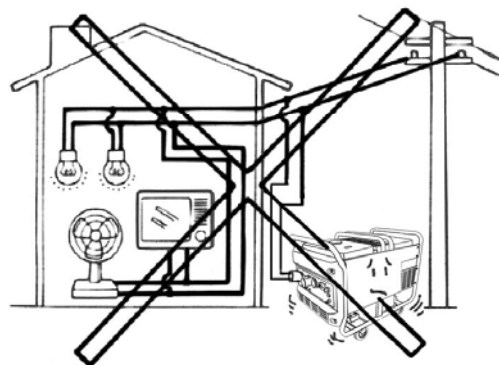
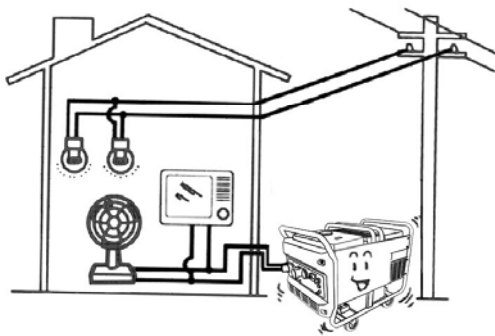

Good

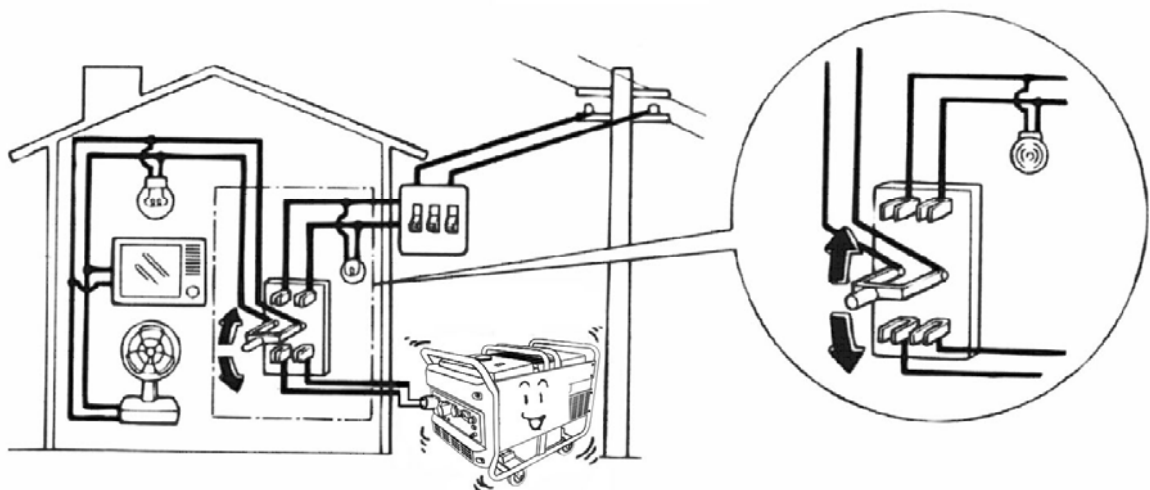

2) Generator grounding

To prevent the electric shock from the poor-quality appliances or from incorrect use of appliances, it is necessary to connect the generator to the ground with an insulated wire.

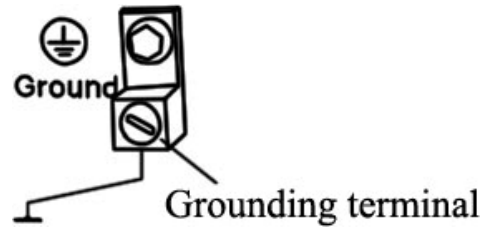

3) Alternating current

Before starting the generator, it must confirm:

The total power of the appliances does not exceed the rated power of the generator.





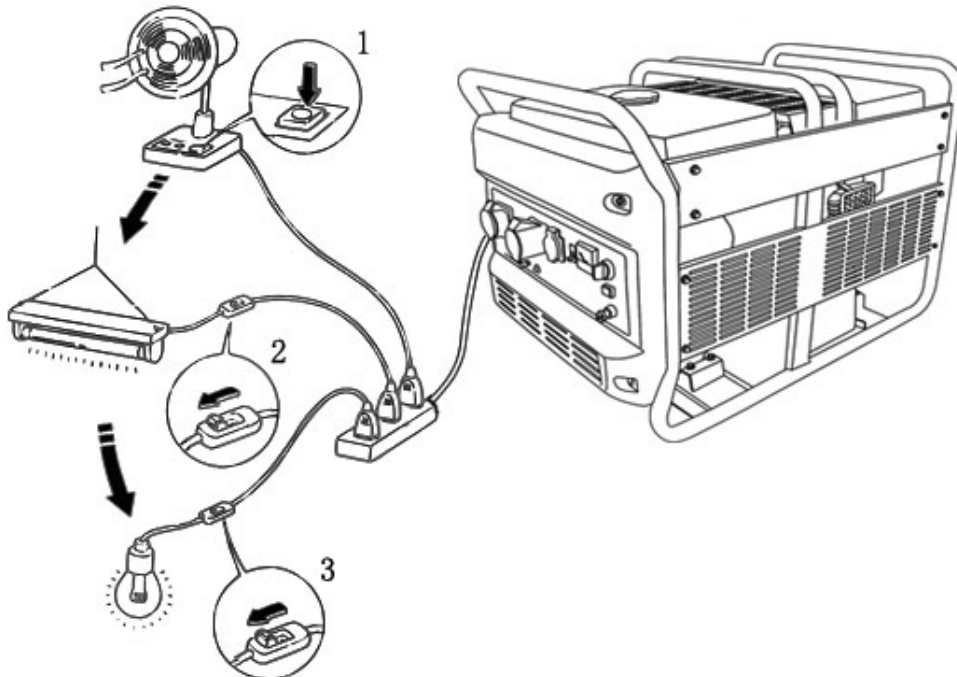



Note Overloaded use will shorten the service life of the generator set.

Keep firmly in mind that if the generator set connects with several loads or appliances, it is recommended to turn on the appliance with the maximum current first, then turn on that one with the secondary current, at last, the one with the minimum current.

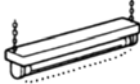

In general, the capacitive load or inductive load will need great starting current, when it

turns on, specially the motor actuating device. The following table indicates the parameter of the appliances for your reference:

Type	Watt		Typical appliances	Example		
	Starting	Rated		Appliances	Starting	Rated
<ul style="list-style-type: none"> ● Filament lamp ● Heater 	X1	X1	 Filament lamp  TV set	 Filament lamp 100W	100VA (W)	100VA (W)
● Fluorescent lamp	X2	X1.5	 Fluorescent lamp	 40W Fluorescent lamp	80VA (W)	60VA (W)
● Motor actuating device	X3~5	X2	 Refrigerator  Electric fan	 Refrigerator 150W	450~ 750VA (W)	300VA (W)

4) Use at high elevation

In high elevation area, the standard carburetor will make overrich mixed gas to the engine, thus, the output power degrades, and the fuel consumption increases. By reinstalling an orifice with smaller diameter or regulating the fuel supply screw, the working condition of the engine can be improved. If you usually use the engine in the high elevation area (over 1000m), it is recommended to replace the carburetor in the authorized retailer.

Even installing the proper carburetor, the engine power will degrade about 3.5% every 300m by increment of elevation. If installing improper carburetor, the power will degrade further.

Note If the carburetor for high elevation is used in low elevation area, the situations of engine power degraded, engine overheated or engine damaged severely may occur because of rarefied mixed gas.

5. Check before operation

1) Engine oil

Note At each time of using the generator, check the oil level in the condition of placing the generator at a level ground, and the engine staying in stop. The engine oil is an important factor for the output power and service life of the engine. If the contaminated oil or 2-stroke oil is used, it will harm the engine.

Recommended engine oil:

Engine oil for 4-stroke engine:

API classification: SE、SF or equivalent to SC

SAE 10W-30.

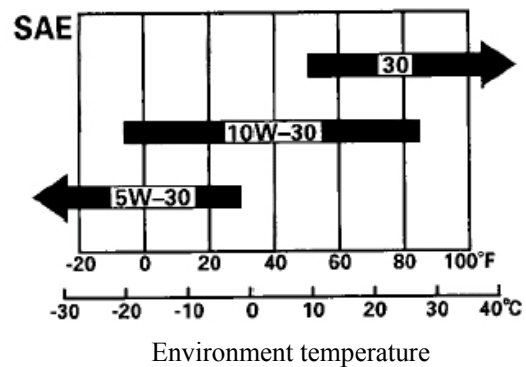

Checking method of engine oil level:

Pull out the oil ruler and clean it. Plug in the ruler thoroughly and take it out again to check the oil level.

If the oil level is lower than the low limit, remove the filler cap (the cap on the head facing to the ruler) and fill the recommended oil till it goes up to the top limit.

After filling oil, keep firmly in mind to reinstall the ruler and tighten the cap.

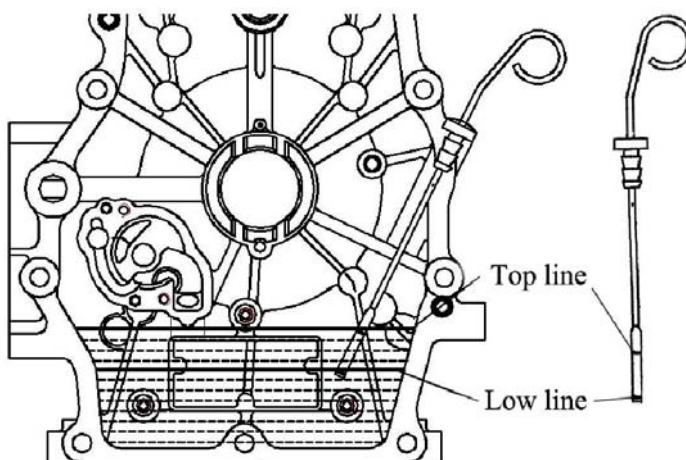

2) Fuel

- 1). Check the fuel level from the fuel indicator.
- 2). If the fuel level is low, unscrew the tank cap, fill fuel till it reaches the shoulder of fuel filter.
- 3). After filling fuel, install the cap and tighten it..

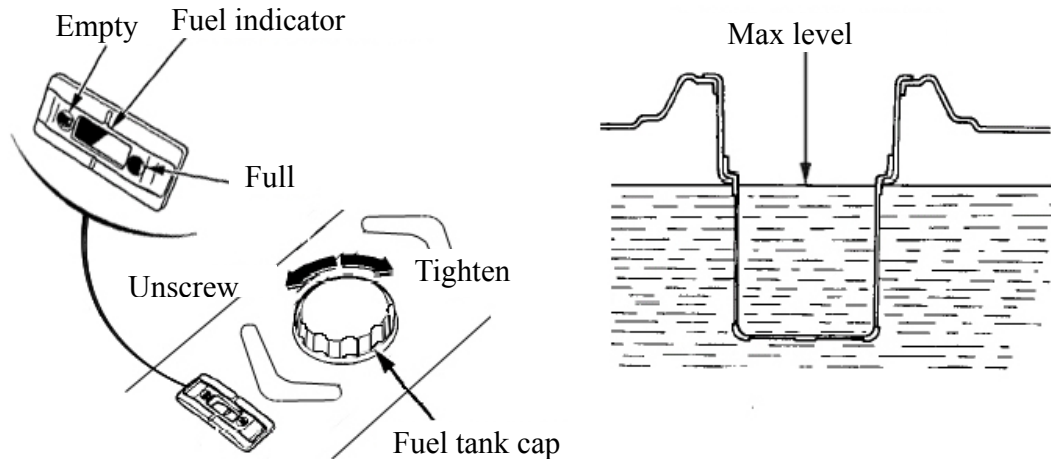

! Warning

- **After stopping the engine, fill fuel in good ventilating area. Keep firmly in mind that it is prohibited to smoke and flame around the area. Never overfill fuel at any time.**
- **Prevent skin from contacting with fuel and avoid inhaling fuel vapor.**
- **Prohibit children from contacting fuel.**

It is recommended to fill lead free petrol, grade No 90 or higher.

When use lead free petrol, carbonized dirt is less, thus it can prolong the service life of exhaust system.

It is prohibited to use waste fuel, contaminated fuel and fuel mixed with engine oil.

Avoid dust or water into the fuel tank.

3) Battery

Please choose the battery, 12V, rated capacity of 20Ah or more.

Note **Never connect the positive and negative electrodes in reverse, otherwise, it will damage the engine and battery severely.**

Check the electrolyte level in cell if they are in the position between the top limit line and low limit line. If the electrolyte level is lower the low limit line, screw out the cap and fill distilled water till it rises up to top limit line. All electrolyte level in cells should be almost in the same height.

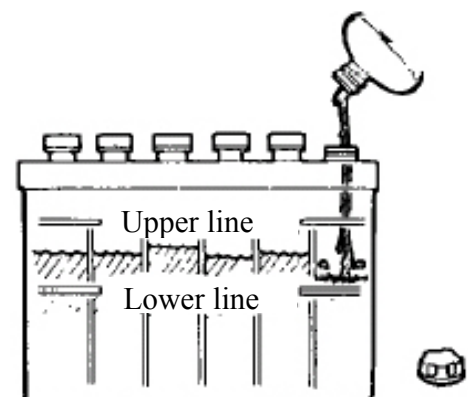



If operate improperly, the battery may explode, thus, injury may occur to the persons around, therefore, keep the smoke and flame and inflammable things away from the battery. The battery will release explosion gas, keep the fire away from it. When charge the battery or use the battery, keep ventilating.

6. Start engine

Powered start

- 1) Remove all loads on the terminals.
- 2) Open the fuel valve.
- 3) Turn off the AC circuit breaker.
- 4) Pull the choke button to “close” position.

Note When the engine is in warming condition, do not close the choke.

- 5) Turn the start switch to “start” position.
- 6) After starting the engine, release the “start ” switch immediately, the switch will return back to “run ” position.
- 7) After warming up the engine, push the choke button to “open” position.

Note

- **Do not let the switch stay in “start” position over 5 seconds, or the starter may be damaged. If the engine can not be started at first time, start the engine again at an interval of over 10 seconds.**
- **If the starter speed degrades after using it a period of time, it means charging the battery is necessary.**

7. Stopping engine

- 1) Turn off the AC circuit breaker.
- 2) Turn off the engine switch.
- 3) Close the fuel valve.

Note If an emergency stop is necessary, turn off the engine switch directly.

8. Maintenance schedule

Good maintenance and service gives an assurance that the generator runs in safety and economy and without any failures, in the meanwhile it is in favor of environment protection.



Warning

There is carbon monoxide in the emission of the engine, do not maintain the engine before stopping it. If it must maintain during the engine running , it is required to do it in good ventilation.

Periodical maintenance and service ensures that the generator runs in good condition. The periodical maintenance schedule indicates as follows:

Periodical maintenance schedule		Every time	20 hours or the first month (3)	50 hours or every 3 month (3)	100 hours or every 6 month (3)	300 hours or every year (3)
Engine oil	Oil level	○				
	Replace		○		○	
Fine oil filter	Replace					○(2) or 200 hours
Air cleaner	Check	○				
	Clean			○(1)		
Fuel filtering cup	Clean				○	
Electrolyte level of battery	Check	○				
Spark plug	Clean				○	Replace
Valve gap	Regulate					○(2)
Fuel tank & screen	Clean	Every 2 years (2)				
Fuel pipe	Replace	Every 2 years (2)				

- 1) Maintain the engine more frequently in use of dusty area.
- 2) The maintenance should be performed by the aid of manufacturer's franchised dealer.
- 3) If the generator is used frequently, it is required to maintain it according to the period stated above so as to ensure the service life of the generator.



Warning

Improper maintenance or the generator running with troubles will cause harmful default. Please check the generator in accordance with the manual instruction and maintain it in time.

1) Replace engine oil

After warming up the engine, it is easy to drain the engine oil and ensure the engine oil is rapidly drained out.

-
- 1) Place a container under the engine for containing used oil. Then, remove the oil ruler and loosen the draining screw and washer,.
 - 2) After drainage of used oil, reinstall the draining screw and washer and tighten them. In view of environmental protection, please take a proper way to dispose the waste oil. It is recommended to send the waste oil to the local service station or recycle center. Never throw waste oil barrel to refuse tip, dump the waste oil on ground or in ditches.
 - 3) Place the engine in level position, refill recommended oil to the top line.

The filling capacity of the engine:

Not replace the fine oil filter: 1.3L

Replace the fine oil filter: 1.5L

- 4) Reinstall the oil ruler and tighten filler cap.

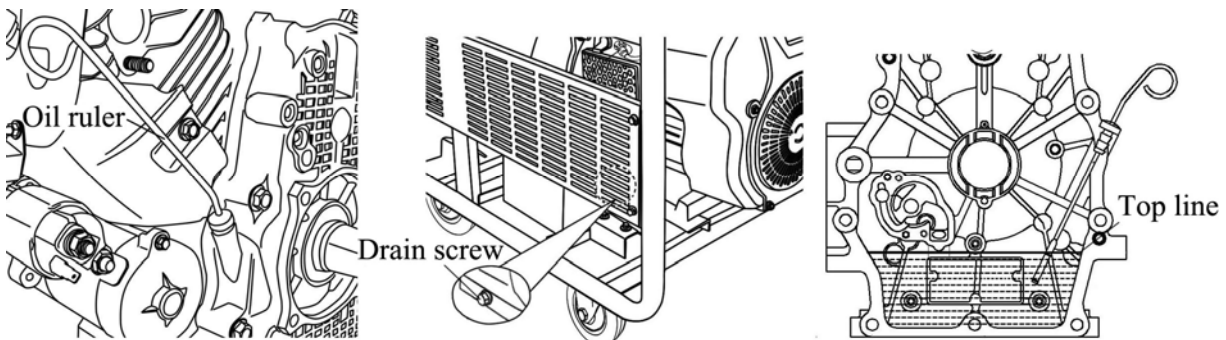

Caution If the skin touches the engine oil frequently in long term, it may result in skin cancer. Although it is not inevitable, we recommend to clean your hands with soap water thoroughly.

2) Maintain air cleaner

If the air cleaner is dirty, it affects air inlet, the power of engine reduced. If the running place is dusty, maintenance must be done more frequently than that shown in maintenance schedule.

Warning It is prohibited to clean the air cleaner element with gasoline or inflammable solvent otherwise fire or explosion may occur, instead, clean it with soap water or nonflammable solvent.

Note

It is prohibited to run the engine in the case of no element or it results in rapid wear of the engine.

- 1) Unscrew the cap nut, and remove the case.
- 2) Remove the washer, take out the paper and foam elements.
- 3) Separate the paper element from the foam one.
- 4) Check the elements and replace if necessary. As a rule, when reaching the period specified in maintenance schedule, replace the paper element

Clean paper element:

Strike the element several times to remove dust deposited on it or blow out with high pressure draft (less than 2.1 kg/cm^2), from inside to outside of the element, Never remove the dust with brush, or the dust will enter the fiber and block the vent holes..

Clean foam element:

Clean the foam element with soap water, rinse and dry it or clean it with high fire-point solvent and dry it.

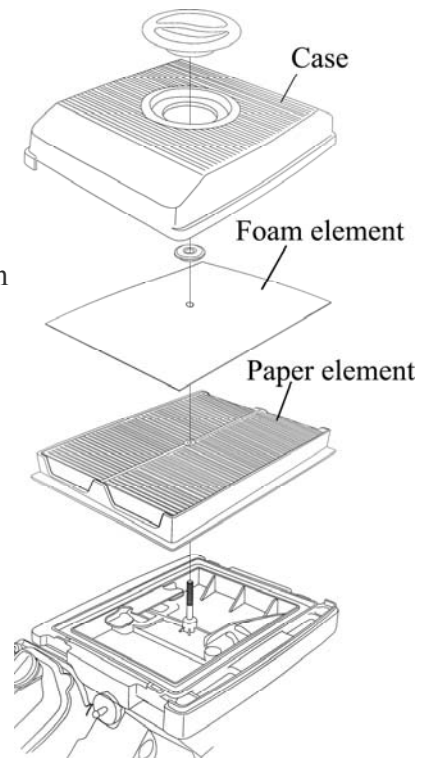

- 5) Clean air cleaner bracket and case. Prevent dust from sucking into the carburetor along the inlet pipe.
- 6) Assemble the foam element and paper element.
- 7) Install the case and tighten the cap nut.

3) Clean fuel filtering cup

- 1) Close the fuel valve. Detach the depositing cup and remove the “O” ring and screen.
- 2) Clean the depositing cup, the “O” ring and screen with unflammable or high flash-point solvent.
- 3) Reinstall the “O” ring and the screen, tighten the cup.
- 4) Open the fuel valve to check if there is any leakage.

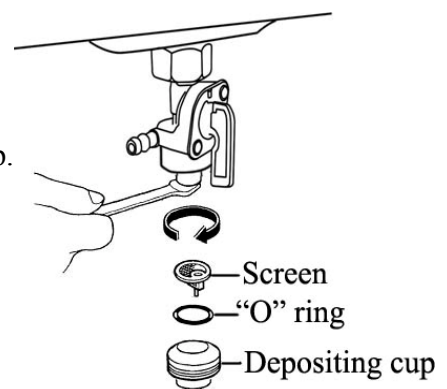

4) Spark plug

It is recommended to use spark plug, F7TC or equivalent one.

- 1) Remove the spark plug cap
- 2) Clean dust around the spark plug.
- 3) Unscrew the spark plug with a special socket wrench.
- 4) Check spark plug. If the electrode has damaged, or isolator has broken, replace the spark plug. The clearance of the spark plug electrode should be 0.70-0.80mm. Adjust the side electrode, if necessary.
- 5) Screw the spark plug with hand carefully to avoid damaging the thread on the head.
- 6) When the spark plug is in position, tighten the spark plug with the special socket wrench and depress the washer.
If install the used spark plug, after depressing the washer, retighten it 1/8-1/4 turn.
- 7) Reinstall the spark plug cap.

Note

Please use the spark plug with a proper heat rating.

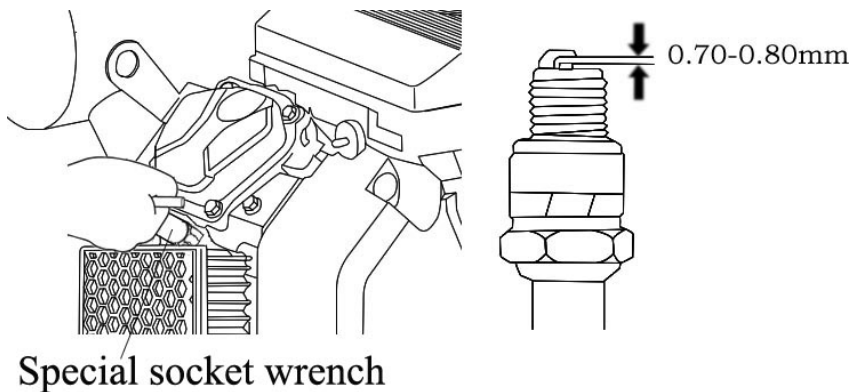

9. Storage

⚠ Warning To avoid burn or fire by contacting with the heated parts of the engine, never pack and store the engine till it is cool enough.

- 1) If the engine will be stored for a long term, it must keep the storing area clear and dry. Drain out the fuel in the tank. Clean the fuel filtering screen, “O” ring and depositing cup, then reassemble them. Unscrew the draining screw of the carburetor, drain the fuel in the carburetor from the overflow pipe to the container.

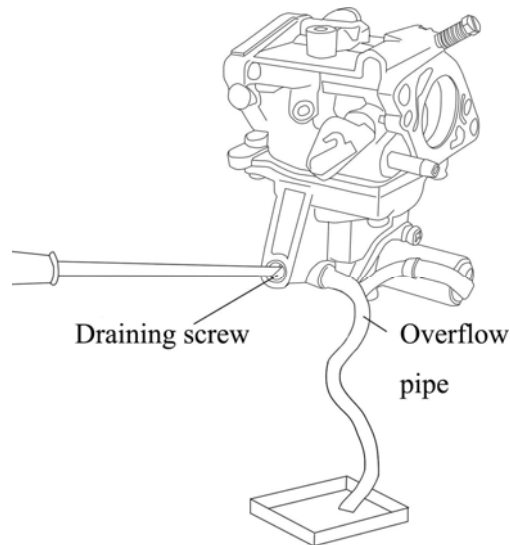

⚠ Warning As a ruler, gasoline is an inflammable and explosive liquid. After stopping the engine, drain fuel in ventilating condition. Prohibit firing and smoking during drainage.

- 2) Remove the oil level ruler, unscrew the draining screw and drain out the engine oil in crankcase. Tighten the draining screw, fill fresh oil to the top line, then reinstall the ruler.
- 3) Remove two spark plugs, fill 5 lm-10 lm oil (a spoon of oil) in the combustion chamber. Rotate the crankshaft in several turns to scatter the oil in the head, then reinstall the spark plugs.
- 4) Rotate the engine slowly till a drag is felt. In such case, all valves are closed to prevent the humidity from air into the head.
- 5) Place the generator set in dry and ventilating area.

10. Troubleshoot

Engine does not start:

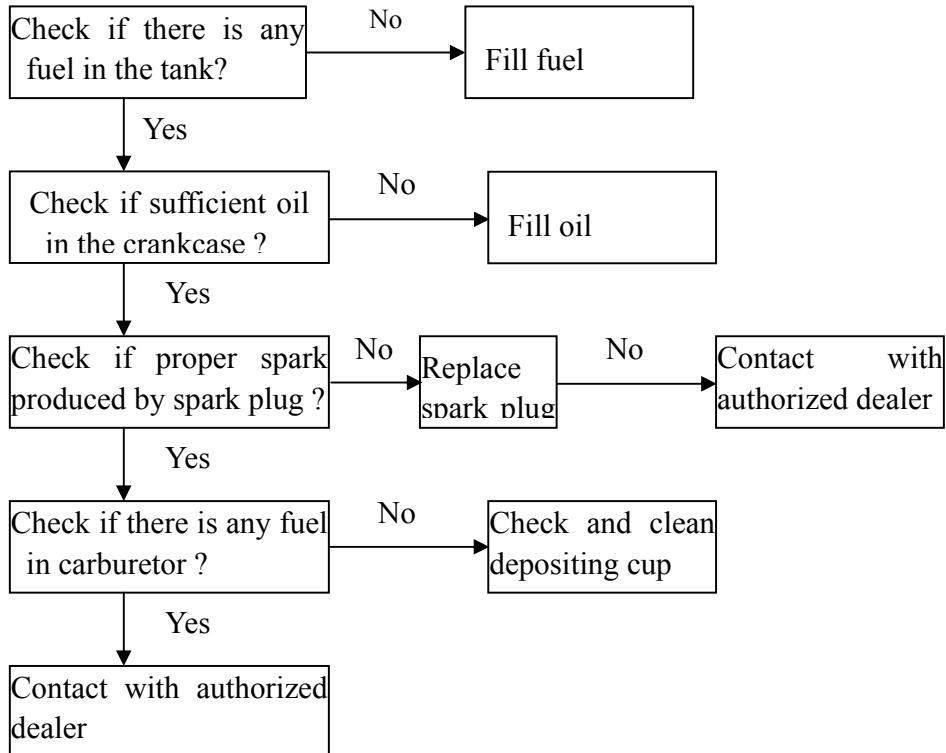

No voltage:

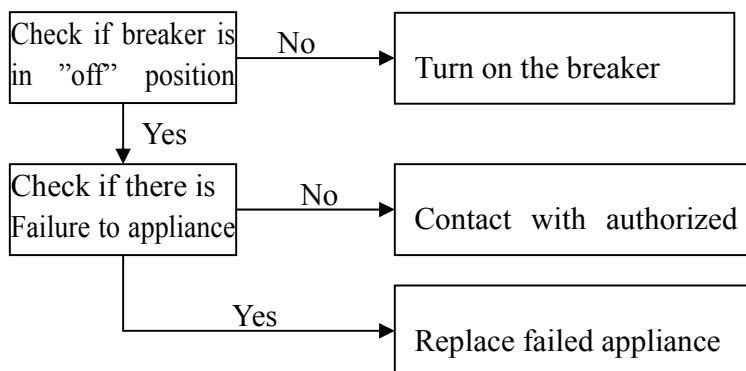

11. Wiring diagram

1) 12000 1-phase diagram

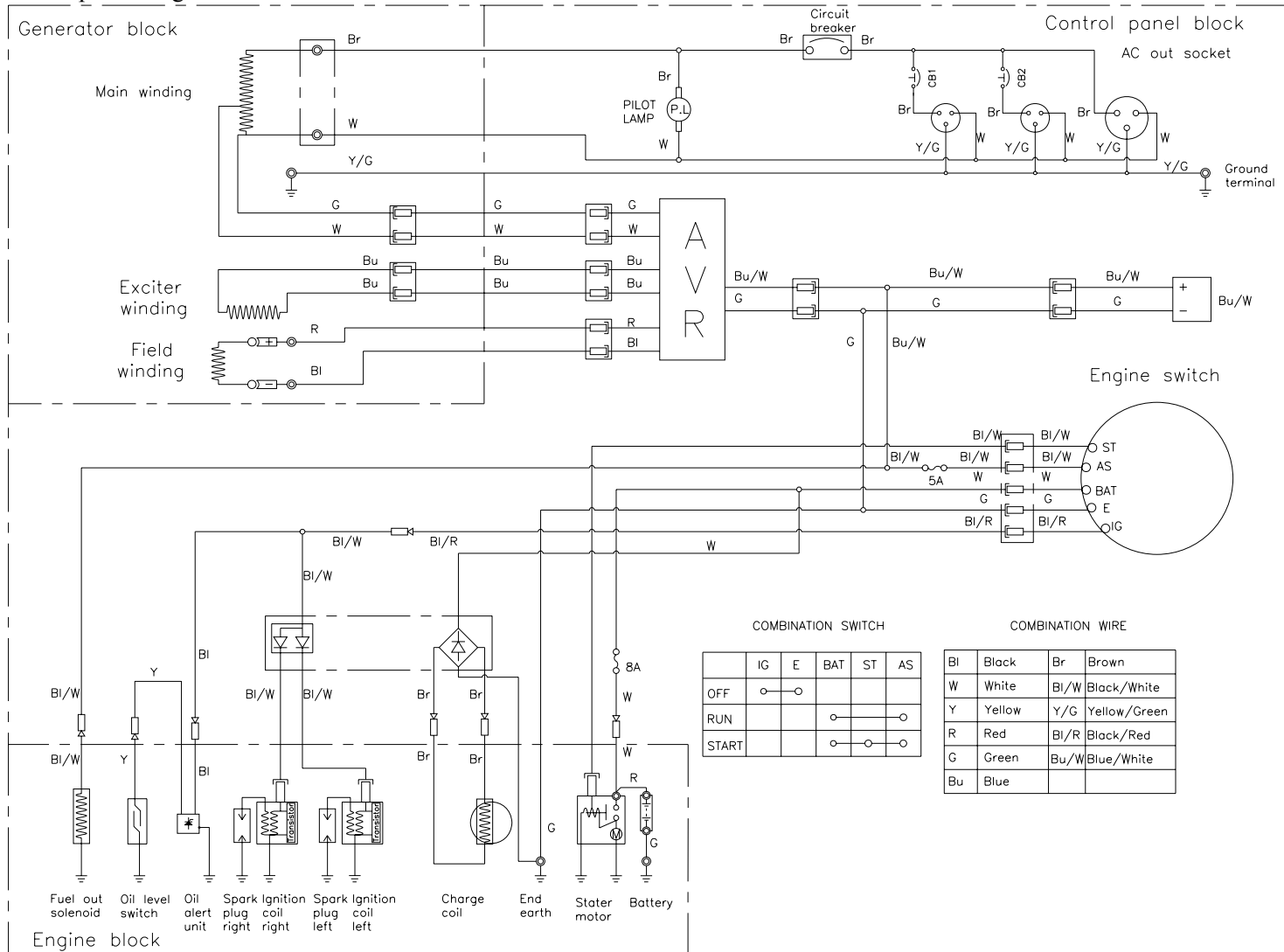

2) 12000 3-phase diagram

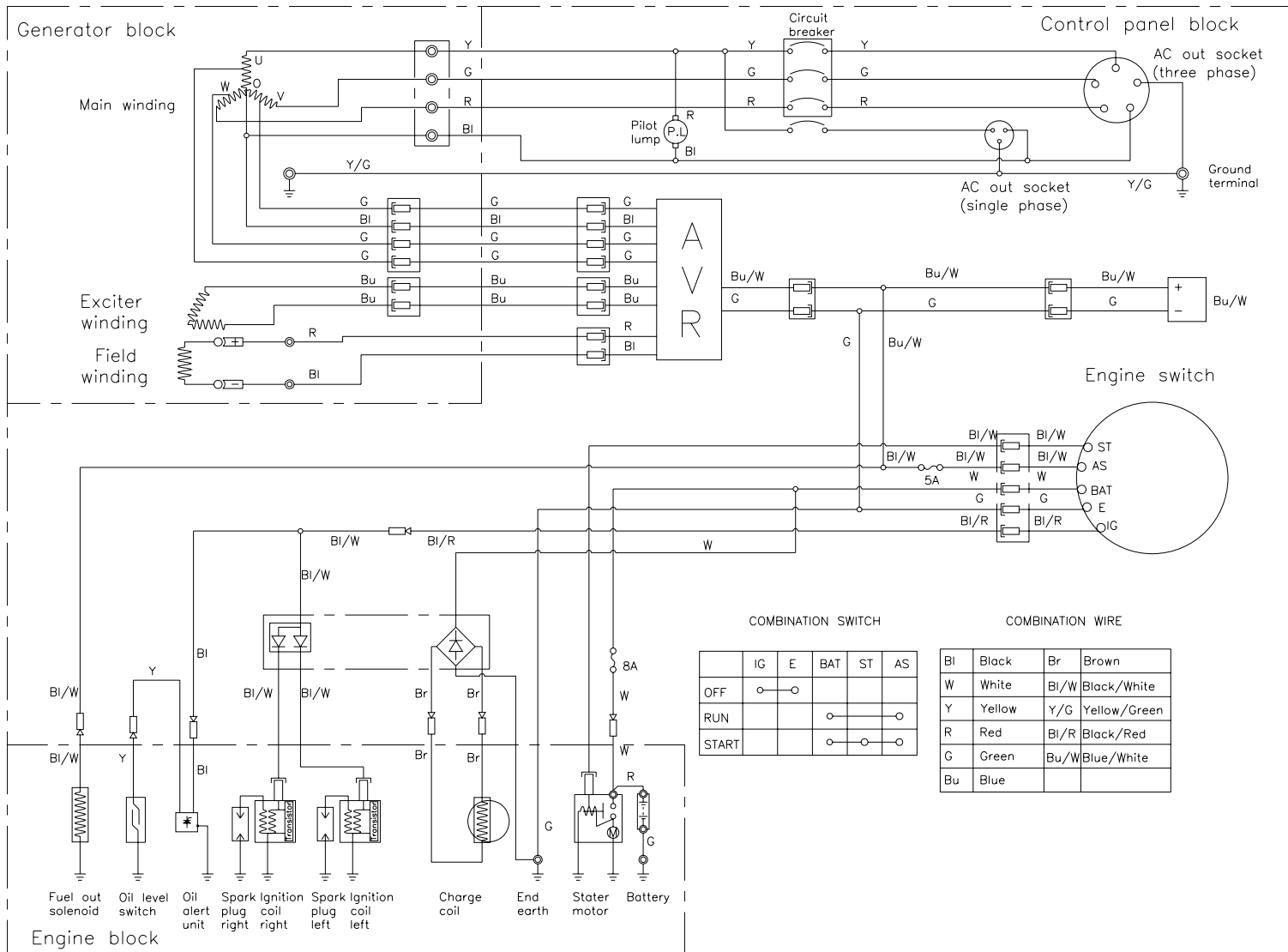

12. Powered start assy.

1) Pass the powered starting wires through the engine mounting frame and connect it to the starting battery switch.

2) Connect the grounding wire to the terminal at the end of the generator.

3) Place the battery into the lateral bracket, and fasten the battery with a fixture, then tighten the screws.

Connect the powered starting wire to the positive terminal of the battery, then connect the wire to the negative terminal. After loosening the wire, remove the wire from the negative terminal, then remove it from the positive one.

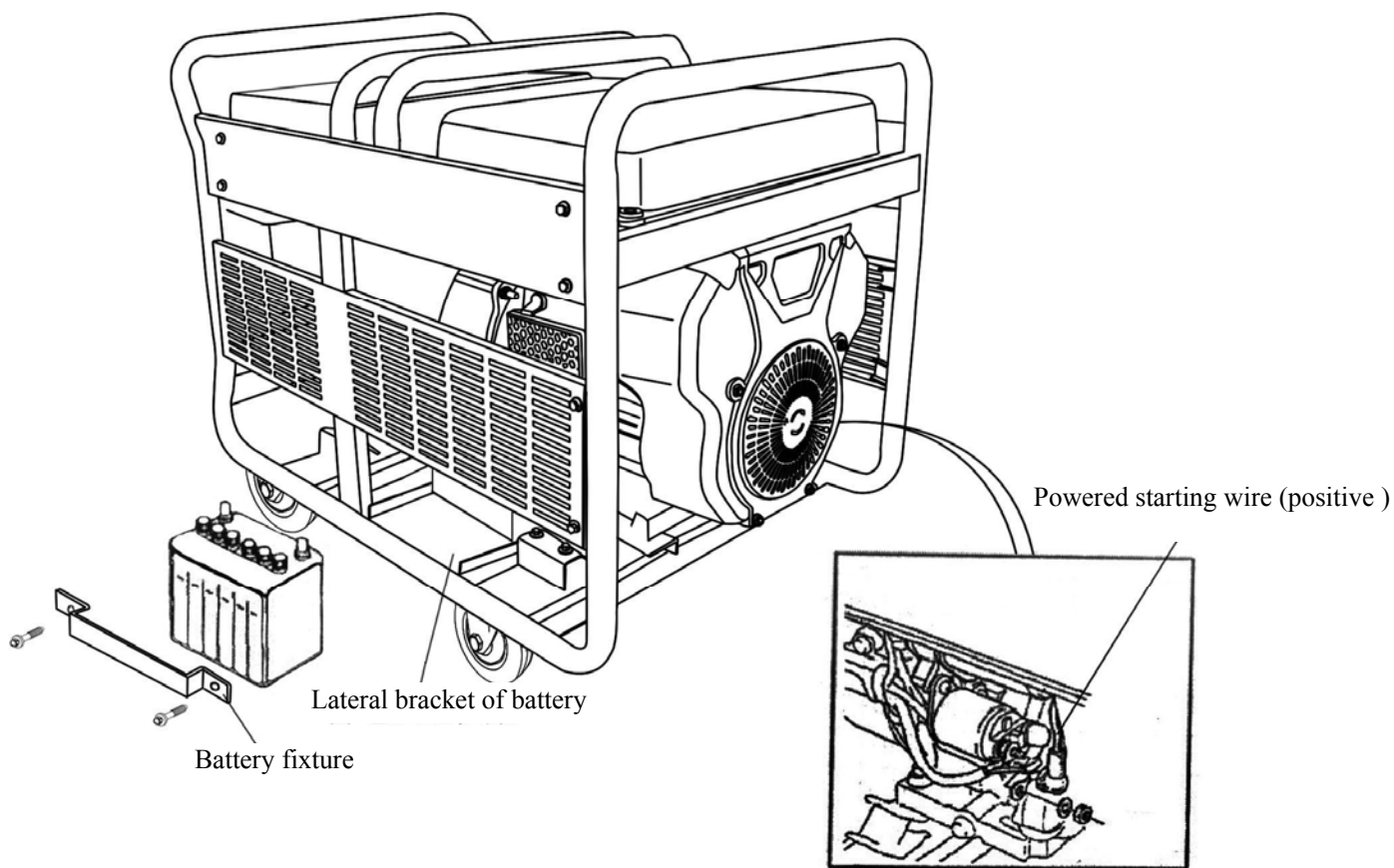

13. Parameters

	Project	12000			
Engine	Model	2V78F-1			
	Type	2-cyl、4-stroke、forced air cooling			
	Bore × stroke mm	78×71			
	Displacement ml	678			
	Compressed rate	8.5:1			
	Rated power kW/(r/min)	13.4kW/3600			
	Max torque N•m/(r/min)	42/ 2500			
	Ignition mode	Thyristor no-contact ignition			
	Start mode	Powered start			
	Lubricant capacity L	1.5			
	Fuel capacity L	25			
	Air cleaner element	Paper, foam element			
	Generator	Type	Synchronous generator		
Volt regulation		Automatic voltage regulation			
Rated voltage V		220/230/240		220/380 230/400 240/415	
Phase		1 phase	1phase	3phase	3 phase
Rated power kW		8.5	9.5	9	10
Max power kW		9.5	10.5	10	11
Rated frequency Hz		50	60	50	60
Power factor cosΦ		1.0	0.8	1.0	0.8
Generator set	Fuel consumption g/kW.h	≤360			
	Continuous working time h	6			
	Noise (7m away from generator set) dB (A)	≤70			
	Standard configuration	Fuel tank, muffler, air cleaner, fuel indicator, multiple-purpose meter, lubrication warning system of generator set			
	Dimension (L×W×H) mm	896×635×790			
	Net weight Kg	160			

The power rating of the engine indicated in this document is the net power output tested on a production engine for the engine model and measured in accordance with SAE J1349 at 3,600 rpm (Net Power) and at 2,500 rpm (Max. Net Torque). Mass production engines may vary from this value.

Actual power output for the engine installed in the final machine will vary depending on numerous factors, including the operating speed of the engine in application, environmental conditions, maintenance, and other variables.



隆鑫通用动力股份有限公司
Loncin motor co., Ltd.

详细地址：重庆市九龙坡区九龙工业园区华龙大道99号

服务电话：023 8980 5678/8980 8505

传 真：023-8906 7566

邮政编码：400052

Email: marketing@loncinengine.com

Website: www.loncinengine.com

PRINTED IN CHINA