

LONCIN 隆鑫

General power products

850 Mini Tiller

Tiller Owner s Manual

1WG3.4-85FQ-Z



www.loncinengine.com

Loncin motor co.,ltd.

Foreword

Thank you for purchasing our mini tiller

It is the accelerator for your building of a richer life.

With a small size, a light weight, multiple functions, high rotary tilling efficiency, ability to work on mountains, in waters, to cross ridges of fields and ditches, and easy transport and operation of turning around, this model of mini tiller is especially suitable for work in mountain areas, hilly areas, arid fields, irrigated fields, orchards, gardens, arch-roofed sheds, etc.

Its basic functions include rotary tilling, trenching, ridging and transportation. With the help of appropriate accessories, it can also used for pumping, irrigation, insecticide spraying, harvesting, power generating, fertilizing, seeding, seed extraction, threshing, climber cutting, grinding to produce thick liquid, etc., besides, it is simple in structure, easy to maintain and repair, and fuel-efficient, all these features make it an ideal mini farming machine.

It is a good helper for building a richer life of your family.

Warning! Unauthorized reproduction of this manual or any part of it for any other purpose is prohibited; when the mini tiller is resold, this manual, as part of the mini tiller, shall be transferred with the mini tiller.

Warning! Please pay special attention to the following information:

Please read carefully this operation and maintenance manual before operation and strictly comply with the manual while operating. If you operate in compliance with the manual, the mini tiller designed by our company can work safely and reliably without damage to equipment and personal injury. Should you not operate in compliance with the manual, there may occur severe damage or injury to your equipment or your body.

Note! Should there be any problem with the machine, or should you have any doubt about it, please contact our company's local sales agent.

Let's join our hands to create a better life!

Thank you

Contents

Chapter I Safety warnings	4
Chapter II Safety symbols	8
Chapter III Brief introduction of mini tiller	10
i. Major technical parameters	10
ii. Names of major parts and components of mini tiller	11
Chapter IV Operation method of the mini tiller	12
i. Assembly after unpacking	12
ii. Installation and adjustment of cables	12
iii. Check and oiling	14
iv. Starting	17
v. Operation	17
vi. Connection and operation of attached parts	18
vii. Precautions for use of mini tiller	19
Chapter V Maintenance of mini tiller	19
i. Running in	19
ii. Technical maintenance of mini tiller	20
iii. Technical maintenance schedule of mini tiller	21
iv. Long storage of mini tiller	22

Chapter VI Adjustment method of mini tiller	22
i. Method of adjusting reverse cable	22
ii. Method of adjusting clutch cable	22
iii. Method of adjusting throttle cable	23
iv. Method of using and adjusting handlebar	23
Chapter VII Trouble shooting of mini tiller	25
i. Trouble shooting of clutch	25
ii. Trouble shooting of transmission box	26
iii. Trouble shooting of running mechanism	28
iv. Trouble shooting for other parts	29

Chapter I Safety warnings

1. Training

a) Carefully read the operation manual. Get fully familiar with the correct method of operation of this machine and its mechanisms. Understand how to stop it and how to quickly disengage the operation mechanism.

b) No child is allowed to use the machine! No adult is allowed to use the machine before carefully reading the manual!

c) Ensure no other persons or things with potential safety risk, especially children and pets, are inside the working area!

2. Preparation

a) Thoroughly check the area for the machine to work in, and remove all sundries.

b) Before starting the engine, put shift gear in neutral position!

c) Don't operate the machine without the proper clothing. If the working area has a slippery ground, wear a pair of anti-skid shoes to improve your standing stability.

d) Take care when treating fuel, which is inflammable! Pay attention to the following rules:

1) Use an appropriate container to hold the fuel.

2) When the engine is running or is hot, never try to add fuel into it!

3) Take extra care when fueling the engine outdoors; never try to fuel the engine indoors!

- 4) Before starting, tighten the fuel tank cap and wipe off any fuel spilled out!
- e) Never try to make any adjustment when the engine is running!
- f) For any operation or work on the machine, for example, preparation and maintenance of the machine, wearing a pair of safety glasses is necessary.

3. Operation

- a) When starting the engine, the shift lever shall stay in the neutral position. The operator's hands and feet are not allowed to approach revolving parts or to be under such parts.
- b) When operating the machine on (or while crossing) a cobbled road, sidewalk, or highway, stay alert to the traffic conditions to notice any potential traffic risk! Never use the machine to carry any passenger!
- c) If the machine bumps against any foreign thing, please shut off the engine immediately, and thoroughly check whether the mini tiller is damaged, if so, repair it before restarting and operating it.
- d) Always pay attention to the surrounding conditions to avoid slipping down, or dropping.
- e) If the machine shows any abnormal vibration, shut off the engine without any delay! Check to find the reason, it's important because abnormal vibration normally is harbinger of fault.
- f) Before leaving the operating position to repair, adjust, check or remove of things jammed between blades, always remember to shut off the engine first!
- g) If the machine is to be left uncared by the operator, all necessary preventive measures,

such as disengaging power output shaft, lowering of accessory devices, shift to neutral position of gear shift lever, and shutting off the engine shall be taken first!

h) Before cleaning, repair or checking the machine, the operator must shut off the engine and ensure all moving parts are in a stationary state!

i) Engine's emission is hazardous, so never try to run it indoors!

j) Never operate the mini tiller without proper protection equipment, guard or other protection devices in place!

k) When the machine is running, always keep it away from children and pets!

l) Never overload the machine with a big tilling depth and a high speed!

m) The machine is not allowed to run at a high speed on a slippery road. Watch back to take care when driving backward!

n) Never allow any looker-on to approach a running machine!

o) Only the accessory devices and equipment (like the counter weight) allowed by the manufacturer of the mini tiller may be used

p) Never try to operate the mini tiller when the view is limited or lighting conditions are poor!

q) Take care when tilling a hard field, because the blades may hook into the ground, hence pushing the mini tiller forward. If such a result does occur, just let free the handle and don't try to control the machine!

r) Never operate the mini tiller on an abrupt slope!

s) Take care not to let the machine turn over when it is ascending or descending a slope!

4. Repair, maintenance and storage

a) Check at a fixed interval whether bolts under shear stress, mounting bolts of engine and other bolts are tightened properly, so as to ensure the machine can work safely.

b) The machine shall be stored indoors and away from flames, and please cool the engine before storing it.

c) If the mini tiller is to be stored for a long time, the manual shall always be kept as an important material.

d) Don't repair the machine at will unless you have the proper tools and the manual to instruct disassembling, assembling and repairing of the machine.

Chapter II Safety symbols

The following symbols are to remind you that if you don't pay attention, you might be severely injured. Please carefully read the symbols and notices about safety in the manual.

If these symbols peel off or are illegible, please contact the distributor to replace such symbols.

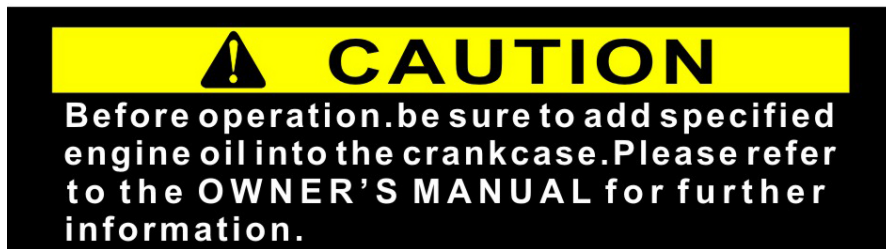

Figure 2-1

Figure 2-1 to be stuck on engine fuel tank

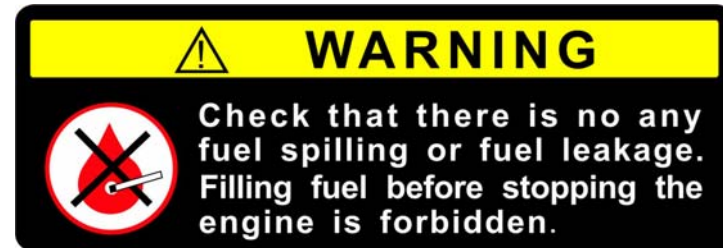

Figure 2-2

Figure 2-2 to be stuck on engine fuel tank

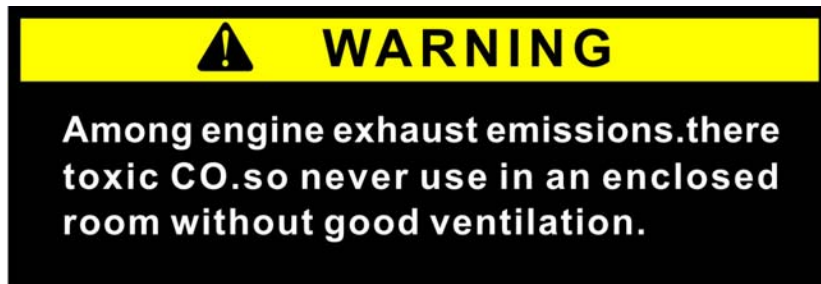

Figure 2-3

Figure 2-3 to be stuck on engine fuel tank

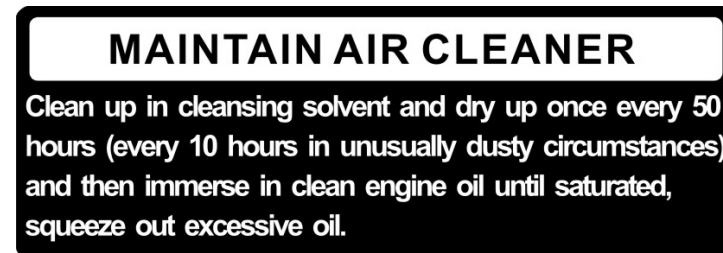

Figure 2-4

Figure 2-4 to be stuck on engine air filter

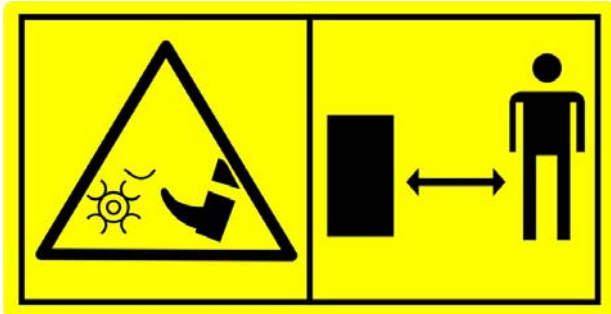

Figure 2-5
Figure 2-5 to be stuck on fender



Figure 2-6
Figure 2-6 to be stuck on fender

All the safety symbols conform to GB10396.

Chapter III Brief introduction of mini tiller

This product is made in compliance with JB/T10266.1-2001 Specification of Handheld Tillers, JB/T10266.2-2001 Testing Method for Handheld Tillers, GB/T5608.3-1995 Testing Method of Rotary Tillers, GB10395.10-2006 Tractors and Machinery for Agriculture and Forestry—Technical Means for Ensuring Safety and DB50/210-2005 Technical Means for Ensuring Safe Operation of Handheld Tillers.

i. Major technical parameters

Item name		Parameters
Corresponding power		168F-2
Maximum theoretical power kW (r/min)		4.8/3600
Weight (without rotary tilling device) (kg)		60
External size (L×W×H) (mm)		1250×850×1000
Productivity/hour	hm ² /h.m	≥0.04
Productivity	Rotary tilling (m ² /h)	≥400
Tilling depth	Rotary tilling (mm)	≥100
Tilling width	Rotary tilling (mm)	800~1000
Working speed	Forward (m/s)	1.6/2
	Backward (m/s)	1.2
Tilling blade rotation radius (mm)		150~190

ii. Names of major parts and components of mini tiller

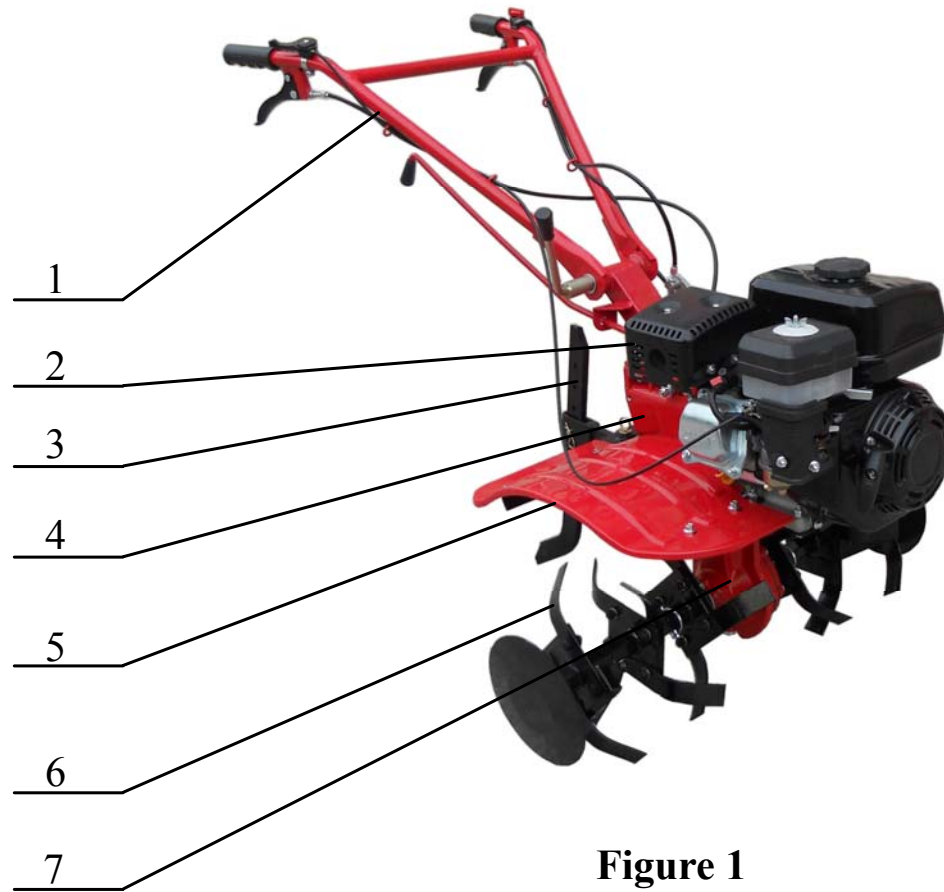

Figure 1

- | | | | |
|-----------------------|---------------------------|--------------------------------|------------------------------|
| 1. Handlebar assembly | 2. Engine assembly | 3. Drag bar | 4. Transmission box assembly |
| 5. Fender | 6. Tilling blade assembly | 7. Reduction gear box assembly | |

Chapter IV Operation method of the mini tiller

i. Assembly after unpacking

1. Installation of wheel: install the wheels onto both ends of output shaft and use 2 locking pin assemblies to secure them.

2. Installation of drag bar: fix the drag bar connector onto the hitch box, use a hitch pin to connect them, and insert a $\Phi 3.5 \times \Phi 13 \times 81$ clip; then insert the drag bar into the square hole of the connector and use a $\Phi 8 \times 43$ pin and a $\Phi 2.5 \times \Phi 9 \times 46$ clip to secure them.

3. Installation of handlebar assembly: align the tooth disc on the handlebar to the tooth disc on the handlebar seat, take care to adjust the vertical position of the handlebar, and use the adjusting handle and a $M16 \times 140$ bolt to connect handlebar assembly onto the handlebar seat and tighten it.

4. Installation of shift lever: insert the shift lever through the hole of the handlebar seat's lug, and into the hole of the gear shift arm, and then use a $\Phi 2.5 \times \Phi 9 \times 46$ clip to secure it. Put the shift lever in the neutral position.

5. Refer to the illustrations of the mini tiller's accessories for information about assembling of the mini tiller.

ii. Installation and adjustment of cables

1. Adjustment of clutch cable (see Figure 2 and Figure 4).

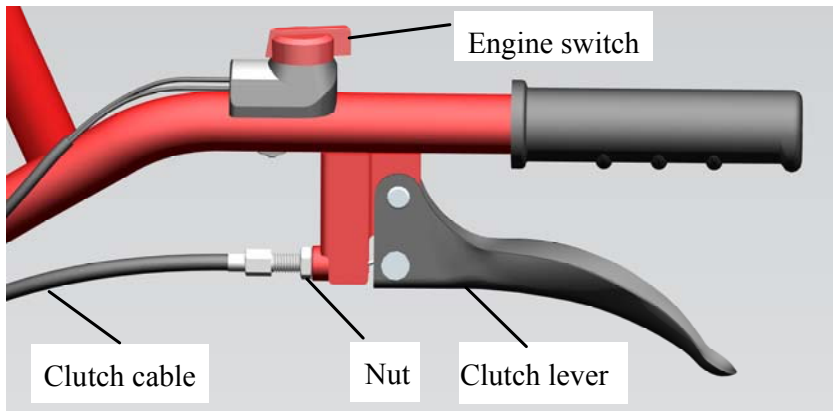

Figure 2

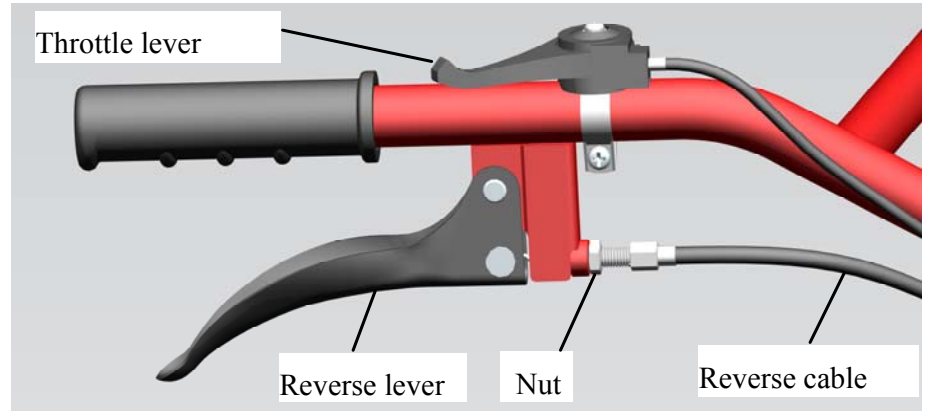

Figure 3

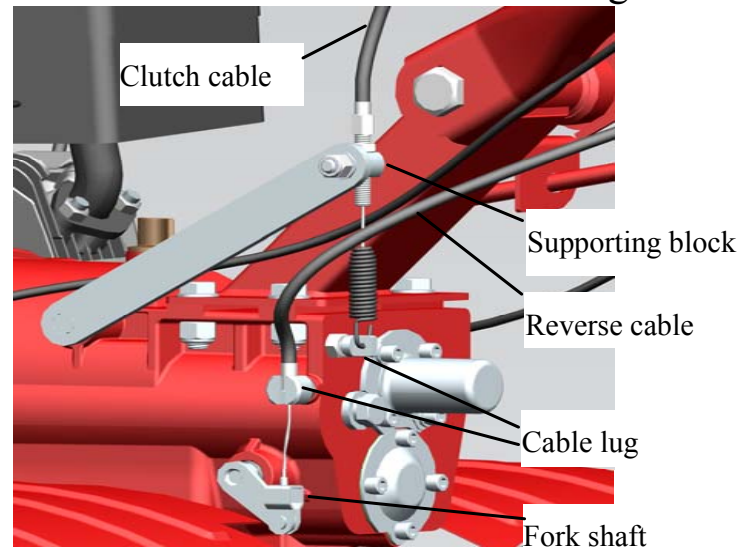

Figure 4

2. Adjustment of reverse cable (see Figure 3 and Figure 4)

1) Loosen the nut around the reverse cable.

2) Turn clockwise the screw until its exposed part from the handle pipe is of its shortest length.

- 3) Insert the reverse cable into the fork shaft on one side of the transmission box and make sure the front end of the reverse cable is in the big hole of the fork shaft.
- 4) Turn counterclockwise the reverse shift fork shaft appropriately and insert the cable through the opening of the cable lug on one side of the transmission box, make sure the front end of conduit is in the big hole of the cable lug.
- 5) Loosen out the screw and grip it firmly several times, then release the reverse shift handle, when the spring tension can return the position of the reverse shift handle, tighten the nut.

3. Adjustment of throttle cable

- 1) Turn the throttle lever in an anticlockwise direction to the “L” position.
- 2) Insert the steel wire rope of the throttle cable through the hold-down plate and fixing hole on the upper side of the accelerator regulator board.
- 3) Tension the steel wire rope and tighten the fixing bolt of the fixing seat.
- 4) Repeat adjustment of the throttle switch until the accelerator valve regulator lever’s handle can move to the “minimum” and “maximum” positions.

iii. Check and oiling

1. Check whether any bolt connection is loose, and if there is any loose connection, tighten it as per the requirement of bolt connection torques listed in the next table . For information of tightening torques of engine’s bolts and nuts, please refer to manual of engine.

Name	Toque (N.m)
Flange of transmission box and engine	20~25
Transmission box and flange of transmission box	25~30
Bolt to secure back end of transmission box’s drive shaft	10~12
Bolt to secure transmission box’s reverse shaft	26~40

Bolt to secure engine bracket and transmission box	35~40
Bolt to secure reduction box cover	25~30
Bolt to secure damping lever fixing seat	50~60
Bolt to connect transmission box and reduction box	25~30
Bolt to secure engine bracket and engine	25~30

2. Check whether handles of operating system, namely the handles for accelerator, clutch, gear shift, and reverse shift can work freely, and whether any of them cannot reach any required position, if so, check to repair it.

3. Put the shift lever of the transmission box in the neutral position.

4. Filling of engine oil.

Put the engine on a horizontal place.

1) Loosen out the dip stick of the engine, and wipe it off (see Figure 5).

2) Put the dip stick into the oil filler hole (don't engage the thread)

3) Take out the dip stick to check oil level; if the oil trace is between the upper and lower marks of the oil stick, the oil level is acceptable.

4) The SAE15W-40 engine oil is the recommended general-purpose lubricant, and it is applicable to a common ambient temperature (see Table 1).

5) Put the whole machine in a horizontal position. Take off the oil plug and add in about 2 liter of SAE15W-40 engine oil to the transmission box. The normal oil level shall be at the middle of the oil window (see Figure 6).

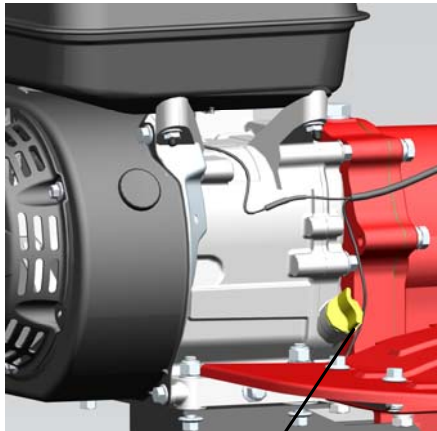

Dip stick

Figure 5

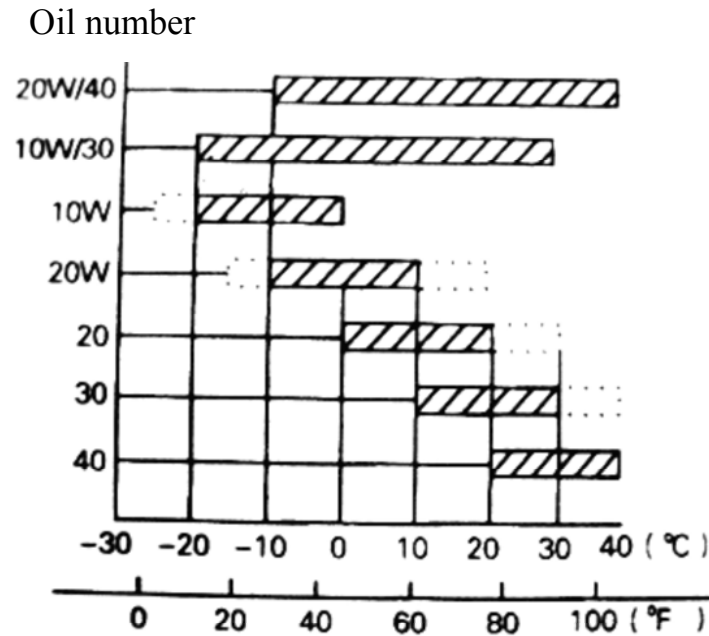

▨ Recommended numbers ⋯ Extreme usable numbers

Table 1

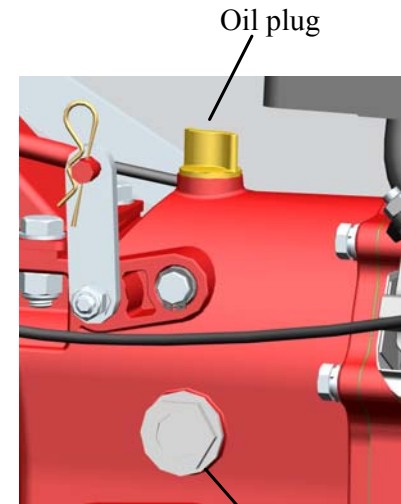

Oil window

Figure 6

- 6) Fill air filter with engine oil. Detach the lower cover of air filter and add in about 0.1 liter of SAE15W-40 engine oil.
- 7) Select the number of engine oil according to the ambient temperature of the working environment (see Table 1).

5. Add fuel into engine. No.93 or No.97 gasoline can be added into the fuel tank of engine (refer to engine manual for details).

Note: never let oil level be higher than the upper limit.

6. Prepare the engine as required by engine manual before starting it.

iv. Starting

Note: shift lever must be in the neutral position.

1. Start the engine by following the steps specified in the engine manual.
2. Run the engine at the idle speed (1800 ± 150 r / min) without load for 2 to 3 minutes.
3. Check whether the engine runs normally, if not, stop it to repair.

v. Operation

Note: the mini tiller must be run in before being operated. See Chapter IV for method of running in.

1. Shift to “slow” position.
 - 1) Left hand releases the clutch handle to let clutch disengage.
 - 2) Right hand pulls back the shift lever to “slow” position, take care to ensure it does reach “slow” position, then right hand grips the right handrail (note: don’t grip the reverse shift handle).
 - 3) Slowly tighten your grip on clutch handle to engage the clutch, then the mini tiller can run at a low speed.
 - 4) Right hand opens accelerator valve wider appropriately, then the mini tiller will run at a low speed, namely about 5km/h.
2. Shift to “fast” position
 - 1) Left hand releases the clutch handle to let clutch disengage.
 - 2) Right hand pushes up the shift lever to “fast” position, take care to ensure it does reach “fast” position, then right hand grips the right handrail (note: don’t grip the reverse shift handle).
 - 3) Slowly tighten your grip on clutch handle to engage the clutch, then the mini tiller can run at a fast speed.

Right hand opens accelerator valve wider appropriately, then the mini tiller will run at a fast speed, namely

about 8km/h.

3. Shift to “reverse” position

- 1) Left hand releases the clutch handle to let clutch disengage.
- 2) Right hand puts the shift lever to “neutral” position, take care to ensure it does reach “neutral” position, then slowly tighten your grip on the reverse shift handle.
- 3) Slowly tighten your grip on clutch handle to let the clutch engage, then mini tiller will run backward (note: don’t release the reverse shift handle).
- 4) When you don’t need to run backward, just let your left hand release the clutch handle, and let your right hand release reverse shift handle.

4. If you want to shift gear during running, reduce accelerator valve opening first but don’t let engine stall, then disengage the clutch, and shift gear when the mini tiller has stopped running.

5. If you want to change running direction of the mini tiller, just push the handrails leftward or rightward.

Note: don’t grip the handle when changing running direction, or the gear might be damaged.

6. Stopping

- 1) Release the clutch handle to keep the clutch disengaged.
- 2) Put the shift lever in the neutral position, push the accelerator valve regulator lever clockwise to the “minimum” position, and put the start switch on OFF position, then the mini tiller will stop running.
- 3) When you want to stop the engine, follow the relevant information in the engine’s manual (note: normally the mini tiller can be stopped on a level ground).

vi. Connection and operation of attached parts

1. When you want to start rotary tilling, detach the wheel and put the hexagon bush of the rotary tilling device over the two ends of the output shaft of the running mechanism. Note: rotary tilling blades are arranged into left blade set and right blade set; installation of them shall ensure that when the mini tiller is running forward, the edges of the blades work first. After installing the rotary tilling blades, you must install the fender to prevent personal injury by the blades. Depth of rotary tilling can be adjusted by adjusting height of the damping lever.

2. Tilling in the irrigated field: when the length of “muddy foot” (i.e. the depth of the operator’s subsidence into mud) is shorter than 25 cm, the wet soil rotary blade set can be used to till the field. If the length of muddy foot is between 25 and 45 cm, the operator can use irrigated field rotary tilling roller to till the field.

vii. Precautions for use of mini tiller

1. Observe the working status of different parts and carefully listen to the machine’s sound, check to see if connections of different parts are normal, because loose connection is not allowed. If any abnormal condition is found, the operator should stop and check.

2. It is not allowed to work with heavy load right after cold start, especially when the machine is a new one or an overhauled one.

3. Check the oil levels of engine and transmission box, if the oil levels in them are too low, replenish them with engine oil.

4. Never try to cool the engine by pouring water on it.

5. When tilling, take care to prevent the mini tiller from falling over.

6. Never run a mini tiller equipped with rotary tilling blades on a beach or on a surface covered with pebbles, or the blades will be damaged.

7. After using the mini tiller, make sure to remove the mud, weeds or oily grime on the mini tiller to keep the whole machine clean.

8. Often clean the spongy element or steel mesh inside the filter and change its engine oil.

Chapter V Maintenance of mini tiller

Due to wear from running, friction and change of load, the mini tiller’s bolts may get loose, and parts and components may get worn, causing lower power of the gasoline engine, higher fuel consumption rate and other faults that will affect use of the mini tiller. In order to keep the above adverse conditions to a minimum level, it is necessary to strictly and regularly conduct maintenance of the mini tiller, so that it can maintain a good technical condition and have a longer service life.

i. Running in

1. Please refer to the manual for information about running-in of the gasoline engine.
2. A new or overhauled mini tiller shall work for one hour without load first, then work for another five hours under a light load, and when the engine is still warm, drain all engine oil in the crankcase of the engine. Fill the engine with engine oil and run it for 4 hours for running in, then the machine can be used for normal farming.

ii Technical maintenance of mini tiller

1. Maintenance per shift (before and after each shift of work)

- ① Listen and watch to check if there is any abnormal phenomenon like abnormal noise, overheating, loose bolts, etc.
- ② Check if there is any oil leakage from the engine and transmission box.
- ③ Check if oil levels of the engine and transmission box are between the upper and lower marks of their oil level indicators.
- ④ Timely remove dirt, grime, weeds and oil stains on the whole machine and its accessories.
- ⑤ Keep the farming record.

2. First-level maintenance (every 150 hours of work)

- ① Conduct all items of maintenance for each shift.
- ② Clean transmission box, and change engine oil.
- ③ Check, test and adjust clutch, gear shift system and reverse gear system.

3. Second-level maintenance (every 800 hours of work)

- ① Conduct all items of the maintenance for every 150 hours of work.
- ② Check all gears and bearings, if any of them is severely worn, replace it.
- ③ If any of the mini tiller's other parts and components, such as any tilling blade or bolt, is damaged, please replace it.

4. Technical check and repair (every 1,500-2,000 hours of work)

- ① Disassemble the whole machine at a local authorized service shop to clean and check it, and if any of the parts and components is severely worn, replace it or repair it if it is appropriate to do so.
 - ② Ask repair and maintenance professionals to check friction disks and clutch.
5. Repair and maintenance of engine shall be conducted as per the engine’s manual.

iii. Technical maintenance schedule of mini tiller (an item marked with ● shall be maintained)

Work Time / Content of maintenance	Every day	After 8 hours of work under a half load	After the first month or after 20 hours	After the third month or after 150 hours	Every year or 1,000 hours	Every 2 years or 2,000 hours
Check and tighten bolts and nuts	●					
Check and add new engine oil	●					
Clean and change engine oil		● (First time)	● (Second time)	● (Third time and thereafter)		
Check if there’s oil leakage	●					
Clean dirt, weeds, and oil stains	●					
Solve problems	●					
Adjust operating parts	●					
Friction disk						●
Gears and bearings					●	

iv. Long storage of mini-tiller

If the mini tiller need be stored for a long time, the following measures should be taken to prevent rust and erosion.

1. Seal up and store the engine as per requirements in the manual of engine.
2. Clean dirt and grime on the outer surface,
3. Drain lubricant from the transmission box and fill it with new lubricant.
4. Apply anti-corrosion oil on unpainted part of the non-aluminum-alloy surface.
5. Keep the product in a well ventilated, dry and safe indoor place.
6. Properly keep the tools, quality certificate and operation manual attached to the machine.

Chapter VI Adjustment method of mini tiller

i Method of adjusting reverse cable

When it is confirmed that the mini tiller's reverse running is abnormal, the reverse shift handle and reverse cable shall be adjusted right away, please refer to Chapter III for method of adjustment.

Note:

1. Grip firmly and release the reverse shift handle 2 to 3 times to confirm the working performance of gear shifting operation, if it is abnormal, readjust the reverse shift handle and reverse cable until the gear shifting operation is normal.

2. During running of the mini tiller, if you release the reverse shift handle, the reverse gear should be able to return right away, and no abnormal of gear clashing should be heard from inside transmission box, if so, the gears will be damaged.

ii. Method of adjusting clutch cable

When the mini tiller has been used for a period and its performance has worsen due to wear of friction disks and clutch forks, the clutch cable should be adjusted; please refer to Chapter III for method of adjustment.

Note:

1. Grip firmly and release the clutch handle 2 to 3 times to confirm the working performance of the clutch. If it is abnormal, readjust the clutch.

2. If the clutch's work is still abnormal after several times of adjustment, it can be confirmed that the wear of clutch forks or friction disks is too heavy, and the mini tiller's friction disks or clutch forks shall be replaced with new ones by an authorized service shop.

3. Never try to detach the clutch by yourself, or the clutch or other parts or components may be damaged.

iii. Method of adjusting throttle cable

If the engine's accelerating or decelerating performance is not good when you turn the throttle lever, please adjust the throttle cable right away; you can refer to Chapter III for method of adjustment.

Note:

Turn the throttle lever 2 to 3 times to confirm the engine's accelerating and decelerating performance.

iv. Method of using and adjusting handlebar

According to your height and the special requirements of your farming, the handlebar can be adjusted appropriately in two directions: up, down.

Method of adjustment (see Figure 7):

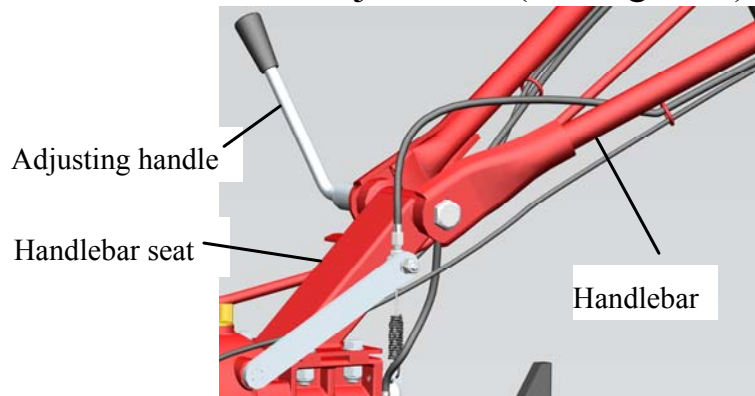

Figure 7

- 1) Loosen the Adjusting handle.
- 2) Reposition the handlebar according to your height and habit.
- 3) Make sure the teeth of the handlebar and the teeth of the handlebar seat are engaged.
- 4) Tighten the Adjusting handle.

Chapter VII Troubleshooting of mini tiller

i. Troubleshooting of clutch (note: never try to detach the clutch assembly by your self, if you find any of the malfunctions marked with ※ in the table below, please contact our company or the distributor)

Phenomenon	Cause	Solution
Clutch unable to engage and disengage	Clutch handle fails	Replace or repair clutch handle
	Clutch cable is damaged	Replace clutch cable
	Clutch fork is not adjusted adequately	Readjust clutch cable or replace clutch fork
	Fork shaft falls off from its welding junction with arm seat	Replace or repair
	Fork pin is broken or bent	Replace fork pin
	※Friction disk fails	Replace friction disk
	※Spring fails	Replace spring
	Friction disk set can't contact bearing face inside the clutch housing	Insert one washer or more of appropriate thickness behind the bearing
	Bearing inside clutch is burnt out	Replace bearing and if necessary, add oil into transmission box
Skidding (when the operator firmly grips clutch handle, engine runs normally but transmission main shaft rotates slowly or doesn't rotate.	※Spring fails because of fatigue	Replace spring
	Fork shaft's rotation is abnormal, or it fails, causing uncompleted return of fork	Clean the junction surface between locating shaft and pusher, to let rotation of fork shaft be easy
	Clutch cable is adjusted inappropriately	Readjust clutch cable

ii. Trouble shooting of transmission box

Phenomenon	Cause	Solution
Gear engagement in fast, slow and neutral positions are not reliable	Back-end bolt of main shaft is loose and the round nut is loose	Detach the main shaft's back-end bolt, protecting bush, retighten the round nut and then refit the protecting bush and bolt, and retighten them
Uncompleted gear engagement	Block's wear is too heavy	Replace block
	Driving bevel gear is loose	Tighten round nut
	Wear of upper hole of shift block is too heavy	Replace shift cam and shift block
	Positioning spring inside main shaft fails	Replace spring
	Main shaft bounces forward and backward due to loosening of gland bolt of the rear part of transmission box,	Retighten gland bolt
	Interference during gear shifting caused by deformation of shift lever	Straighten shift lever or replace it
Uncompleted gear reversing	Wear of fork	Readjust reverse cable or replace fork
	Reverse cable fails	Readjust cable or replace it
	Reverse shaft is loose	Tighten back-end bolt of reverse shaft
	Fork shaft is seized	Clean the junction face of fork shaft and pusher to let fork shaft be able to rotate easily
Uncompleted movement of reverse gear	Reverse shaft is loose, which causes seizure of gear	Retighten back-end bolt of reverse shaft
	Spring of reverse shaft fails	Replace spring

	Deformation of reverse shaft	Replace reverse shaft
Reverse shaft is loose	Back-end bolt of reverse shaft is loose	Retighten back-end bolt of reverse shaft
	Fit between reverse shaft and transmission box is too loose	Replace
Too high noise from gear	Countershaft or reverse shaft is deformed or bent	Replace bent shaft
	Gear wear is too heavy, which makes lateral clearance out of tolerance	Replace gear
	Fit between countershaft or reverse shaft and transmission box is too loose	Replace
Oil leak from back cover of main shaft	O-ring of main shaft fails	Replace $\Phi 13 \times 1.9$ O ring
	Oil seal of main shaft fails	Replace $20 \times 35 \times 7$ oil seal
	Oil seal seat's O-ring fails	Replace $\Phi 38 \times 1.8$ O ring
Oil leak from reverse shaft	Back-end bolt of reverse shaft is loose	Retighten the bolt
	Reverse shaft's O ring fails	Replace $\Phi 18 \times 1.8$ O ring
Oil leak from fork shaft	O ring fails	Replace $\Phi 10 \times 2.0$ O ring
Oil leak from clutch-operating lever assembly	O ring fails	Replace $\Phi 10 \times 2.0$ O ring
Oil leak from shift cam	O ring fails	Replace $\Phi 10 \times 2.0$ O ring
Oil leak from conjunction of flange	Bolt here is loose	Retighten bolt
	Paper gasket here is damaged	Replace damaged gasket
Oil leak from transmission box wall	Pinholes hidden in the transmission box wall	Repair by welding or applying base coat

iii. Trouble shooting of running mechanism

Phenomenon	Cause	Solution
Too high noise from gear	Too heavy wear or incorrect repair of gear	Reinstall, adjust or replace gear
Seizure of gear during its rotation	Incorrect installation	Reinstall it
Overheating	Lubricant inside box is too insufficient	Add engine oil as required
	Lateral clearance of gear is too small	Reinstall gear
	Axial internal clearance is too small	Reinstall gear
Oil leak from connections of transmission box	Connecting bolt is loose	Retighten bolt
	Seal gasket is damaged	Replace seal gasket
Oil leak from outer cylindrical surface of output shaft	Oil seal here is damaged	Replace 25×47×7 oil seal
Severe oil leak from transmission countershaft's hexagon hole	The countershaft is broken	Replace countershaft
Oil leak from oil drain hole	Seal gasket is damaged	Replace $\Phi 10 \times 2.65$ O ring
	Threaded plug is loose	Retighten threaded plug as required
Oil leak from transmission box wall	Hidden pinholes in the transmission box wall	Repair by welding or applying base coat

iv. Trouble shooting for other parts

Phenomenon	Cause	Solution
Rotary tilling blade is broken	Blade hits stones, bricks or other hard objects during working	Replace broken blade and take care to avoid blade's clashing with stones or other hard objects in soil
Operating cable is broken	Wear caused by long work	Replace operating cable



隆鑫通用动力股份有限公司
Loncin motor co., Ltd.

详细地址：重庆市九龙坡区九龙工业园区华龙大道99号

服务电话：023 8980 5678/8980 8505

传 真：023-8906 7566

邮政编码：400052

Email: marketing@loncinengine.com

Website: www.loncinengine.com

PRINTED IN CHINA