



General Power Products

Welding & Generator Set

WG6500M-1

WG6500MT-1

WG6500MP-1

Owner's Manual



Thank you for purchasing a welding/generating set produced by Loncin Company.

Please keep this Manual in a reliable way for you convenient reference at any time.



This Manual should be considered a permanent part of the generator and should remain with it if it is resold.

Loncin adheres to a strategy of sustainable development, so Loncin reserves the right to make changes or improvements without notice to any product described in this publication.

Copyright © Loncin Motor Co., Ltd. All rights reserved.

No part of this publication may be reproduced, transmitted, distributed or stored without prior written permission of Loncin Motor Co., Ltd.

Safety Warnings

Personal and property safety of you and other persons are of great concern to us. Please carefully read the each safety warning preceded by the symbol  and each safety indication preceded by the symbol of , details of which are as follows:

 **DANGER** You WILL BE VERY SERIOUSLY HURT if you don't follow instructions.

 **WARNING** You CAN BE SERIOUSLY HURT if you don't follow instructions.

 **CAUTION** You CAN BE HURT if you don't follow instructions.

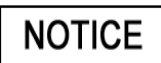
 **NOTICE** Your generator or other property could be damaged if you don't follow instructions.

Contents

Contents

I. Safety	2
II. Brief introduction of functions	6
III. Description of the set's parts and components and their functions	7
Engine switch	8
Fuel switch	8
Choke switch	8
Recoil starter	9
AC circuit breaker	9
IV. Preoperation check	11
Routine check	11
Oil check	11
Fuel check	11
Air filter check	12
V. Operation and use of the set	13
Starting the engine	13
Use of the generator	13
Use of welding power supply	15
Stopping the engine	16
VI. Maintenance of the set	17
Engine Oil change	18
Air filter maintenance	18
Cleaning fuel sediment cup	19
Spark plug check	20
VII. Storage	21
VIII. Troubleshooting	22
Engine doesn't start	22
No output voltage	22
Solving common problems of welding power supply	23
IX. Technical parameters	24
X. Schematic diagram	25
XI. Wheel and handle Set(In Optional)	26

I. Safety

Please carefully read and understand this Manual before operating the engine; safe operation procedures can help you avoid personal injury or damage to the set.

1) General descriptions



This type of welding/generating set is produced in accordance with technical regulations governing generators and welding machines, and it conforms to all relevant safety regulations; but misoperation or misuse still can result in the following hazards:

- The set's hazard to the life safety of the operator and any other person,
- Damage to the public or private property,
- Adverse influence on the effective work of the equipment.

2) Duty of the owner/keeper

- Be familiar with basic work safety rules and operation method of welding machines.
- Read safety rules and warnings of the Manual and be clear about relevant signals.
- Be able to conduct routine check to ensure operator's safety during work.

3) Duty of the operator

- Obey basic work safety rules, understand basic knowledge of generators and welding machines, and have relevant qualifications and certificates.
- Read the part contained in the Manual's safety warning section, and operate in accordance with the Manual's instructions.
- Sign to indicate understanding of the above.

Never use it indoors



4) Safety operation and protection

- Insulation measures, such as wearing insulation shoes, must be taken for operation in a wet condition.
- Wear insulation gloves before welding.
- Wearing a welding mask to protect eyes from being hurt by ultraviolet radiation.

Never use it in a wet condition



Never connect it directly to the home power supply



- Wear a protective working suit.
- Wear a pair of noise protectors in any place with a loud noise.

If there is any other person nearby during welding, you must

- Inform him or her of the danger,
- Use protective equipment or other means to protect such person,
- Erect a separator or hang a screen.

5) Eliminating poisonous gases and fumes

- Take measures to eliminate all fumes and poisonous gases in the working room.
- Ensure air ventilation.
- Take measures to separate arc radiation.
- Prevent hazards from weld spatter
- Remove all inflammable matters from the welding site.
- Never weld the containers with residual inflammable gases, fuel or oil, or an explosion may be caused.
- A safety place must be assigned for hazardous emergencies.

Keep inflammable materials at least 1 meter away

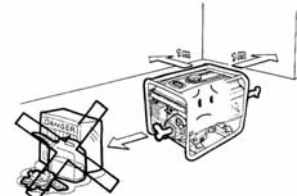

Never smoke when fueling



Never spill when fueling



Stop engine before fueling



6) Prevent electric shock from network voltage and welding voltage

- Electric shock can cause extremely dangerous effect, including to life safety.
- A strong current will create a magnetic field, which can disturb functions of important electronic devices like the cardiac pacemakers.
- Any person equipped with a cardiac pacemaker must check if there is any magnetic field beside or in the working room before entering it.
- Ensure all earth wires are reliably connected without any da

and are entirely insulated. If there is any loose connection, loss of insulation, or burned section in any earth wire, replace such earth wire immediately.

- Main power lines and branch lines must be regularly inspected by a qualified and experienced electrician to ensure semiconductor parts work normally.
- Before dismantling the set to take any part down, make sure the set is reliably shut off.
- If any such work must be done while the set is running, a second person must be available on the site to guarantee the ability to perform an emergency stopping of the set.

7) Cautions

- Never put your hands near any of the revolving gears of the wire feeder.
- For any operation with the probability of spark, explosion or other dangers, a separate welding place has to be applied for.
- The welding power supply may not be used for high-voltage application unless it has passed relevant safety certification.
- Welding of special safety equipment must be performed by welders that have received professional training.
- When any equipment is going to be lifted using a lifting machine, for the purpose of lifting as perpendicularly as possible, generally chains or ropes can be used to help lifting.

8) General safety measures

- Always following the instructions of this Manual.
- In addition to the Manual, two copies respectively of rules for general accident prevention and for environment protection shall be prepared. Of course, any other applicable regulation also has to be observed.
- All safety instructions and hazard warnings must be kept clear and legible enough.

9) Safety measures for installing the set

- The set must be put upright on a level ground to prevent its falling and personal injury.
- For any work that might involve spark, explosion or other hazardous factors, a

separate welding space must be applied for. Please refer to relevant regulations of China and other countries.

- Use internal inspection and test means to ensure the working environment is clean and orderly.

10) Safety measures to guarantee normal work of welding/generating set

- Before running the set, check whether all safety protection requirements are met.
- Don't touch any hot part of the set within 30 minutes after the set is shut down, so as to ensure no personal injury will occur when you start the workstation.
- Inspect the set at least once a week, conduct a check of the set's external surface for any damage, and test its safety performance.

11) Safety inspection and test

- All operations about the set's modification, installation of accessories, maintenance and repair of parts and components, regular maintenance, overall inspection and test (which must be performed once for every period not exceeding 6 months), etc. shall be assigned by the owner/ keeper of the set to electric experts.

12) Modification of welding/generating set

- It is better not to make any modification to the set, to install any accessory to it, or to change any preset parameter of it without the manufacturer's permission.
- Defective parts or components must be replaced timely.

13) Spare parts and wearing parts

- Only the spare parts and wearing parts supplied by the manufacturer of the set may be used, because it cannot be ensured that the parts from other suppliers can meet the special design requirements and other requirements relating to voltage endurance and safety of this set.
- Before purchasing spare parts, please mark the specific names of the parts and relevant part numbers, and give relevant descriptions in the list of the spare parts.

II. Brief introduction of functions

WG6500-1 is a series of integrated welding/generating set.

- The set employs a 50Hz/230VAC generating set with a rated output of 5kW and maximum output of 5.5 kW, and guarantees a stable and adequate output voltage.
- The engine's fuel consumption rate is $\leq 370\text{g/kW.h}$; it is equipped with a 25L large fuel tank to meet the need of long-time operation.
- Manual welding, DC argon-arc welding and pulse argon-arc welding are available.
- Maximum welding current values of manual welding, DC argon-arc welding and pulse argon-arc welding are respectively 150A, 200A, and 200A (pulse frequency is 30Hz), the current can be adjusted in a continuous way from the minimum value of 15 A to the maximum values; current values are shown in a digital display, and observation of them is very easy
- High-frequency arc starting is employed by the argon-arc welding to achieve an easy arc starting.
- The total power of the equipment can be used for welding, or 5 kW of it can be all used for supply to the 50Hz/230VAC power network; in addition, the residual power during welding can also be used for supply to the external power grid.
- The welding unit of the set has self-protection functions against over current, under voltage, and over heating, so that safe work of the equipment is guaranteed.

III. Description of the set's parts and components and their functions

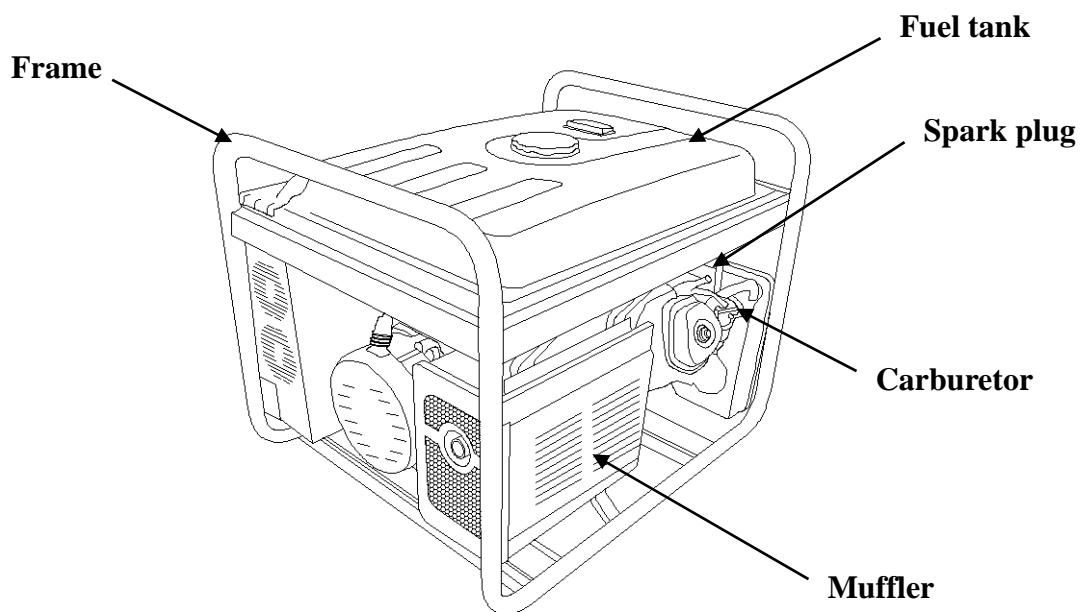
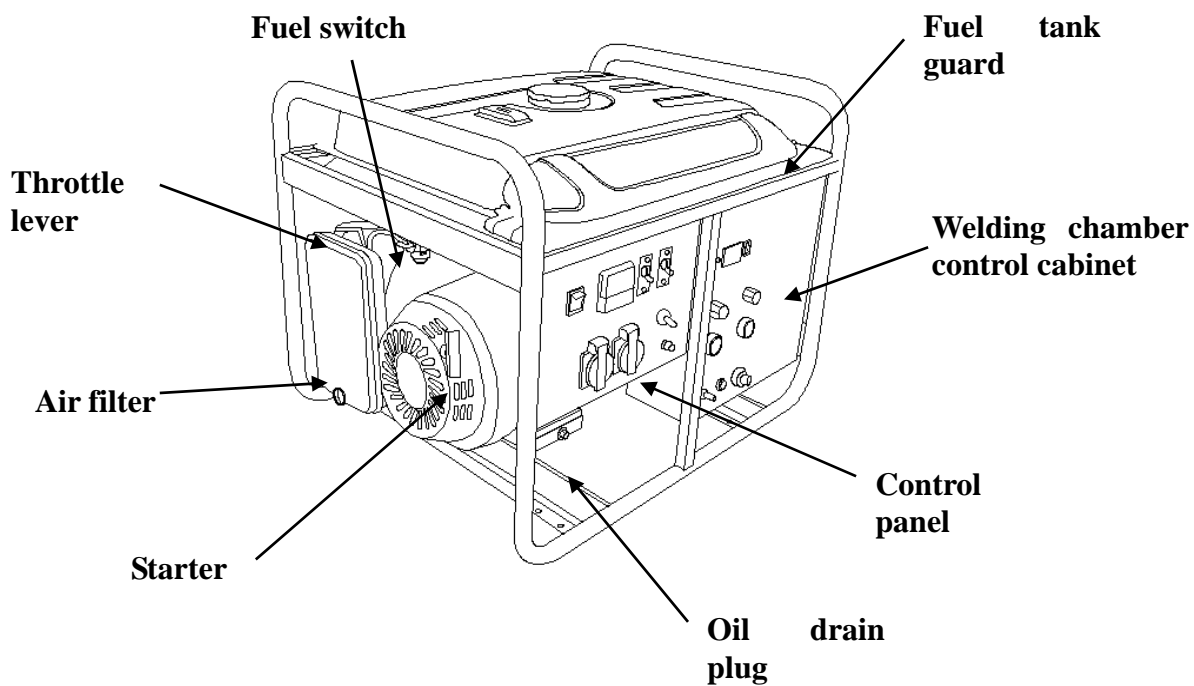

1) Engine switch

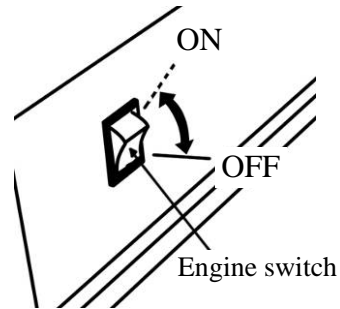

2) Fuel switch

The fuel switch is for opening and closing the passage of fuel flow from the fuel tank to the carburetor.

If the fuel switch is not put in the ON position, the engine cannot run. When the engine is not to be used, the fuel switch must be put in the OFF position to prevent fuel leak.

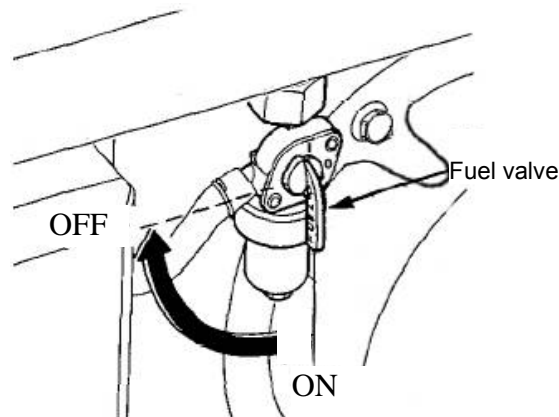

3) Choke switch

The choke switch is for opening and closing the choke inside the carburetor.

If the engine should have a cold start, put the choke lever in the OFF position. When the engine is running normally after starting, the choke lever shall be put in the ON position.

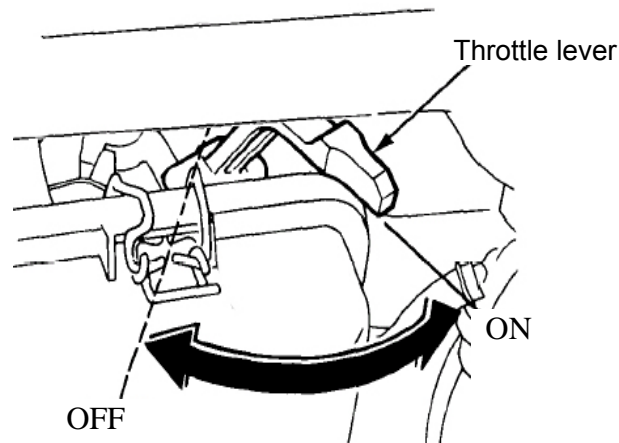

4) Recoil starter

Pulling the recoil starter grip enables the recoil starter to drive the engine's crank shaft, which in turn starts the engine.

NOTICE Don't let the starter grip spring back abruptly after starting; the starter grip should be let back gently.

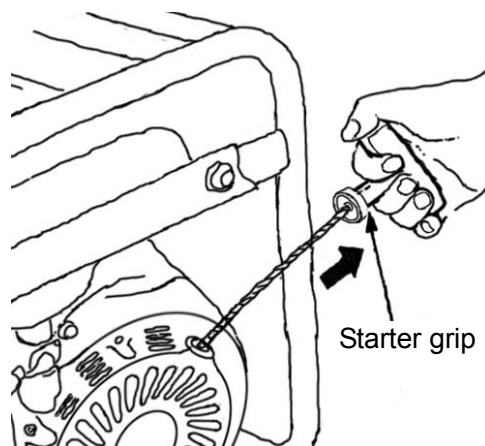

5) AC circuit breaker

The AC circuit breaker will be automatically shut off in the event of overload current. Overload and short-circuiting of the loads shall be avoided. If the circuit breaker is automatically shut off, please check the load before repositioning the circuit breaker in the ON position.

Description of the set's parts and components and their functions

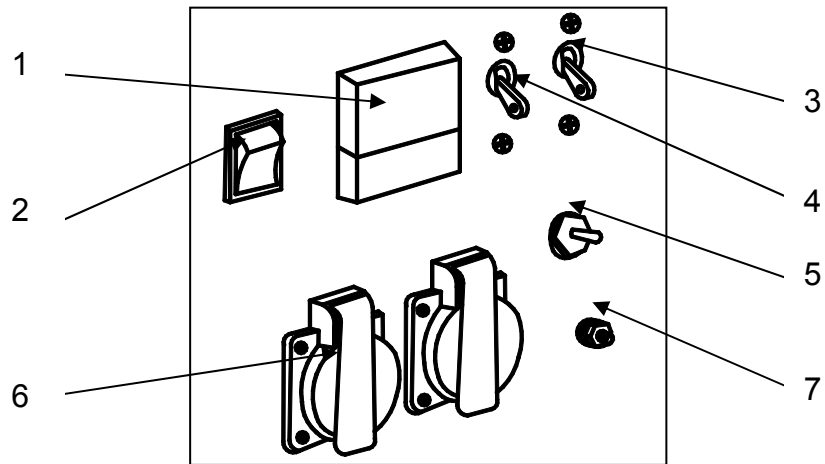

1—AC voltage meter 2—Engine switch 3—Main circuit breaker 4—Generator circuit breaker
5—Welding switch 6—Receptacle 7—Earthing terminal

IV. Preoperation check

1) Routine check

- Observe whether there is any leak of engine oil or fuel.
- Observe whether there is any trace of damage.
- Check the positions of all guards and covers, and tightness of all bolts, nuts and screws.

2) Oil check

NOTICE

Stop the engine and put it on a level place, then check engine oil.

- ① Remove the oil dipstick from the oil filler hole and wipe it clean;
- ② Insert the dipstick without screwing it in tight to check the engine oil level;
- ③ If the engine oil level is too low, add recommended engine oil until oil level reaches the upper limit;
- ④ After adding oil, remember to rescrew in and tighten the oil dipstick.

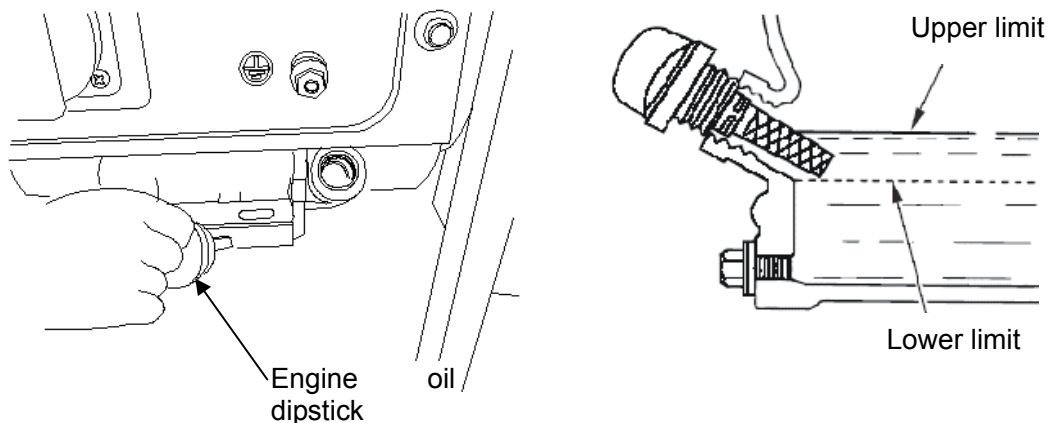

The Oil Alert system (applicable engine types) will automatically stop the engine before the oil level falls below safe limits. However, to avoid the inconvenience of an unexpected shutdown, always check the engine oil level before starting.

3) Fuel check

With the engine stopped, remove the fuel tank cap and check the fuel level. Refill the tank if the fuel level is too low. After adding fuel, reinstall and tighten fuel tank cap.

NOTICE

During adding fuel, take care not to let fuel level rise above the fuel shoulder (the maximum fuel level)

Fuel tank capacity: 25L

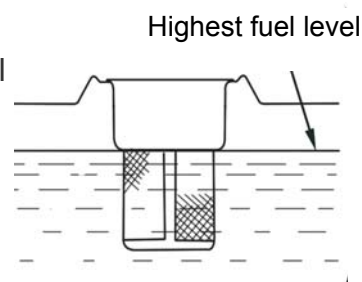

Preoperation check

Use unleaded gasoline with an octane rating of 90 or higher.

Unleaded gasoline produces fewer engine and spark plug deposits and extends exhaust system life.

NOTICE

Never use stale or contaminated gasoline or an oil/gasoline mixture. Avoid getting dirt or water in the fuel tank.

4) Air filter check

Remove the air filter cover and inspect the filter. Clean dirty filter elements. Always replace damaged filter elements.

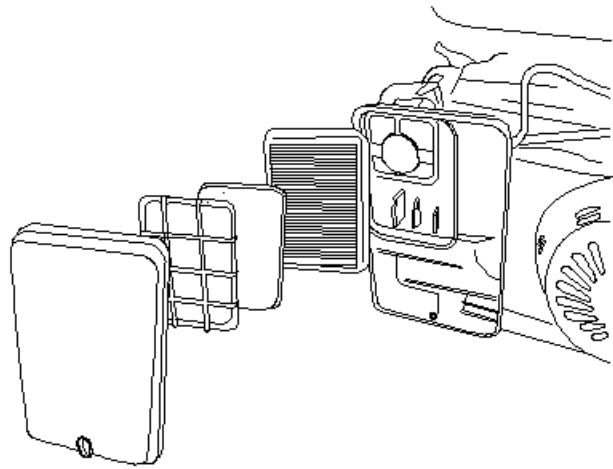

V. Operation and use of the set

1) Starting the engine

- ① Remove all loads from the output end.
- ② Open fuel switch
- ③ Put AC circuit breaker in the OFF position.
- ④ Put throttle lever in the OFF position.

NOTICE Do not shut off the choke if the engine is started when it is warm.

- ⑤ Put the engine switch in the ON position.
- ⑥ Gently pull up the starter grip and pull it out briskly when a resistance is felt.
- ⑦ When the engine has warmed up, put choke lever in the ON position.

2) Use of the generator

① Connecting to home power supply

NOTICE If the generator is to be connected to a home power supply as a standby, connection shall be performed by a professional electrician or by another person with proficient electrical skill.

When the loads are connected to the generator, please carefully check whether electrical connections are safe and reliable. Any improper connection may cause damage to the generator, or a fire.

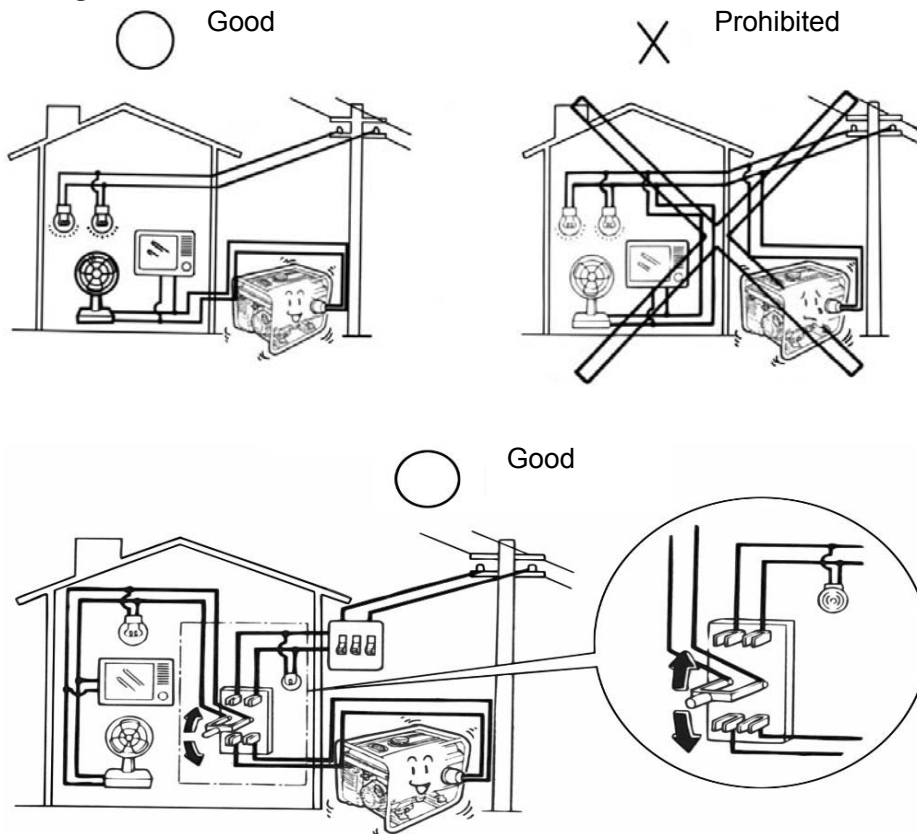

Operation and use of the set

② Before starting the generator, it should be confirmed that the total of all loads' power values doesn't exceed the generator's rated power.



NOTICE

Overload use will significantly shorten the generator's service life.

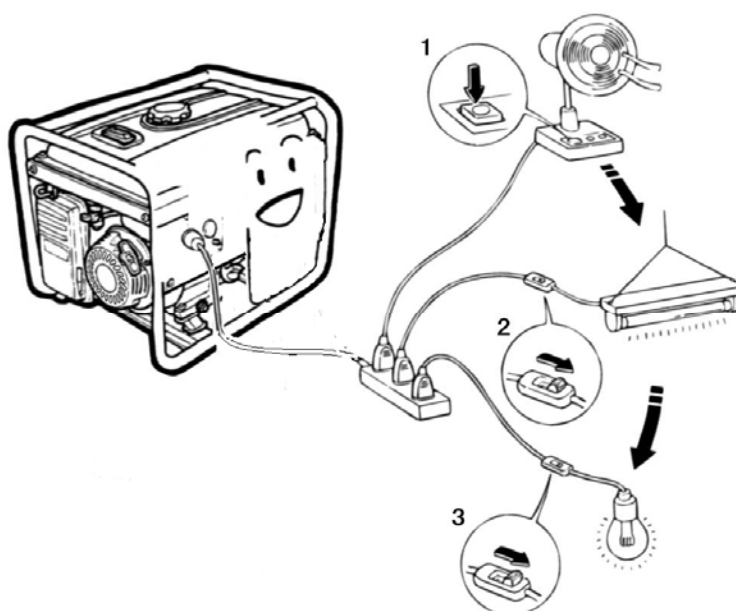
If the generator is to be connected to multiple loads or electricity consumers, please remember to first connect the one with the highest starting current, then the one with the second highest starting current... and last connect the one with the lowest starting current.

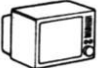

Generally, capacitive and inductive loads, especially motor driven devices will generate a very high starting current. The following table serves as a reference for your connecting the generator to the electricity consumers as shown in the table.

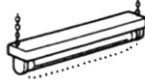
Type	Wattage		Typical device	Example		
	Starting	Rating		Device	Starting	Rating
<ul style="list-style-type: none"> ●Incandescent lamp ●Heating device 	X1	X1	 Incandescent lamp  TV set	 Incandescent lamp 100W	100VA (W)	100VA (W)
<ul style="list-style-type: none"> ●Fluorescent tube 	X2	X1.5	 Fluorescent tube	 Fluorescent tube 40W	80VA (W)	60VA (W)

Operation and use of the set

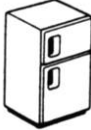
●Motor driven device	X3~5	X2	 Refrigerator Electric fan	 Refrigerator 150W	450~ 750VA (W)	300VA (W)
----------------------	------	----	---	--	----------------------	--------------

3) Use of welding power supply

①Description of welding chamber panel's functions

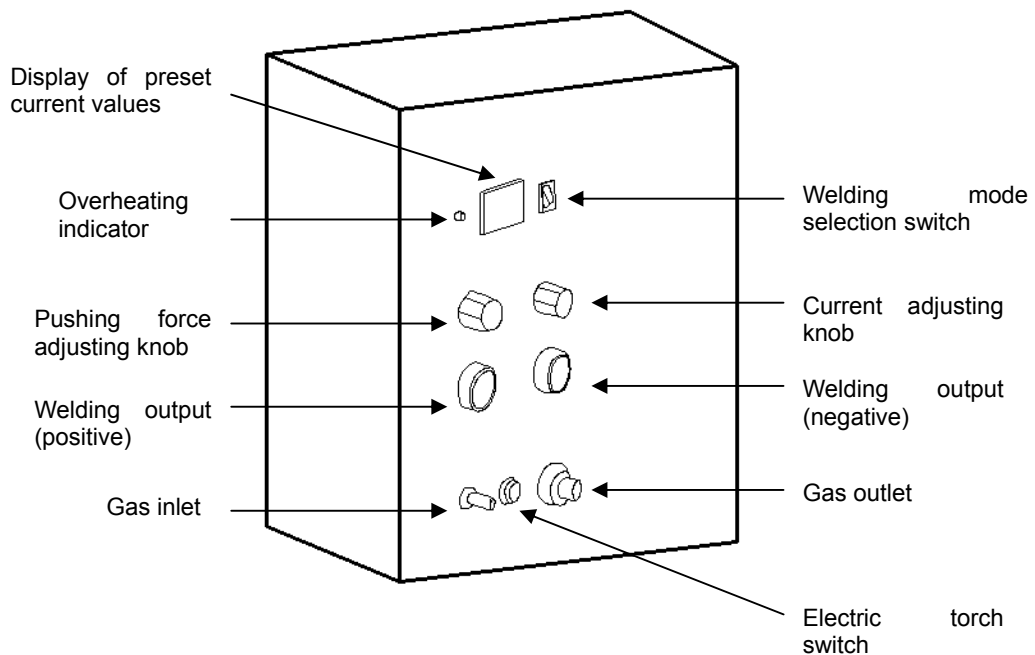

②Selection of welding mode and connection

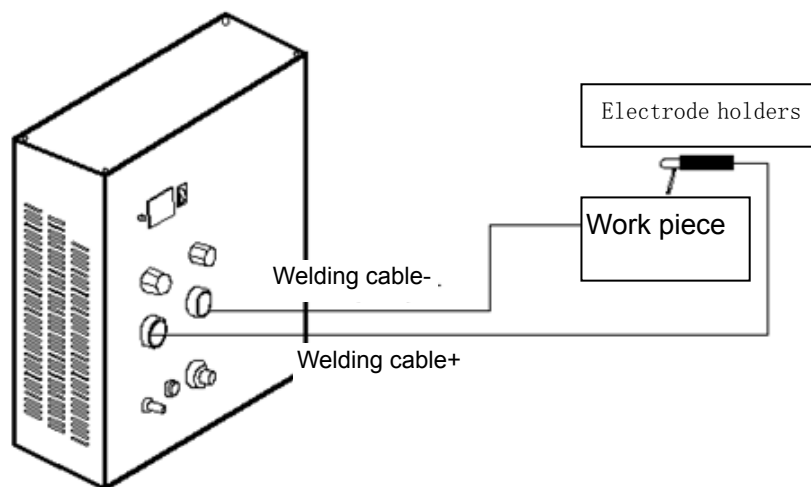

Connection of manual welding

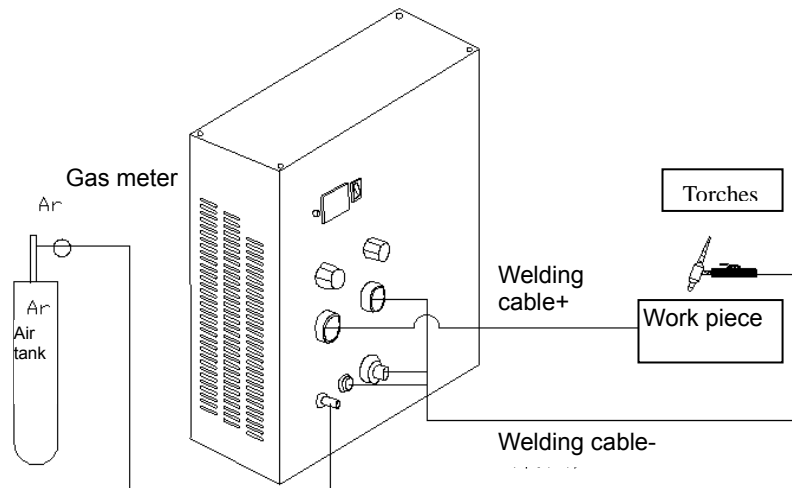

Connection of argon-arc welding

- ③ Turn on the power switch of welding power supply

NOTICE

Wait for about 2 to 3 minutes after turning on the power switch and the no-load voltage has been generated, then you may start welding operation.

- ④ Select the appropriate welding current as per needs of welding.
- ⑤ Weld
- ⑥ Turn off power switch of the welding power supply.

4) Stopping the engine

- ① Turn off the AC circuit breaker
- ② Turn off the engine switch
- ③ Turn off the fuel switch

NOTICE

If an emergency stop of the engine is needed, the engine switch shall be up in the OFF position.

VI. Maintenance of the set

Good maintenance is the best assurance for safe, economical and zero-malfunction running of the generator, and it is also good for environment protection.

⚠ WARNING Exhaust gas contains poisonous carbon monoxide. Maintenance can only be performed after the engine is stopped. If maintenance must be performed while the engine is running, the working area must be well ventilated.

Periodic maintenance and adjustment are necessary for keeping the generator in a good operating condition. Perform the service and inspection at the intervals shown in the Maintenance schedule below:

MAINTENANCE SCHEDULE		Each use	First month or 20 Hrs.	Every 3 months or 50 Hrs.	Every 6 months or 100 Hrs.	Every year or 300 Hrs.
Engine oil	Check oil level	○				
	Change		○		○	
Air filter	Check	○				
	Clean			○(1)		
	Replace					○*
Spark plug	Clean				○	Replace
Valve clearance	Check-Adjust					○(2)
Cylinder head	Clean	Every 300 Hrs. (2)				
Fuel tank and strainer	清洗 Clean	Every two years (2)				
Fuel line	更换 Replace	Every two years (2)				

- Maintain more frequently when the generator is used in dusty areas.
- These items should be maintained by an authorized dealer of Loncin.
- If the generator is to be used frequently, maintenance shall be performed as per the schedule above to ensure long-time normal operation.

⚠ WARNING Improper maintenance, or failure to correct a problem before operation, can cause a malfunction by which you can be hurt or killed. Always follow the recommended inspection and maintenance and schedules in this owner's manual.

1) Engine oil change

Drain the engine oil while the engine has been warmed to ensure complete and rapid draining.

- ① Remove the oil dipstick and screw off the drain plug to drain the engine oil
- ② Reinstall the oil drain plug and tighten it.
- ③ Refill with the recommended engine oil and check oil level.

Engine oil volume: 1.1 L

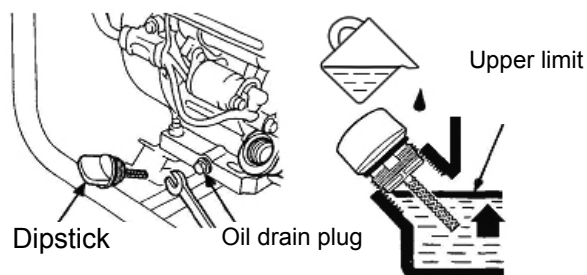

⚠ CAUTION Engine oil may cause skin cancer if repeatedly left in contact with the skin for prolonged periods. Although the skin cancer does not necessarily happen, it is still advisable to thoroughly wash the skin that has contacted engine oil with soap and water after handling engine oil.

For the sake of environment protection, please treat the used engine oil in an appropriate way. We strongly advise you to store the used engine oil in a sealed container and take it to the local service station or recycling center for reclamation. Never throw it in the trash or pour it on the ground or into the ditch.

2) Air filter maintenance

A dirty air filter will restrict air flow into the carburetor. To prevent carburetor malfunction, maintain the air filter regularly. Maintain it more frequently when operating the generator in extremely dusty areas.

⚠ WARNING Using gasoline or inflammable solvent to clean the filter element can cause a fire or explosion. Use only soapy water or nonflammable solvent.

NOTICE Never run the generator without the air filter, or rapid engine wear will result.

- ① Unsnap the air filter cover clips (or butterfly nut), remove the air filter cover and check the filter element to confirm it's complete and clean.
- ② Wash the element in a solution of household detergent and warm water, or in a

nonflammable detergent, or a high flash point detergent; squeeze the element to thoroughly remove the fluid in it.

If the paper element is dirty, gently knock it several times; then use compressed air (with a pressure not higher than 207KPa) to blow it from the inside to the outside. Never use a brush to clean the paper element, or the air pores of the element will be clogged.

- ③ If the element is damaged, replace it with a new one
- ④ Reinstall the air filter element and the cover

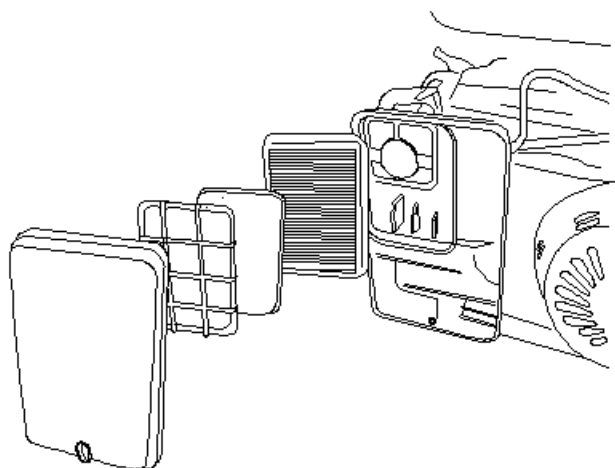

3) Clean the fuel sediment cup

- ① Turn the fuel valve to the OFF position, remove the fuel sediment cup, and take out the O ring and strainer.
- ② Clean the sediment cup, O-ring, and strainer in a nonflammable or high flash point solvent.
- ③ Reinstall O-ring and strainer, and the fuel sediment cup and tighten the cup.
- ④ Turn the fuel valve to the ON position and check for leaks

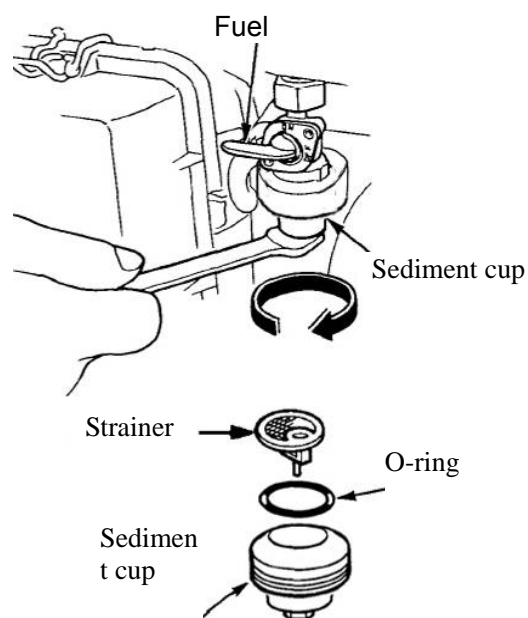

4) Spark plug check

Recommended spark plugs: F7RTC and F7TC

- ① Remove the spark plug cap.
- ② Clean any dirt from around the spark plug base.
- ③ Use the spark plug socket wrench to remove the spark plug.
- ④ Visually check whether the spark plug's insulation is damaged, replace it with a new one if its insulation is damaged.
- ⑤ Measure the plug gap with a feeler gauge. Correct as necessary by carefully bending the side electrode. The gap should be: 0.70-0.80 mm (0.028-0.031 in).

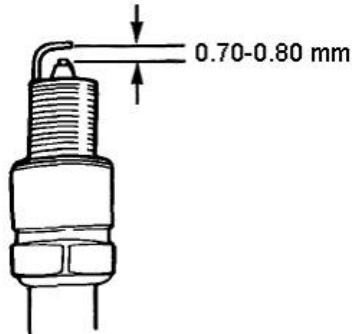
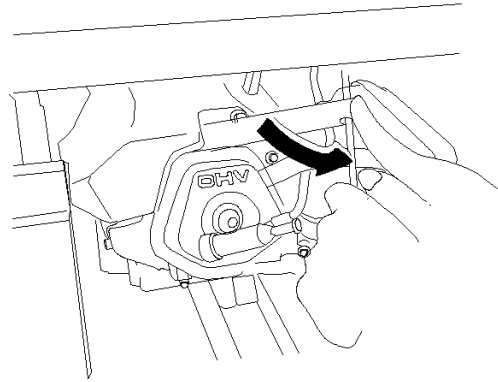

- ⑥ Check whether the spark plug washer is in a good condition
- ⑦ Reinstall the spark plug and use the spark plug socket wrench to tighten it and tightly press the spark plug washer; then reinstall the spark plug cap.

NOTICE

Use the spark plug of the appropriate heat range.

VII. Storage

⚠ WARNING Contact with a hot engine part can cause a fire. Let the engine cool before transporting or storing the generator.

If the generator is to be stored for a long period, the storage area must be kept clean and dry.

- 1) Drain the fuel of the fuel tank completely. Clean the fuel strainer, O-ring and sediment cup; then reinstall them. Loosen off the drain plug of the carburetor and drain off the fuel in it; then reinstall carburetor drain plug and tighten it.

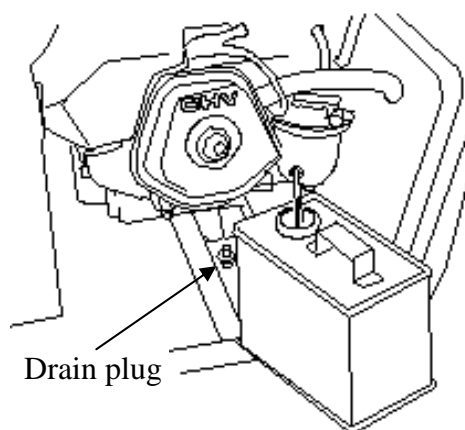

⚠ WARNING Gasoline is extremely inflammable and is explosive under most conditions. Perform this task in a well ventilated area with the engine stopped. Never smoke or allow flames or sparks in the area during this procedure.

- 2) Screw off the engine oil dipstick, and screw off the drain plug of the crankcase to completely drain off the engine oil of the crankcase.
Screw in the drain plug and tighten it, and add new engine oil until oil level reaches the upper limit, then reinstall the engine oil dipstick.
- 3) Remove the spark plug and add a spoon of clean engine oil into the combustion chamber. Crank the engine several revolutions to distribute the oil; then reinstall the spark plug.
- 4) Gently pull the starter grip until a resistance is felt, keep all the inlet valves and outlet valves closed.
- 5) Put the generator in a clean and dry area.

VIII. Troubleshooting

1) Engine doesn't start

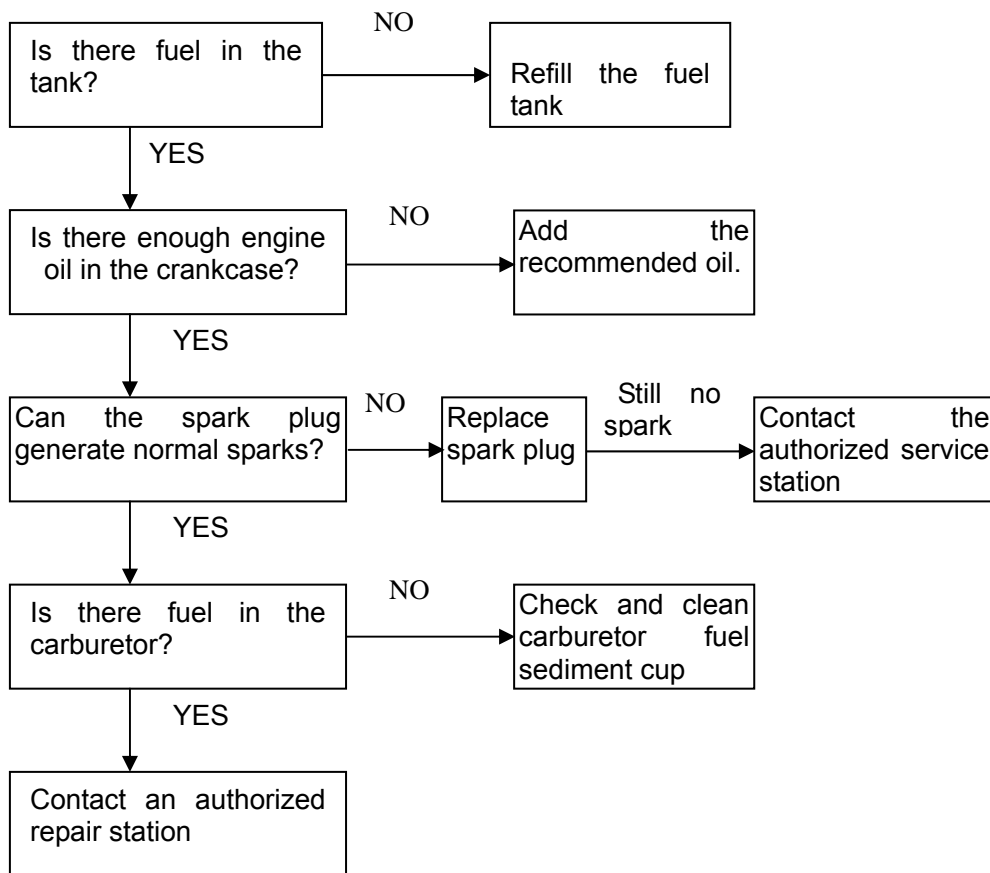

2) No output voltage:

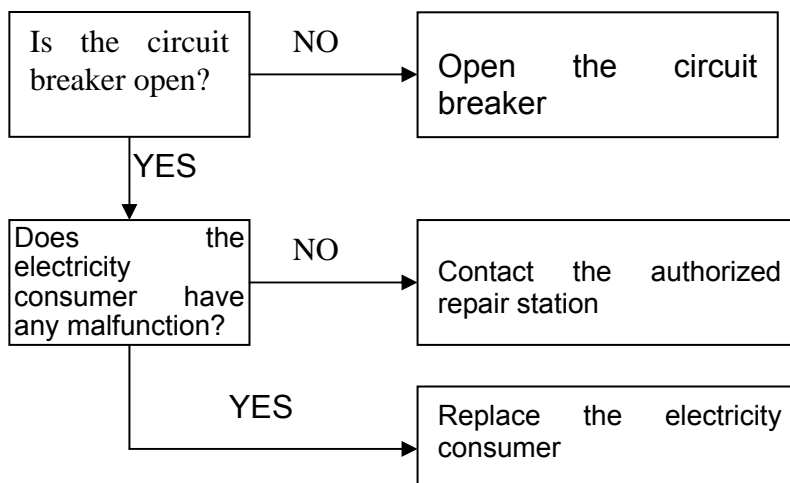

3) Solving common problems of welding power supply

⚠ WARNING Only the persons with relevant qualifications can open the welding power supply to inspect, maintain and repair it.

S/ N	Phenomenon	Possible cause	Correction
1	Any trouble	<ul style="list-style-type: none"> ○ Incorrect operation ○ Loose connector of the circuit board ○ Visually observed damage or severance of any line ○ Damaged part determined by professional knowledge ○ Damaged circuit board 	<ul style="list-style-type: none"> ○ Operate as per the manual ○ Restore good connection ○ Connect the line ○ Replace it ○ Contact the manufacturer
2	Voltage meter doesn't light after turning on power supply	<ul style="list-style-type: none"> ○ Power switch is damaged ○ Industrial frequency transformer is damaged ○ Digital display is damaged 	<ul style="list-style-type: none"> ○ Replace power switch ○ Replace this transformer ○ Replace it with a new one
3	Voltage meter lights after turning on power switch but manual welding cannot be conducted	<ul style="list-style-type: none"> ○ Select argon-arc welding using function selection switch ○ The inverter is damaged ○ The circuit board is damaged 	<ul style="list-style-type: none"> ○ Select manual welding using function selection switch ○ Replace it with a new one ○ Replace it
4	Overheating indicator lights during welding, and welding machine doesn't work	<ul style="list-style-type: none"> ○ Environment temperature is too high, or ventilation is not good ○ Long overload on the welding machine results in overheating protection of welding machine 	<ul style="list-style-type: none"> ○ Improve ventilation and cooling conditions ○ Cool it to let restore functions automatically
5	Automatic cutoff of power by power switch	<ul style="list-style-type: none"> ○ The inverter is damaged ○ The circuit board is damaged 	<ul style="list-style-type: none"> ○ Replace it ○ Replace it

NOTICE

Please timely inform our company's technical service department of the fault's features if you cannot solve the problem by yourself, our company will timely deal with such a problem.

Technical parameters

IX. Technical parameters

1) Main technical parameters (take WG6500MP-1 in the following table for example)

Welding power supply	Welding mode	Manual welding		DC argon-arc welding		Pulse argon-arc welding	
	No-load voltage (V)	75		75		75	
	Current adjusting range (A)	20~150		15~200		15~200	
	Pulse frequency (Hz)					30	
	Welding current (A)	150	116	200	155	200	155
	Welding voltage (V)	26	24.6	18	16.2	18	16.2
	Load duration factor	60%	100%	60%	100%	60%	100%
Generator	Rated output power (KW)	5					
	Maximum output power (KW)	5.5					
	Rated output voltage (VAC)	230					
	Rate output current (A)	21.7					
	Frequency (Hz)	50					
	Power factor	1.0					
Whole set	Cooling method	Forced air cooling					
	Weight(net) (Kg) /size (mm)	WG6500M-1			90/725×583×562		
		WG6500MT-1			100/725×583×562		
		WG6500MP-1			100/725×583×562		
Protection/insulation grade	IP21/F						

2) External (static) characteristic of welding power supply (see figure below)

Figure2 External (static) characteristic

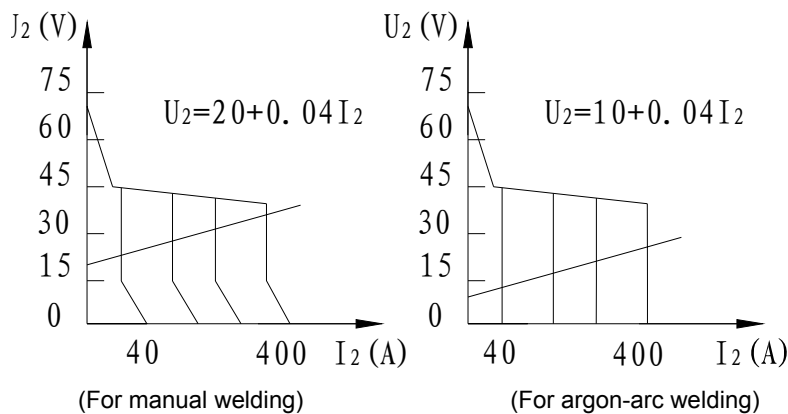

X. Schematic diagram

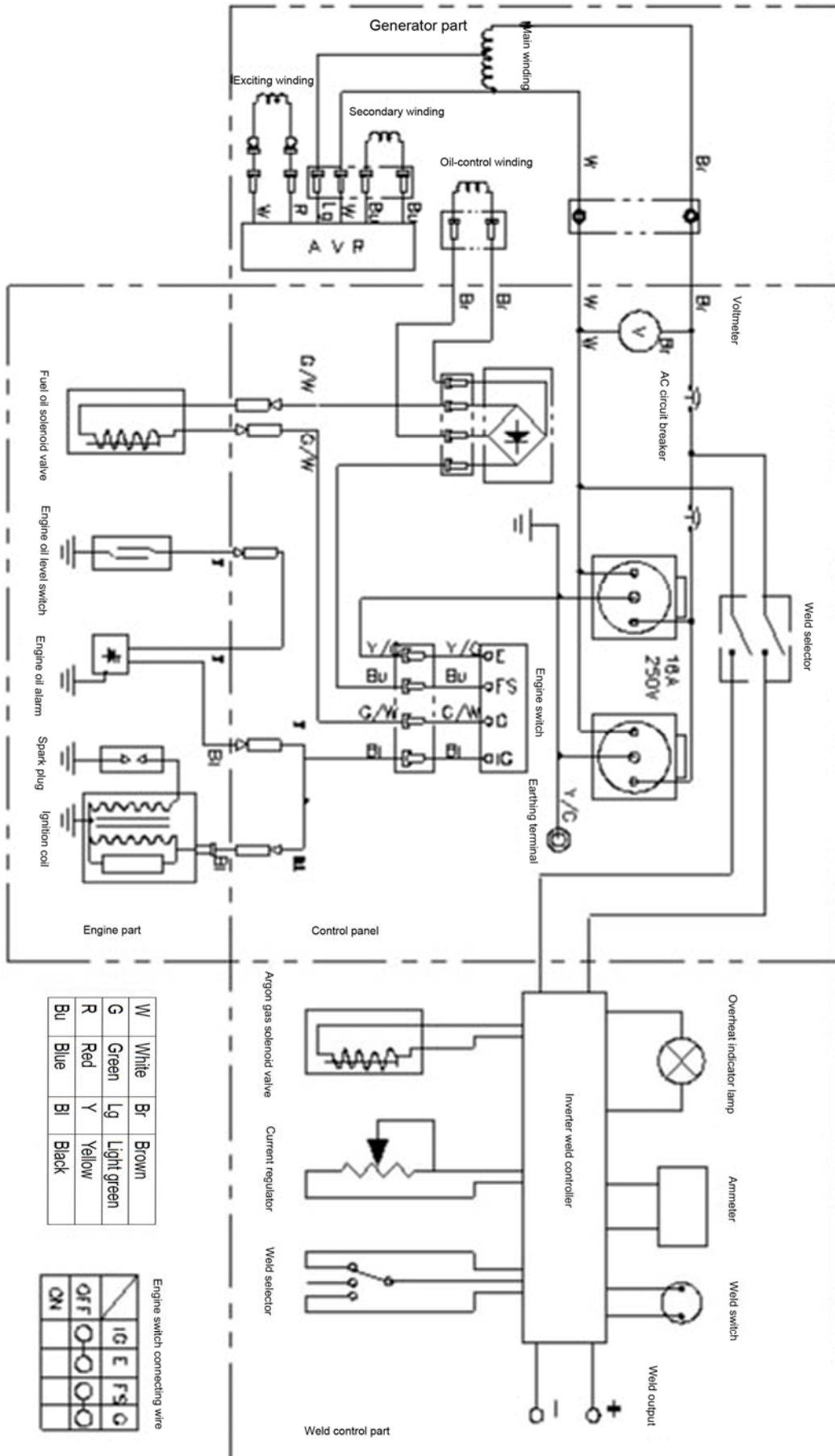

Wheel and handle Set(In Optional)

XI. Wheel and handle Set(In Optional)

- 1) Assemble the 2 wheels on the axle with washer and lock nut.
- 2) Install the wheel kits on the frame mounting board with bolts and nuts.
- 3) Install the handle kit with bolts and nuts, then mount on the frame.
- 4) Assemble the vibration isolators with bolts and nuts, then mount on the frame mounting board.

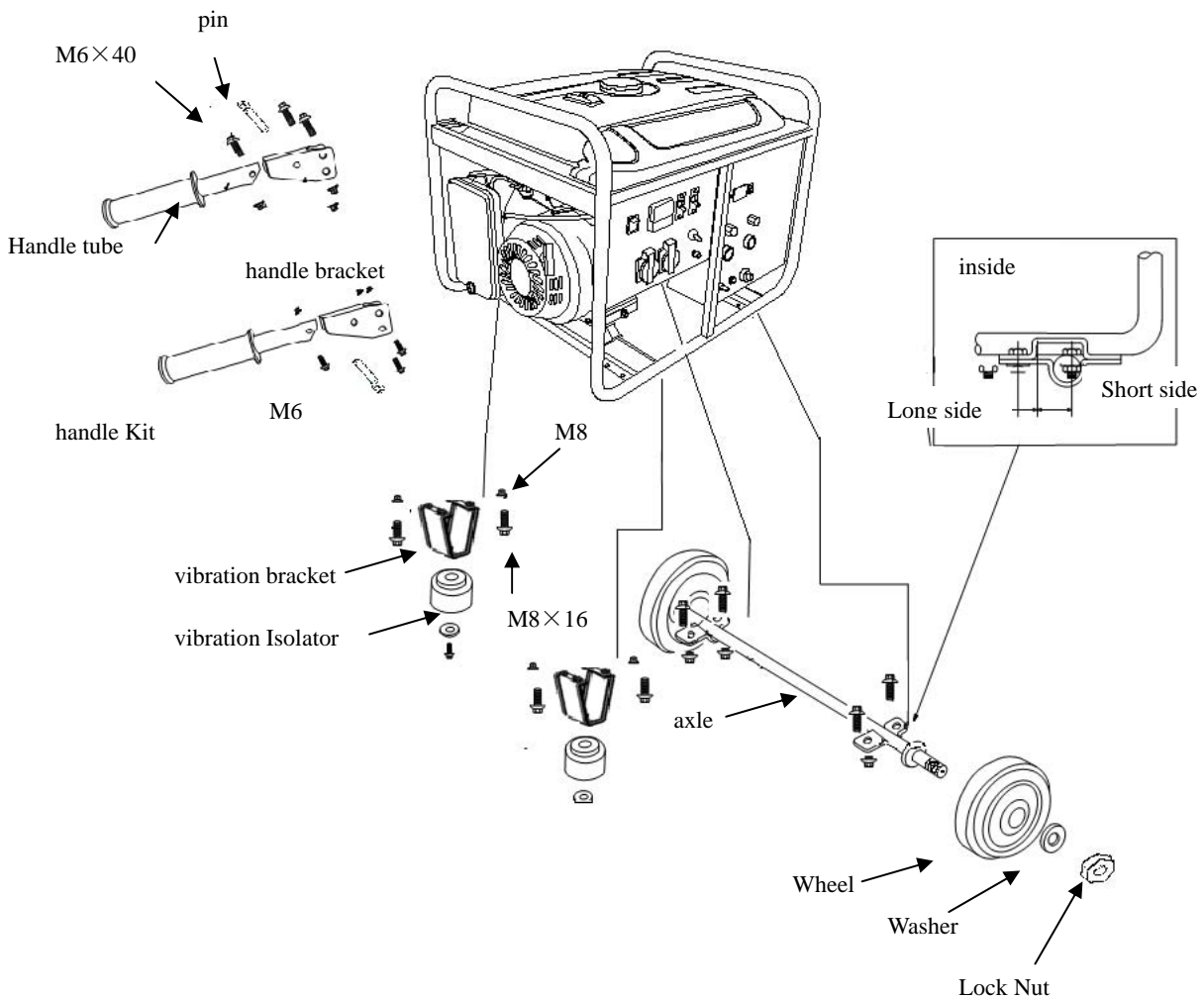



Loncin motor co., Ltd.

Add: No. 99 Hualong Road, Jiulongpo District, Chongqing, China

Tel: 86 23 8980 5678 / 86 23 8980 8505

Fax: 86 23 8906 7566

Email: marketing@loncinengine.com

Website: www.loncinengine.com

PRINTED IN CHINA